

# Traction Inverter Module

**TIM300**  
**TIM400**  
**TIM600**

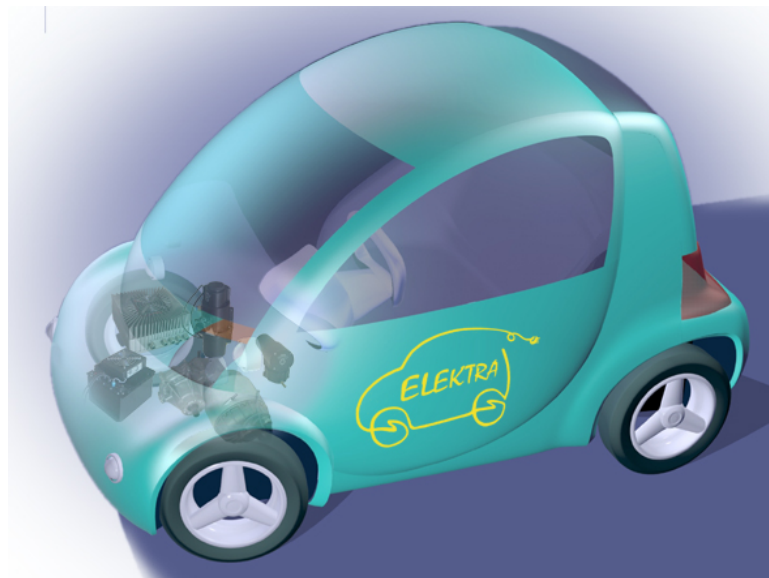

## User Manual

Installation guide of Electric Powertrain MES-DEA

**Version:** Draft 7.2 ENG

**Hardware:** TIM300 30X57138.00  
TIM400 30X57134.00  
TIM600 30X57132.00

**Firmware:** 23.0

**Data:** 20/10/2008

**Author:** Uilli Cassani



<b>INDEX</b>	<b>Page</b>
<b>1. SAFETY INFORMATION</b> .....	<b>05</b>
<b>2. INTRODUCTION</b>	
2.1 Overview.....	06
2.2 Electric Vehicles Layout .....	07
2.3 .....	08
<b>3. INSTALLATION</b>	
3.1 Mechanics Installation.....	09
3.2 Cooling system Wiring.....	10
3.3 Main connector X1 ( 42 Poli ).....	11
3.3.1 Scheme connection X1.....	12
3.3.2 Signal Table X1.....	13
3.3.3 Low Voltage Power supply connection.....	14
3.3.4 Key Signal Connection .....	14
3.3.5 Logic Input .....	15
3.3.5.1 Traction Enable Connection.....	15
3.3.5.2 Regenerative Enable Connection.....	15
3.3.5.3 Brake Signal Connection.....	16
3.3.5.4 Hand Brake Signal Connection.....	16
3.3.5.5 Emergency Signal Connection.....	16
3.3.5.6 Nets signal Connection (Charger).....	16
3.3.5.7 Selector Gear Connection.....	16
3.3.6 Analog Input.....	17
3.3.6.1 Throttle signal.....	17
3.3.6.2 Power Limitation.....	17
3.3.6.3 Regenerative Limitation.....	18
3.3.7 Input PWM Power Limitation.....	18
3.3.8 Logic Output .....	19
3.3.8.1 Inverter ready.....	19
3.3.8.2 Speed below P50.....	19
3.3.8.3 Cooling Fan enable.....	19
3.3.8.4 Power steering Renault .....	19
3.3.8.5 Reverse Light enable.....	20
3.3.8.6 Stop Light enable.....	20
3.3.9 Tachometer Output.....	20
3.3.10 Serial Communication.....	20



3.3.11	<i>CAN-BUS Communication</i> .....	20
3.3.12	<i>Power Output</i> .....	21
3.3.12.1	<i>Parking Enable</i> .....	21
3.3.12.2	<i>Parking Disable</i> .....	21
3.4	<b>Motor Connection</b> .....	22
3.4.1	<i>Motor Phase Connection</i> .....	23
3.4.2	<i>Motor Signal Connection X3 (8contact)</i> .....	24
3.4.2.1	<i>Scheme Connections X3</i> .....	25
3.4.2.2	<i>Signal Table X3</i> .....	25
3.5	<b>Traction Battery Connection</b> .....	26
4.	<b>SOFTWARE SUPERVISOR RS-232</b>	
4.1	<b>Installation</b> .....	27
4.2	<b>Main Windows (INTRO)</b> .....	29
4.2.1	<i>I/O</i> .....	30
4.2.2	<i>Parameters</i> .....	31
4.2.3	<i>Connections</i> .....	32
4.2.4	<i>Alarms</i> .....	33
4.2.5	<i>Display</i> .....	34
4.2.6	<i>Utility</i> .....	35
4.2.7	<i>Monitor</i> .....	36
4.2.8	<i>Graphic</i> .....	37
4.2.9	<i>Diagram</i> .....	38
4.2.10	<i>Save</i> .....	39
5.	<b>INVERTER SETUP</b>	
5.1	<b>Insert Battery data</b> .....	40
5.2	<b>Throttle calibration</b> .....	40
5.3	<b>Insert Motor data</b> .....	41
5.4	<b>Procedure for Motor calibration</b> .....	42
5.4.1	<i>Test Connection and Number Poles</i> .....	42
5.4.2	<i>Auto-Tuning</i> .....	43
5.5	<b>Gear Setup</b> .....	44
5.6	<b>Regenerative Brake setup</b> .....	45
5.7	<b>Tachometer setup</b> .....	45
5.8	<b>Setup CAN-BUS</b> .....	46
5.8.1	<i>Rx Message</i> .....	47
5.8.2	<i>Tx Message</i> .....	48



<b>6.</b>	<b>UPDATE FIRMWARE</b>	
6.1	Procedure Update Firmware Dsp.....	50
6.2	Procedure Update Firmware Pld.....	51
<b>7.</b>	<b>SIMPLE TROUBLESHOOTING</b>	
7.1	Alarms List.....	53
7.2	Discover and solution fault.....	53
7.3	Defective handling instruction.....	53
<b>8.</b>	<b>TECNICAL FEATURE</b>	
8.1	Data-sheet.....	54
8.2	Dimension.....	55
8.3	Certifications.....	56
8.4	Warranty.....	57

**APPENDIX**

Circumference Tyre Table.....	58
Parameter Table.....	60
Connection Table.....	66
Table of Measure available .....	69
Logic Input Table.....	70
Logic Output Table.....	70
Table of Analogic Measure available .....	71



## 1. SAFETY INFORMATION

Before install and use the product read these handbook carefully, this must be available at all people that are had deal with the installation and setting of the powertrain.

Installation, cable and cover opening of the device shall be made without voltage.

Any operation inside the device should be made without voltage. Because of capacitors, please verify with a tester before operating inside the device.

All responsibility will be forgone if the apparatus is used inappropriately or in a different way than is advised in the manual.

Any modification or operation that is not included in the manual is not permitted without the manufacturer's authorisation and must be carried out by qualified personnel.

The proper working and life of the device are dependant on the maitenance of the ambient temperature within the allowed ranges of values.

Switch off the system before open the cover, and check with multimeter the absence of voltage.

Please attention electronic components sensible at electrostatic discharge ESD present inside, to use all one's cunning for avoid damage.

The use of this device can be dangerous because make turn the motor and relative connection and inside the system there are high voltage.

The device and the manual are subject to change without notice.

MES-DEA disclaim all responsibility for every improper use of this device different that write in this manual.

### **WARNING !!!**

**Before activation for the first time, it is advised to lift the vehicle off the ground, as a wrong connection of the accelerator or an incorrect software configuration may start the vehicle.**



## 2. INTRODUCTION

### 2.1 Overview

The TIM series MES-DEA inverter are designed with the purpose to manage a wide range of asynchronous motors for electric traction vehicles. Their objective is to convert direct current drawn from the battery into three phase alternative current suitable to supply the induction motor and can be used in a wide range of electric vehicles, including light four wheelers, city-cars, van and buses of small and medium size.

The inverter communication systems work by serial RS 232 and CAN-BUS. This one is optimized to communicate with ZEBRA batteries, but other protocols can be implemented as optional.

With the practical supervision software is possible to monitor various variables of the traction system and to custom the device parameters in order to obtain a formula. In case of production of fleets of vehicles, the formula can be saved on the PC and then loaded on the other inverters in order to simplify the setting up of the vehicles.

Various protection can be set, such as minimum and maximum input voltage on the DC bus, maximum DC current supplied during traction and regenerative braking, max current and max phase voltage of the AC motor, max speed, acceleration and deceleration ramp, etc.

The inverter manages the traction directly from the received signals and the torque supplied by the motor is directly proportional at the throttle signal.

A correct setup of the regenerative braking allows to recreate a pleasant motor braking feeling, present on the internal combustion engine powered vehicles, but with the advantage to restore energy during decelerations and down hills and, at the same time, to decrease the wear and tear of the braking system.

The algorithm of control of the motor is vectorial type with indirect torque control and direct speed control in closed loop.



## 2.2 Electric vehicles layout

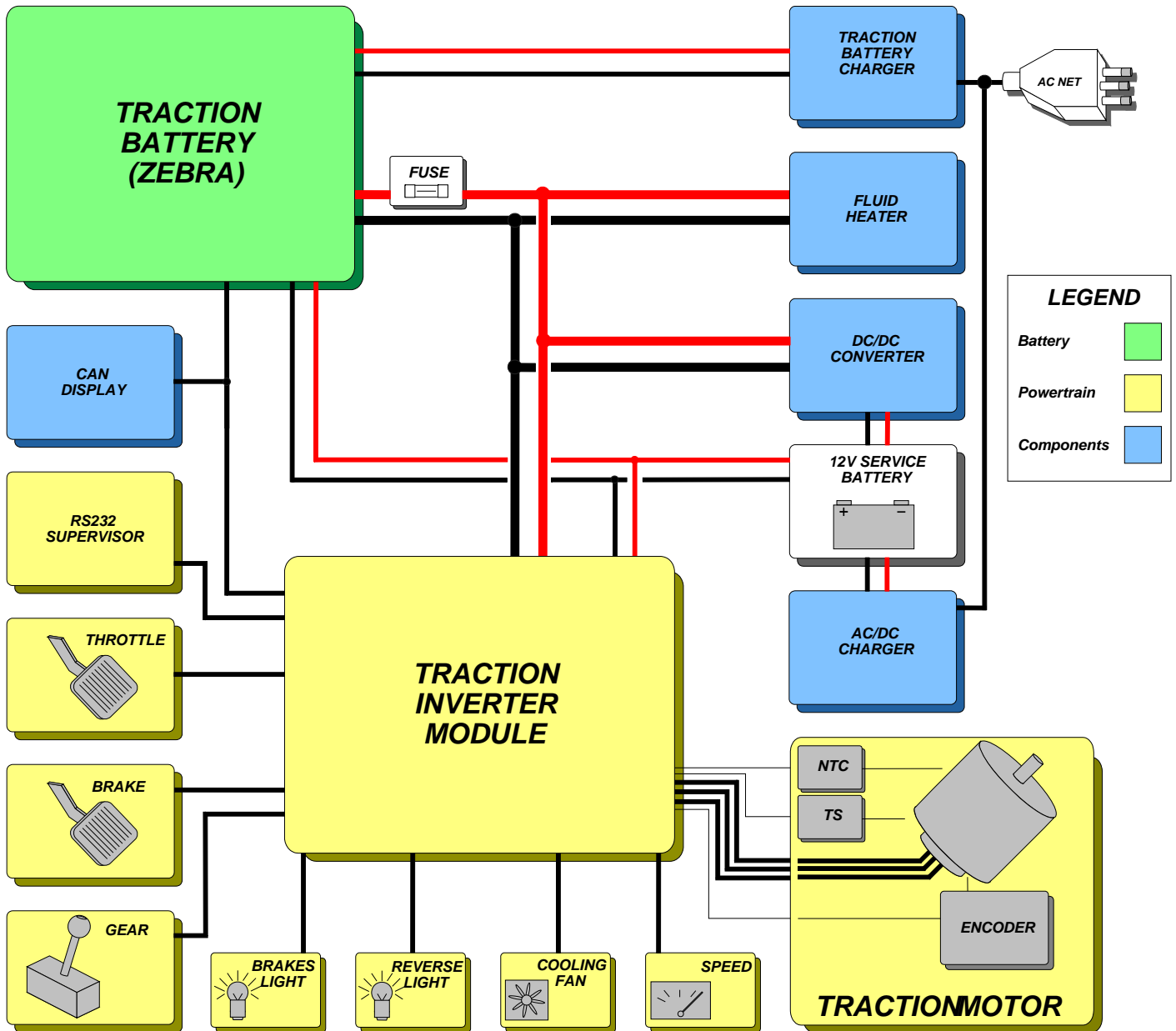

( Photo 1 )

The previous scheme shows, in a simplified way, the components of a vehicle with electric traction and the most important signals that have to be managed.

The MES-DEA inverters can be used with every type battery, with the condition that voltage levels are compatible. All that quantities linked to the traction are directly controlled and the system interprets and manages them for the best.



## 2.3 Check List





### 3. INSTALLATION

The inverter set up is shared in three phases: mechanic, hydraulic and electric.

During the electric set up please be sure to avoid that metallic waste, coming from unhearing and crimping of wires, drop inside the device.

Particular attention must be paid to prevent electro static discharge (ESD protection) that could damage the inverter.

#### 3.1 Mechanics installation

The device can be mounted in every position: MES-DEA suggests to mount the inverter in horizontal position, placed above the motor, keeping connections short t avoid to catch inconveniences, specially on encoder signals. The suggested position permits an easier access at the cover for inspections and upgrades. Furthermore, this position is the safer in case of losses from the cooling system because glycol drops cannot fall on the electronic boards on or electric contacts, but are bound on the dissipater bottom. Because of the importance of the traction device, and due to safety reasons in case of crash, we **don' t advise** to place it at shot distance from the ground, especially when protections are missing.



( Photo 2 )



### 3.2 Cooling system comments

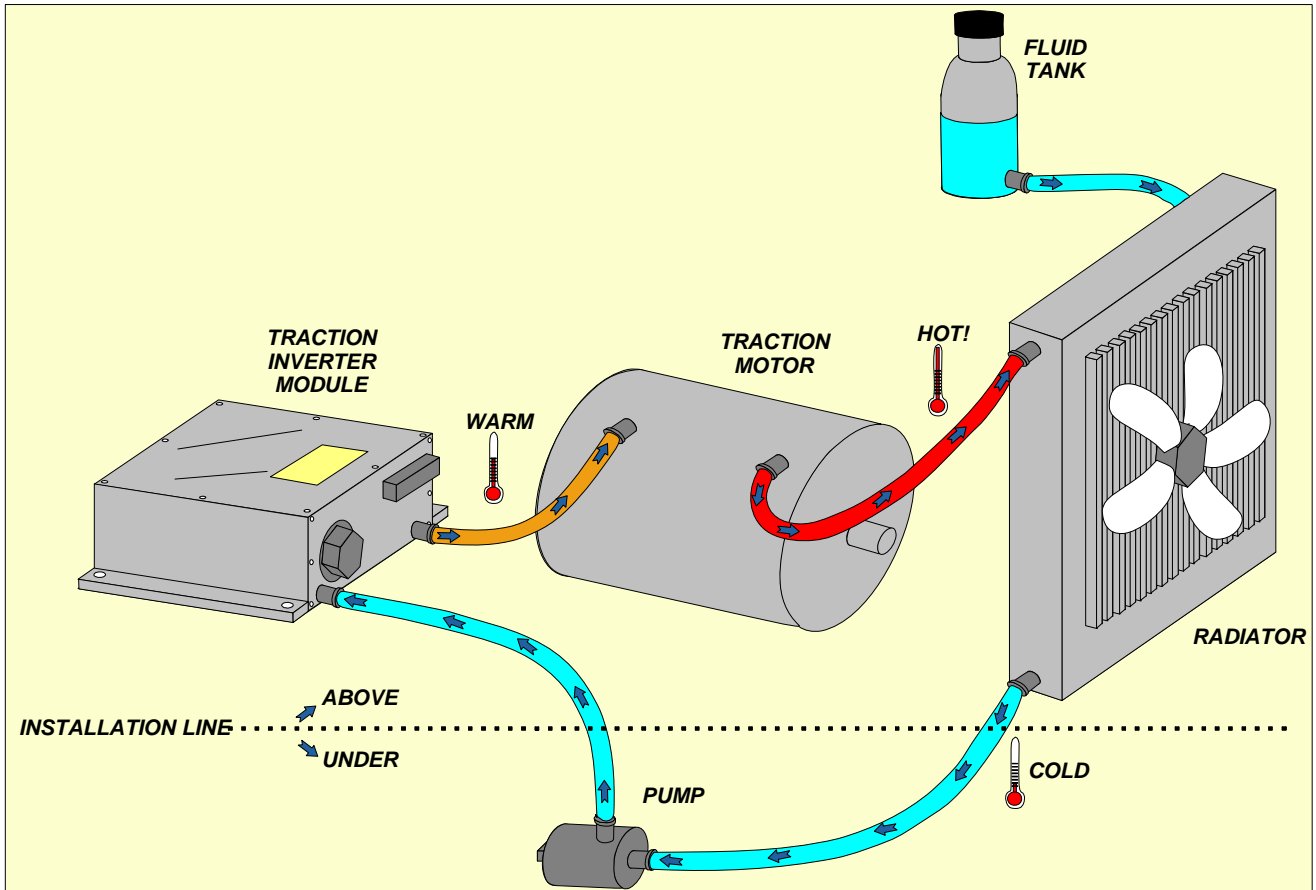

( Photo 3 )

The inverter thermal dissipation is granted by a liquid cooling system (see Fig. 2). Due to the fact that the working temperature of the inverter is very lower than the motor's, it is important to connect the inverter just after the circulation pump and before the motor in the cooling circuit, in order to avoid over-temperatures. It is **recommended** to place the circulation pump at the lower point of the cooling circuit, in order to simplify the flow out of the air from the system and thus to limit cavitations possibilities with breaking of the pump.

A too long cooling circuit, or a not adequate section, can leads to pressure losses increasing and, consequently, to a flow rate decreasing of the pump, with possible overheating of the traction system. It is suggested, where possible, to measure the pressure losses of the cooling system in order to verify that the real pump working point will grant the requested minimum flow rate. The inverter is able to read its own temperature and the temperature of the MES-DEA motor windings and to activate protection and limitation if necessary.

The regular working and the life of inverter and motor are affected by the working temperature: we strongly suggest to keep it between the allowed values.



### 3.3 Main Connector X1 ( 42 Contants )

This is the main connector of the Inverter where the back-up power suppli and all the signals with destination or origin are wired: Gear, Accelerator, Ratchet gear, Battery Management, Speedometer, RS-232, CAN-BUS. On the back side of the connector is possibile see the number of the pin connected, see (photo 6 ).

( Photo 4 )



( Photo 5 )



With the Inverter it supply the connection kit **Mes-Dea cod. 30x57304.00** consisting of:

- |   |             |  |
|---|-------------|--|
| 1 Connector body User side                            |             | ( AMP C967281-1 Mes-Dea cod. 21x36714.00 ) |
| 1 Rear cover for the cable                            |             | ( AMP C965643-1 Mes-Dea cod. 21x36717.00 ) |
| 6 Junior Power type faston ( 0.5-1.5mm <sup>2</sup> ) |             | ( AMP C927770-1 Mes-Dea cod. 21x36737.00 ) |
| 36 Micro Timer type faston ( 0.5-1.0mm <sup>2</sup> ) |             | ( AMP C962942-1 Mes-Dea cod. 21x36718.00 ) |
| Gaskets x Junior Power faston                         | <b>Opt.</b> | ( AMP C828905-1 Mes-Dea cod. 21x36738.00 ) |
| Gaskets x Faston Micro Timer                          | <b>Opt.</b> | ( AMP C963530-1 Mes-Dea cod. 21x36719.00 ) |

( Photo 6 )



( Photo 7 )



3.3.1 Scheme connection X1

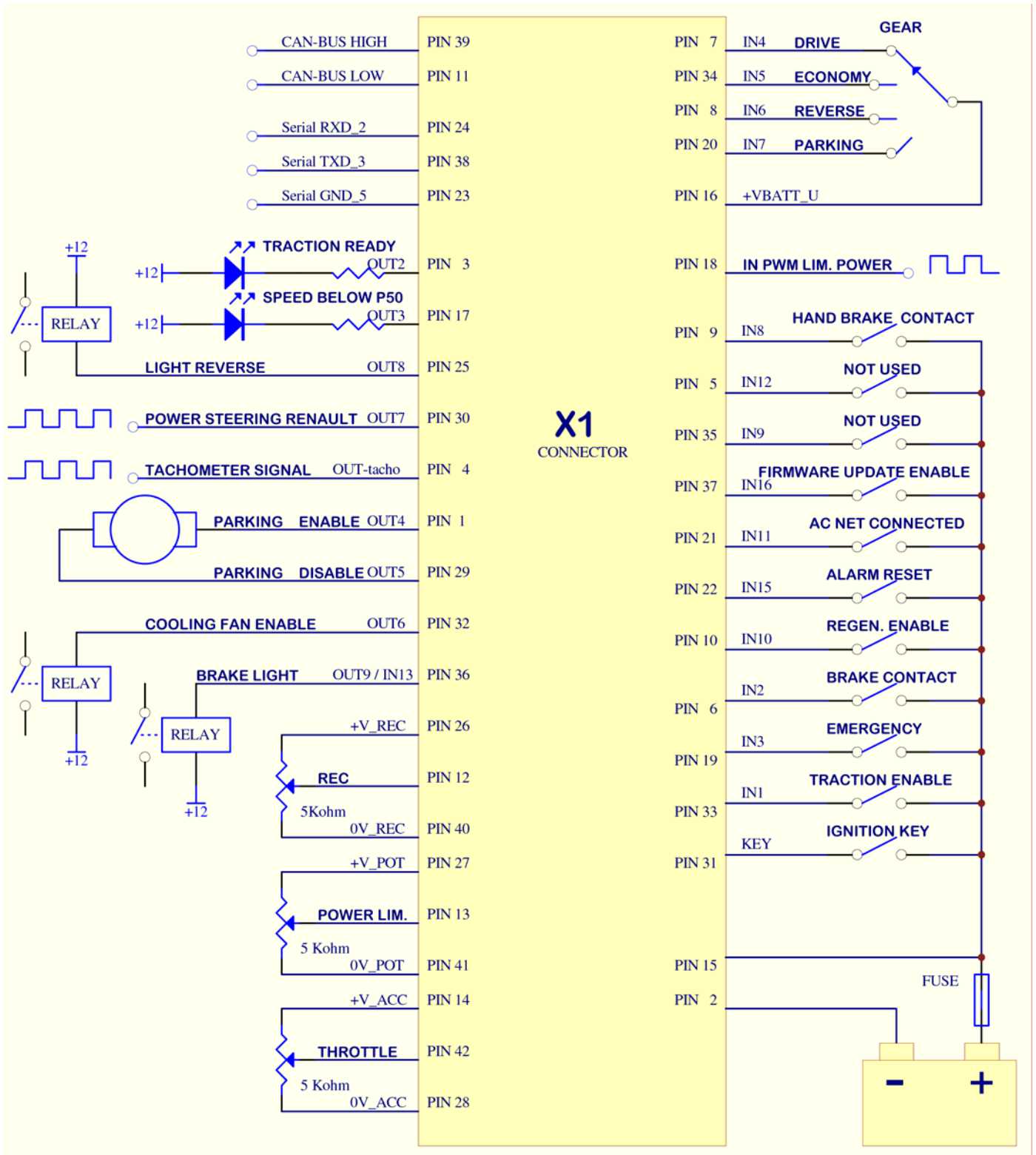

(Photo 8)



### 3.3.2 Signal Table X1

PIN	Description	Function	Connection
1	Out4	Output Ratchet gear enabled (parking mode)	Optional
2	0Volt	Ground service battery	<b>Request</b>
3	Out2	Output Inverter ready	Optional
4	Out-tacho	Output Speedometer ( frequency )	Optional
5	In12	Not used	Optional
6	In2	Signal that brake is pressed (Luci stop)	Optional
7	In4	Change to "Drive mode" position	<b>Request</b>
8	In6	Change to "Reverse mode" position	<b>Request</b>
9	In8	Hand Brake signal	Optional
10	In10	Regenerative enable	<b>Request</b>
11	CAN LOW	CAN-BUS	Optional
12	X1_REC	Regenerative Limitation Cursor Reference	Optional
13	X1_Rid_Pot	Reduction Power Cursor Reference	Optional
14	+V_ACC	5Volt power supply for Accelerator	<b>Request</b>
15	+12Volt	Positive Supply service Battery	<b>Request</b>
16	+VBATT_U	Output signal power supply	<b>Request</b>
17	Out3	Output speed of vehicle below to (P50)	Optional
18	PWM_Rid_Pot	Input reduction power (PWM)	Optional
19	In3	Emergency	Optional
20	In7	Change to "Parking mode" position	Optional
21	In11	Battery charging	Optional
22	In15	Alarm reset	Optional
23	DG	Serial RS232_GND_5	Optional
24	RXD232	Serial RS232_RXD_2	Optional
25	Out8	Output enable reverse light	Optional
26	+V_REC	5Volt power supply for Regenerative Limitation	Optional
27	+V_Rid_Pot	5Volt power supply for Reduction Power	Optional
28	-0V_ACC	0Volt power supply for Accelerator	<b>Request</b>
29	Out5	Output Ratchet gear disabled (parking mode)	Optional
30	Out7	Output power steering	Optional
31	+V_Key	Input Key enable	<b>Request</b>
32	Out6	Output enable radiator fan	Optional
33	In1	Input traction enable	<b>Request</b>
34	In5	Change to "Economy mode" position	Optional
35	In9	Not used	Optional
36	In13/Out9	Output enable brake light	Optional
37	In16	Firmware Update Enable	Optional
38	TXD232	Serial RS232_TXD_3	Optional
39	CAN HIGH	CAN-BUS	Optional
40	-0V_REC	0Volt power supply for Regenerative Limitation	Optional
41	-0V_Rid_Pot	0Volt power supply for Reduction Power	Optional
42	X1_ACC	Accelerator Cursor Reference	<b>Request</b>



### 3.3.3 Low Voltage Power Supply connection

+12Volts DC must be supply to device ( available also 24Volts version)

Pin 15	<b>+12 Volt</b>	Positive Service Battery ( direct – not below the key )
Pin 2	<b>0 Volt</b>	Negative Service Battery

Normal consumption with key signal present is about 700mA, this can grow until 5 Amps when you enable and disable the parking system.

The consumption of Inverter without signal key after a fix time (Default setup P111=4 sec.) equal to 0mA

Advice Fuse (10 Amps )

### 3.3.4 Key signal Connection

The key signal is required to switch on the Inverter

Pin 31	<b>+V_Key</b>	Key Signal ( +12V active )
--------	---------------	----------------------------

Normal consumption at the start up with key signal activation is about 700mA.



### 3.3.5 Logic input

The input became active with high level, while are disactive at low level.

High Level ( H ) or level 1 : Voltage between 9 and 12 V consumption about 10 mA.

Low Level ( L ) or level 0 : Voltage between 0 and 6V consumption below of 10 µA.

Pin	Input	Description signal
33	In1	Traction enable
06	In2	Brake signal
19	In3	Emergency
07	In4	Gear position “ Drive mode “
34	In5	Gear position “ Economy mode “
08	In6	Gear position “ Reverse mode “
20	In7	Gear position “ Parking mode “
09	In8	Hand Brake signal
35	In9	Not used
10	In10	Regenerative enable
21	In11	Battery on charge
05	In12	Not used
36	In13	Not used
22	In15	Alarms Reset
37	In16	Enable Firmware update

#### 3.3.5.1 Traction Enable Connection

The traction enable signal is required for put in traction the motor, without this the motor can't start.

Pin 33                      In1                      Traction enable ( +12V active )

#### 3.3.5.2 Regenerative Enable Connection

The Regenerative enable signal is required to insert regenerative function when the throttle is set free or when you push the brake pedal.

Pin 10                      In10                      Regen enable ( +12V active )



### 3.3.5.3 Brake signal Connection

When Brake signal is present the throttle is ignore and the motor increase the regenerative work.

Pin 6	<b>In2</b>	Brake Signal ( +12V active )
-------	------------	------------------------------

### 3.3.5.4 Hand Brake signal Connection

The Hand Brake signal don't change nothing is only a notice.

Pin 9	<b>In8</b>	Brake Signal ( +12V active )
-------	------------	------------------------------

### 3.3.5.5 Emergency Signal Connection

This signal disable all the power output of the inverter

Pin 19	<b>In3</b>	Emergency Signal ( +12V active )
--------	------------	----------------------------------

### 3.3.5.6 Nets Signal Connection (Charger)

When this signal is present the motor can't start.

Pin 21	<b>In11</b>	Net Signal ( +12V active )
--------	-------------	----------------------------

### 3.3.5.7 Selector Gear Connection

The Inverter can manage 4 state of gear:

Pin 16	<b>+VBATT_U</b>	Power supply for signal
Pin 7	<b>In4</b>	Gear position "Drive mode"
Pin 34	<b>In5</b>	Gear position "Economy mode"
Pin 20	<b>In7</b>	Gear position "Parking mode"
Pin 8	<b>In6</b>	Gear position "Reverse mode"

When no signal are present the Inverter go in "neutral mode"

When more signal are present the Inverter go in Alarm **A12**.





### 3.3.6 Analog Input

Pin13	<b>X1_Rid_Pot</b>	Reference signal for power limitation
Pin12	<b>X1_REC</b>	Reference signal for regenerative limitation /
Pin42	<b>X1_ACC</b>	Reference signal Accelerator

#### 3.3.6.1 Throttle / Accelerator signal

For control the torque given of the induction motor need to connect a throttle with a linear potenziometer the value between 2Kohm and 5Kohm, take attention to respect the polarity supply.

**WARNING!!!**

If the supply of potenziometer must be reverse the vehicle could go in motion when the Inverter receive the traction enable.

Pin 14	<b>X1+V_ACC</b>	Supply 5Volt for throttle
Pin 28	<b>X1_0V_ACC</b>	Supply 0Volt for throttle
Pin 42	<b>X1_ACC</b>	Reference of throttle /accelerator

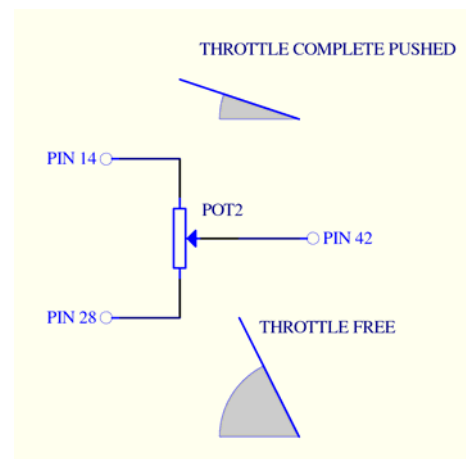

The Parameter **P01** is the corrective **coefficient** of Throttle signal.  
 The Parameter **P02** is the corrective **offset** of Throttle signal.  
 Is possible verify the range of signal on the supervisor by menu' DISPLAY through **D50**.  
 More voltage on **PIN42** result more torque from the motor.

#### 3.3.6.2 Power Limitation

It is possible limit the maxpower supply to induction motor by a linear potenziometer with value between 2Kohm and 5Kohm, take attention to respect the polarity supply.

Pin 27	<b>X1+V_Rid_Pot</b>	Supply 5Volt for Power Limitation
Pin 41	<b>X1_0V_Rid_Pot</b>	Supply 0Volt for Power Limitation
Pin 13	<b>X1_Rid_Pot</b>	Reference of Power Limitation

The Parameter **P03** is the corrective coefficient of Power Limitation signal.  
 The Parameter **P04** is the corrective offset of Power Limitation signal.  
 Is possible verify the range of signal on the supervisor by menu' DISPLAY through **D53**



### 3.3.6.3 Regenerative Limitation

It is possible to limit the maxRegenerative produced from the induction motor by a linear potentiometer with value between 2Kohm and 5Kohm, take attention to respect the polarity supply.

Pin 26	<b>X1+V_REC</b>	Supply 5Volt for Regen Limitation
Pin 40	<b>X1_0V_REC</b>	Supply 0Volt for Regen Limitation
Pin 12	<b>X1_REC</b>	Reference of MaxRegen Limitation

The Parameter **P05** is the corrective coefficient of MaxRegenerative Limitation.

The Parameter **P06** is the corrective offset of MaxRegenerative Limitation.

Is possible to verify the range of signal on the supervisor by menu 'DISPLAY' through **D52**

### 3.3.7 Input PWM Power Limitation

The input PWM is compatible only with signal amplitude of 12 Volt e frequency until 3.3KHz

Pin18	<b>PWM_Rid_Pot</b>	Limitation Power signal
-------	--------------------	-------------------------



### 3.3.8 Logic Output

Pin	Uscita	Descrizione
03	Out2	Inverter Ready
17	Out3	Speed below <b>P50</b>
32	Out6	Enable radiator fan radiator
30	Out7	Output powersteering Renault
25	Out8	Output signal reverse light
36	Out9	Output signal brake light

All the output are Open Drain Type, max current 500mA

#### 3.3.8.1 Inverter Ready

This output tell that Inverter/motor are ready to work.

Pin03      **Out2**      Inverter Ready

#### 3.3.8.2 Speed below P50

This output inform when the speed of the motor is below a know value P50, used with some parking system.

Pin17      **Out3**      Speed below P50

#### 3.3.8.3 Cooling Fan Enable

This output drive by a winding of Relé the work of Fan radiator cooler

Pin32      **Out6**      Cooling fan enable

The Parameter **P257** is the value above that start the cooling Fan.( default 60°C)

The Parameter **P258** is the offset for switch off the Fan.( default 5°C)

#### 3.3.8.4 Power Steering Renault

Output with square wave frequency for manage power steering Renault

Pin30      **Out7**      Output Power Steering Renault

The Parameter **P283** set the frequency of signal (Hz)



### **3.3.8.5 Reverse Light Enable**

This output drive the winding of relé that control the switch on the light of Reverse.

Pin25      **Out8**      Reverse Light Enable

### **3.3.8.6 Brake Light Enable**

This output drive the winding of relé that control the switch on the light of Brake.

Pin36      **Out9**      Brake Light

### **3.3.9 Tachometer Output**

This output is a signal with the frequency is proportional to the speed of the motor

Pin4      **Out-tacho**      Tachometer output

Output push-pull type current max. 200mA, square wave 12Vdc/24Vdc with frequency between 3Hz and 3200Hz .

### **3.3.10 Serial Communication**

Pin24      **RXD**      Reception signal

Pin38      **TXD**      Trasmission signal

Pin23      **GND**      serial Ground

### **3.3.11 CAN-BUS Comunication**

Pin39      **CanH**      Can High

Pin11      **CanL**      Can Low



### 3.3.12 Power Output

Pin	Uscita	Descrizione
01	Out4	Enable the parking system
29	Out5	Disable the parking system

The logic function need to be defined with the customer.

The output are relay outputs, maximum current 5 Amps.

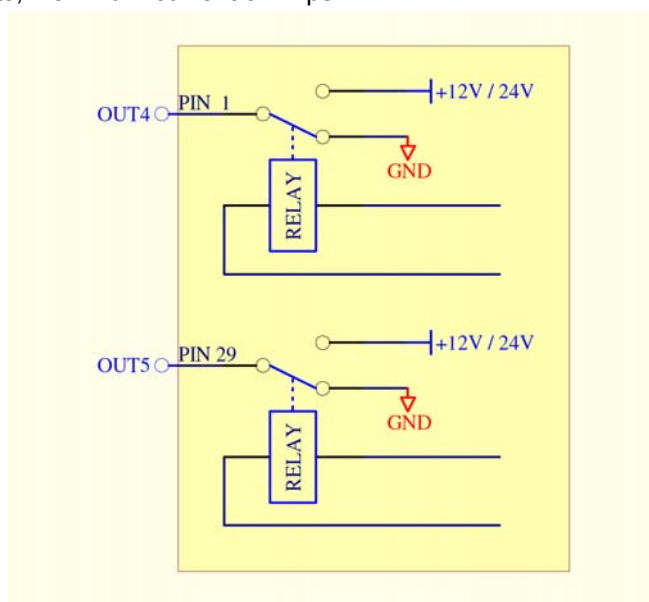

(Photo 9)

#### 3.3.12.1 Parking Enable

This output supply the vehicle parking block device ( max current 5 Amps )

Pin01      OUT4      Parking enable

#### 3.3.12.2 Parking Disable

This output supply the unlock parking device ( max. current 5 Amps )

Pin29      OUT5      Parking disable



### 3.4 Motor Connections

We take MES-DEA motor how reference for explain the necessary connections and trick.

About the connection of the water cooling system, please respect the prescription show in paragraph 3.2

In the picture 8 you can see a new motor just unpack

( Photo 10 )



The motor can be sell alone or with reductor-differential, in the second case it is important respect the right direction of rotation in forward how show in the picture 11.

( Photo 11 )

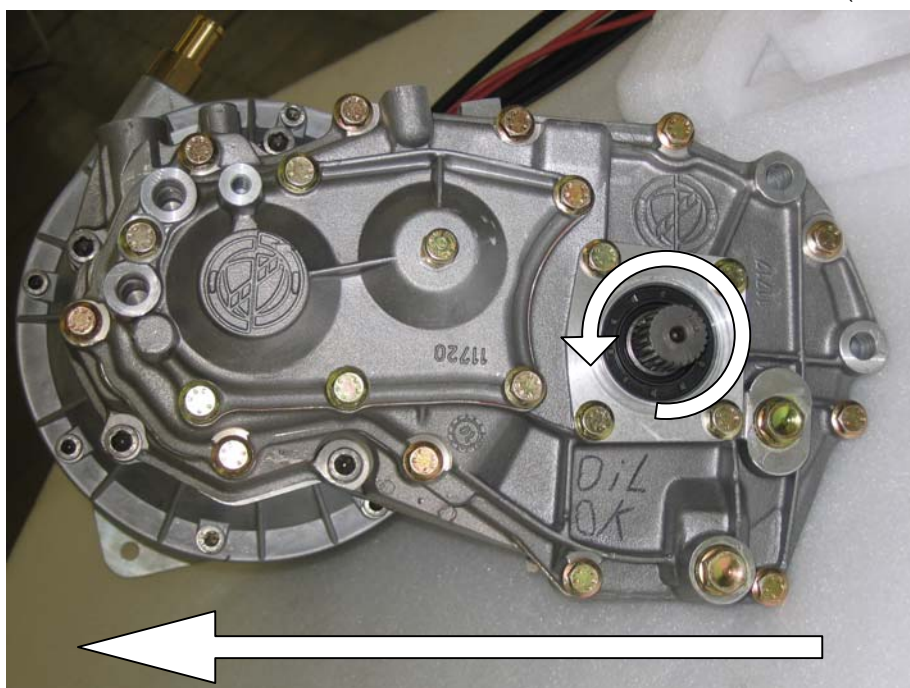

From the motor come out six cable how describe below:

Wire	Description	Color	Section	Length
1	Wire phase U	Black	16 - 25 - 35 mm <sup>2</sup>	1.5 mt
2	Wire phase V	Black	16 - 25 - 35 mm <sup>2</sup>	1.5 mt
3	Wire phase W	Black	16 - 25 - 35 mm <sup>2</sup>	1.5 mt
4	Cable signal NTC	Red	2 x 0.5 mm <sup>2</sup>	1.5 mt
5	Cable signal Termoswitch TS	Red	2 x 0.5 mm <sup>2</sup>	1.5 mt
6	Cable signal Encoder	Black	4 x 0.25 mm <sup>2</sup>	1.5 mt

### 3.4.1 Motor Phase Connection

The 3 phase motor cable must be insert through the PG29 and connect to the contacts labeled U, V, W, warning the cable of the phase V, W before connect must through the respectively Hall Sensor.

look the picture 12.

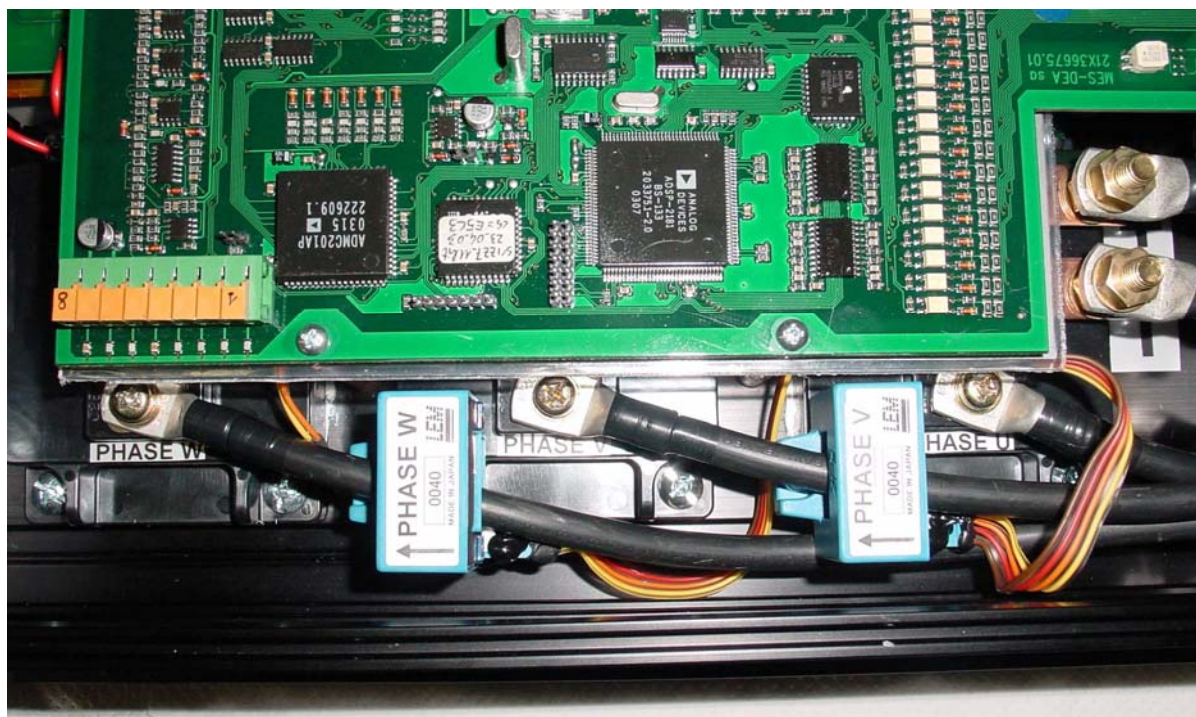

(Photo 12)

Before cut the wire we advice to verify that the rotation of the motor is in right direction.



### 3.4.2 Motor Signal Connection X3 ( 8Contacts )

The connector X3 take all the signal came from the motor, that are: Encoder signal, the termoswitch and the NTC temperature sensor of the winding.

All the motor signal cable must be insert through the PG29

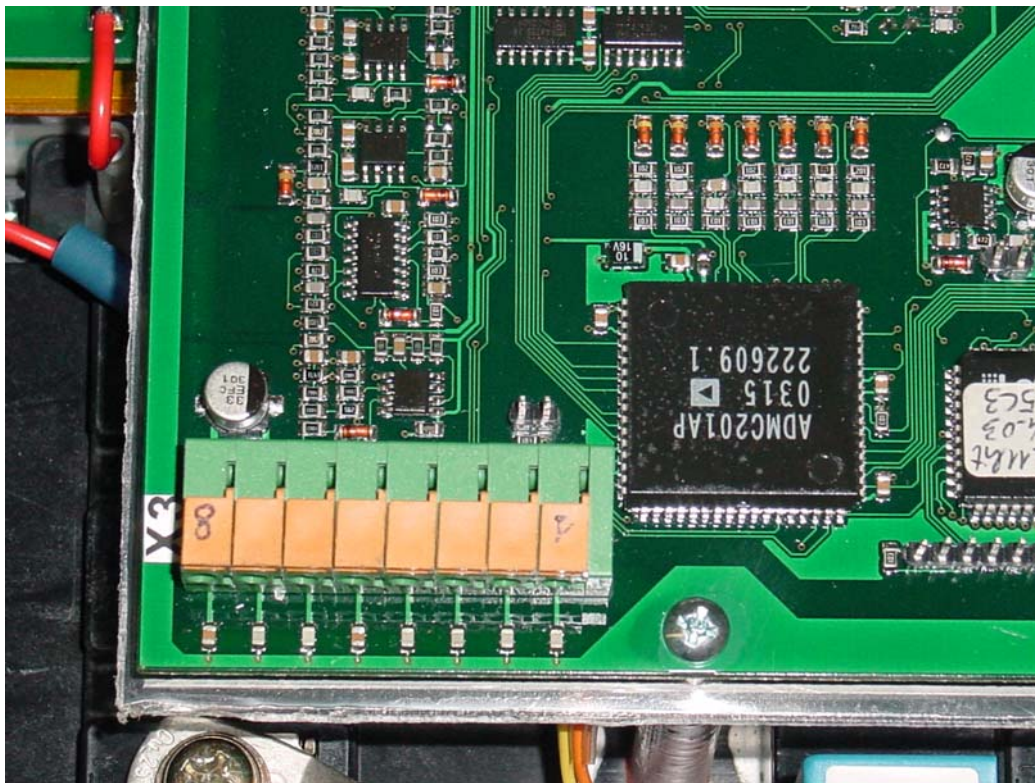

( Photo 13 )

Warning the noise on the motor signal cable could give rough control of the motor at low speed.



### 3.4.2.1 Scheme Connections X3

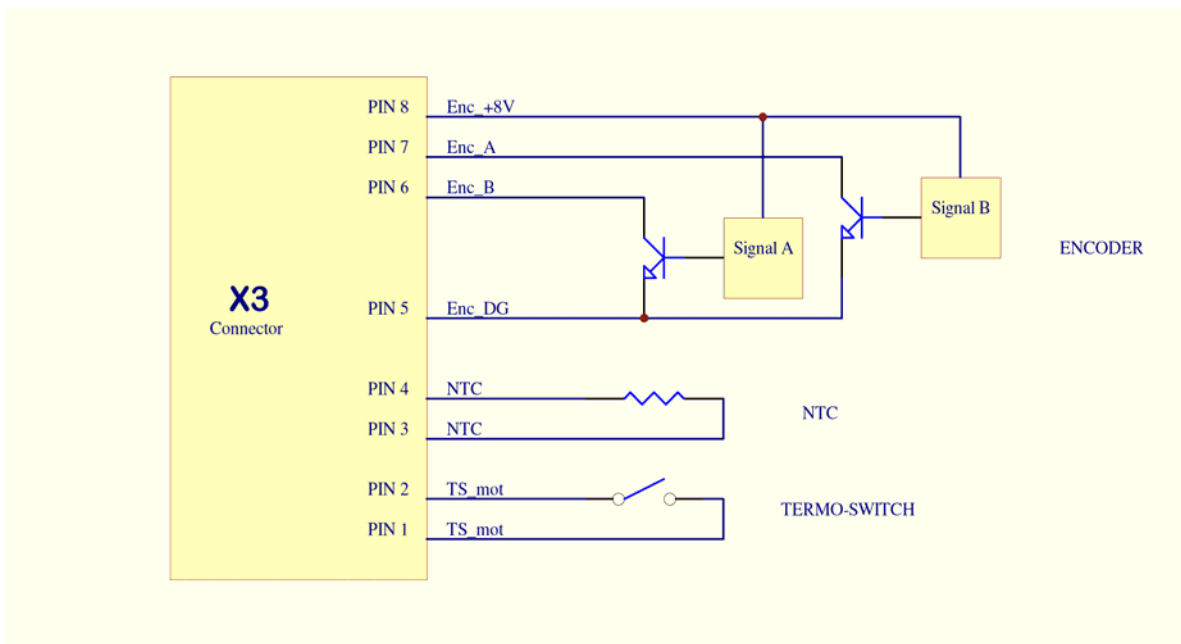

( Photo 14 )

### 3.4.2.2 Signal Table X3

PIN	Description	Color	Function
1	TS_mot	White	Termoswitch motor
2	TS_mot	Brown	Termoswitch motor
3	NTC2	White	NTC2 (motor)
4	NTC2	Brown	NTC2 (motor)
5	Enc_DG	Black	Encoder – ground
6	Enc_B	Blue or Green	Encoder signal B
7	Enc_A	White	Encoder signal A
8	Enc_+8V	Red	Encoder + supply

The sensor speed used in the standard setup is an ENCODER supply 5Vdc with inside two sensor hall that give two square wave ( channel A and channel B dephase of 90° duty cycle 50% - open collector signal ) with 64 pulse turn for each channel.

The dephase between the two signal give us the direction of rotation, while they frequency tell us the value of the speed.

The current compsumtion must be lower of 100mA.



### 3.5 Traction Battery Connection

Before connect the battery cable verify the absence of high voltage on this.

Please use the right size cable for the connections.

We advice to crimp the terminal after through the wire on the PG13.5

For the right function of the inverter connect the wire how show in the picture 15.

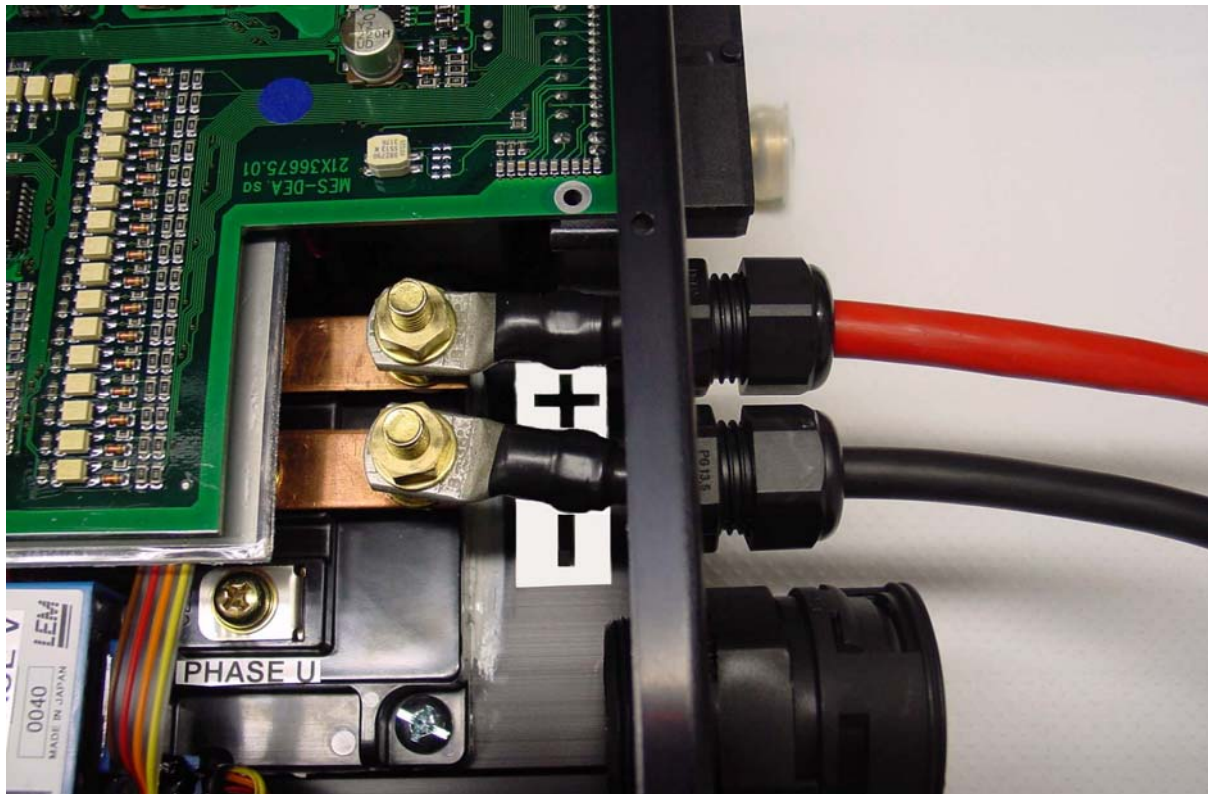

(Photo 15)

It is very important put a protection fuse on the positive, between the Power battery and the Inverter, this for avoid bigger damage in case of anomaly.

## 4 SOFTWARE SUPERVISOR RS-232

This software is your interface with the inverter, by this you can fix all the powertrain function.

The use are easy and the tuning of the motor is rapid, a lot parameter can be customized for meet your requirement, you can look also some dynamic feature.

The communication between the PC and the Inverter is actuate by serial connection RS-232, if in your notebook is not present you can use a USB – RS232 converter.

The software is develop in LabView this is compatible with the following operative system microsoft Windows VISTA, XP, 2000, ME, 98SE, a version for LINUX is working progress.

### 4.1 Installation

The software and other program you need is inside the CD that you find on the last page of the manual.

From the directory **Software Mes-Dea** start the file **setup.exe** and proceed until the complete installation.

Now you can find in program menu a new link **C:\Supervisor\azionamenti\Supervisore INVERTER DSP v1.00.exe** click on this for start the Software Supervisor.



( Photo 16 )

Push the button SERIAL SET-UP



At the first start take attention at the following page setup:

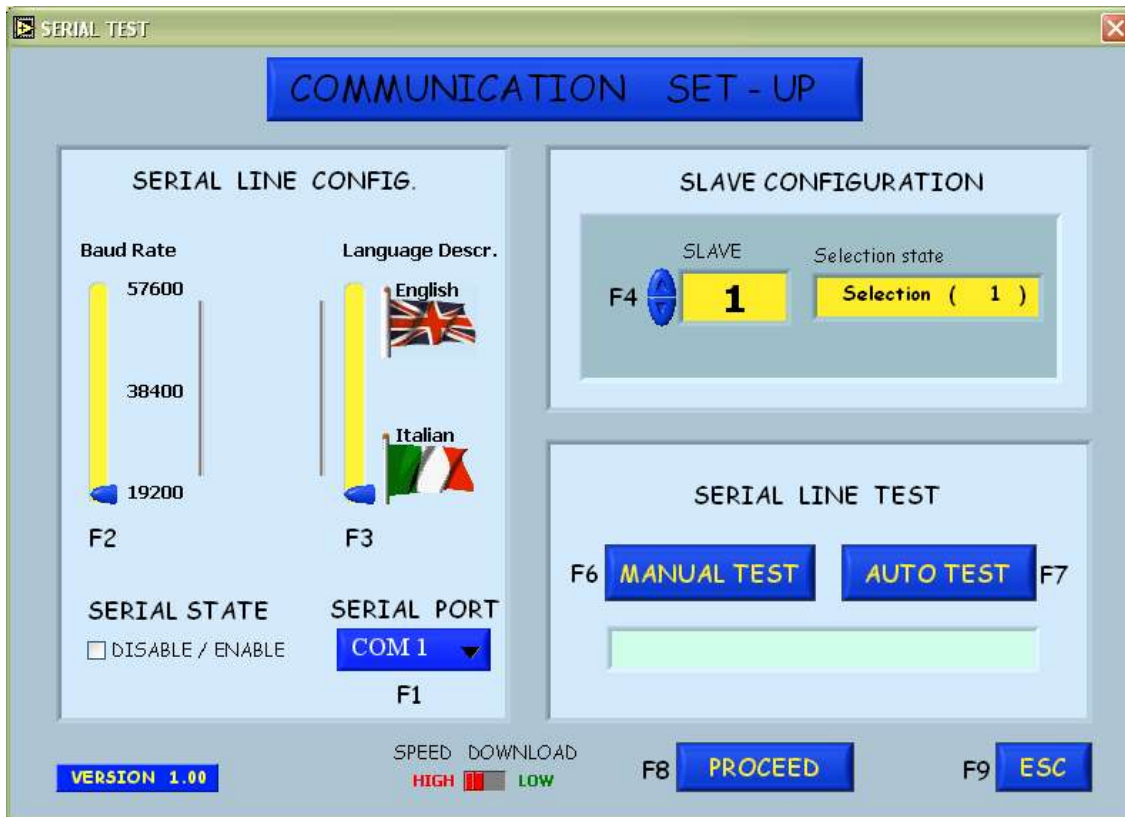

(Photo 17)

Baud Rate : **19200** Standard

Tongue: Italian or English ( Italian is default)

Serial: **COM1, COM2, COM3, COM4** verify this in your PC.

Slave: **1** Standard

Push the button **MANUAL TEST (F6)**

If the serial communication test is pass, the communication label became green.

(If the communication label became red please check the serial setup and if you use a notebook verify that the battery are full, if problem is not resolve verify the voltage value of the service battery on pin15 )

Push the button **PROCEED (F8)**

Start to read all the parameter value inside the inverter and after active all the page of the Software supervisor.



## 4.2 Main Windows ( INTRO )



( Photo 18 )

Now by the buttom present in the high side of the page, You can enter in other windows for proceed with the configuration. Follow the list of windows:

- I/O
- PARAMETERS
- CONNECTIONS
- UTILITY
- ALARMS
- MONITOR
- DISPLAY
- GRAPHIC
- DIAGRAM



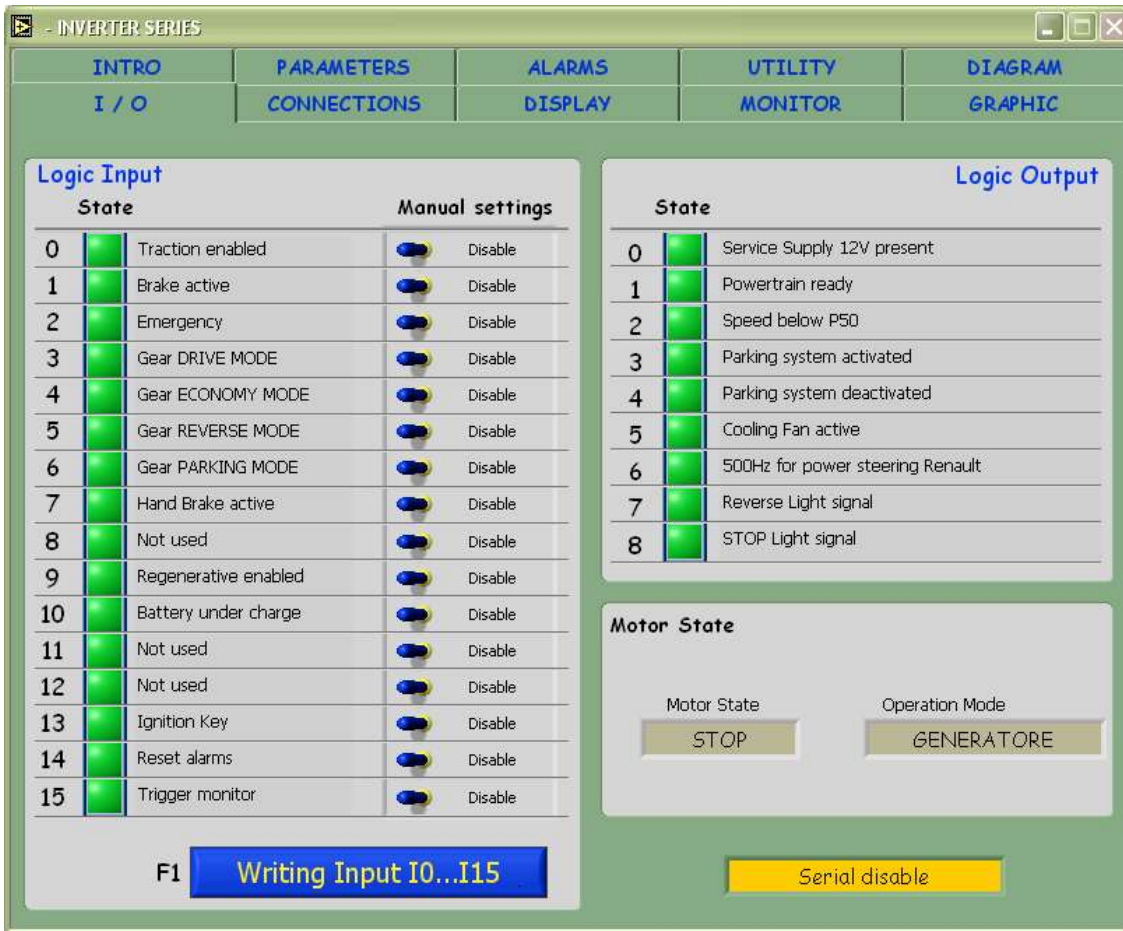

4.2.1 I/O



(Photo 19)

This window show in the left side the state of the input, and the right side the state of the output and also the state of the motor.

 Red mean that the input or the output are active

 Green mean that the input or the output are disable

While the buttom **WRITING INPUT I0..I15 (F1)** is possibile manual enable or disable the input by software.

Example:

Disable the traction by software: think the input logic 0 (marcia) is red, is enough switch the manual setting on disable and push **(F1)** or push the buttom "WRITING INPUT", the color of the flag change in green. The motor state change in stop.

Attention when push **(F1)** all the input chance in function of the manual setting.



## 4.2.2 Parameters

**PARAMETERS**

Parameters selected: P 1, F2 0.0, F3

DESCRIPTION	VALUE	FLAG	MAX	MIN	DEF.
P 0 NON UTILIZZATO vett		Not used			
P 1 Fattore correttivo rif.1 acceleratore [%]		On line	400.0	-400.0	100.0
P 2 Offset correttivo rif.1 acceleratore [+16383=100% <i>n</i> max]		On line	100.0	-100.0	0.0
P 3 Fattore correttivo rif.2 analogico a 14 bit		On line	400.0	-400.0	100.0
P 4 Offset correttivo rif.2 analogico a 14 bit [+16383=100% <i>n</i> max]		On line	100.0	-100.0	0.0
P 5 Fattore correttivo rif.3 analogico a 14 bit		On line	400.0	-400.0	100.0
P 6 Offset correttivo rif.3 analogico a 14 bit [+16383=100% <i>n</i> max]		On line	100.0	-100.0	0.0
P 7 Riferimento di velocità in digitale (JOG) [% <i>n</i> max]		On line	100.00	-100.00	0.00
P 8 Velocità di partenza motopotenziometro [% <i>n</i> max]		On line	100.0	-100.0	2.0
P 9 Costante di tempo filtro sul rif. analogico di coppia [ms]		On line	100.00	-100.00	2.00
P 10 Offset sul riferimento analogico ad alta precisione [/100mV]		On line	19999	-19999	0

**SPECIAL PARAMETERS**

Special Parameters selected: SP 201, F2 0.0, F3

DESCRIPTION	VALUE	FLAG	MAX	MIN	DEF.
P 201 Coppia massima da recupero [% <i>T</i> nom] SPORT		On line	400.0	-400.0	100.0
P 202 Massima velocità [rpm] SPORT		On line	100.0	-100.0	0.0
P 203 Tempo di rampa acc nel funz da motore [s] SPORT		On line	400.0	-400.0	100.0
P 204 Tempo di rampa decc nel funz da motore [s] SPORT		On line	100.0	-100.0	0.0
P 205 Tempo di rampa acc nel funz in recupero [s] SPORT		On line	400.0	-400.0	100.0
P 206 Tempo di rampa decc nel funz da freno [s] SPORT		On line	100.0	-100.0	0.0
P 207 Coppia massima da motore [% <i>T</i> nom] ECONOMY		On line	100.00	-100.00	0.00
P 208 Coppia massima da freno [% <i>T</i> nom] ECONOMY		On line	100.0	-100.0	2.0
P 209 Massima velocità [rpm] ECONOMY		On line	100.00	-100.00	2.00
P 210 Tempo di rampa acc nel funz da motore [s] ECONOMY		On line	19999	-19999	0
P 211 Tempo di rampa decc nel funz da motore [s] ECONOMY		On line	16383	-16383	100

Serial disable      AUTOTUNING AND SAVE

(Photo 20)

Through this window is possible read and modify a lot parameters of the Inverter.

There are three type of parameters (FLAG):

**On-line** These can be change in real time whitout special permission.

**Reserved** Need before insert the User active Password **P60 = 95**, for have the permission to modify.

**Tde** Need to call the MES DEA technicians for analyse together the problem and have the Programmer Password, for actuate the modification the traction must be disable.

Other parameters are change from the system when you make the autotuning.



### 4.2.3 Connections

DESCRIPTION	VALUE	FLAG	MAX	MIN	DEF.
C 0 Visione automatica grandezze interne vett.		On line	63	0	21
C 1 Significato ingresso logico 1		Reserved(r)	28	0	9
C 2 Significato ingresso logico 2		Reserved(r)	28	0	10
C 3 Significato ingresso logico 3		Reserved(r)	28	0	6
C 4 Significato ingresso logico 4		Reserved(r)	28	0	0
C 5 Significato ingresso logico 5		Reserved(r)	28	0	3
C 6 Significato ingresso logico 6		Reserved(r)	28	0	12
C 7 Significato ingresso logico 7		Reserved(r)	28	0	2
C 8 Significato ingresso logico 8		Reserved(r)	28	0	8
C 9 Definizione ingresso in frequenza: 0=analogico 1=digital encoder 2=digital f/s.		Reserved(r)	2	0	1
C 10 Significato uscita logica 1		Reserved(r)	31	-32	3

( Photo 21 )

By this window is possibile look and modify all the connections , these are particular function of the Inverter.





#### 4.2.4 Alarms

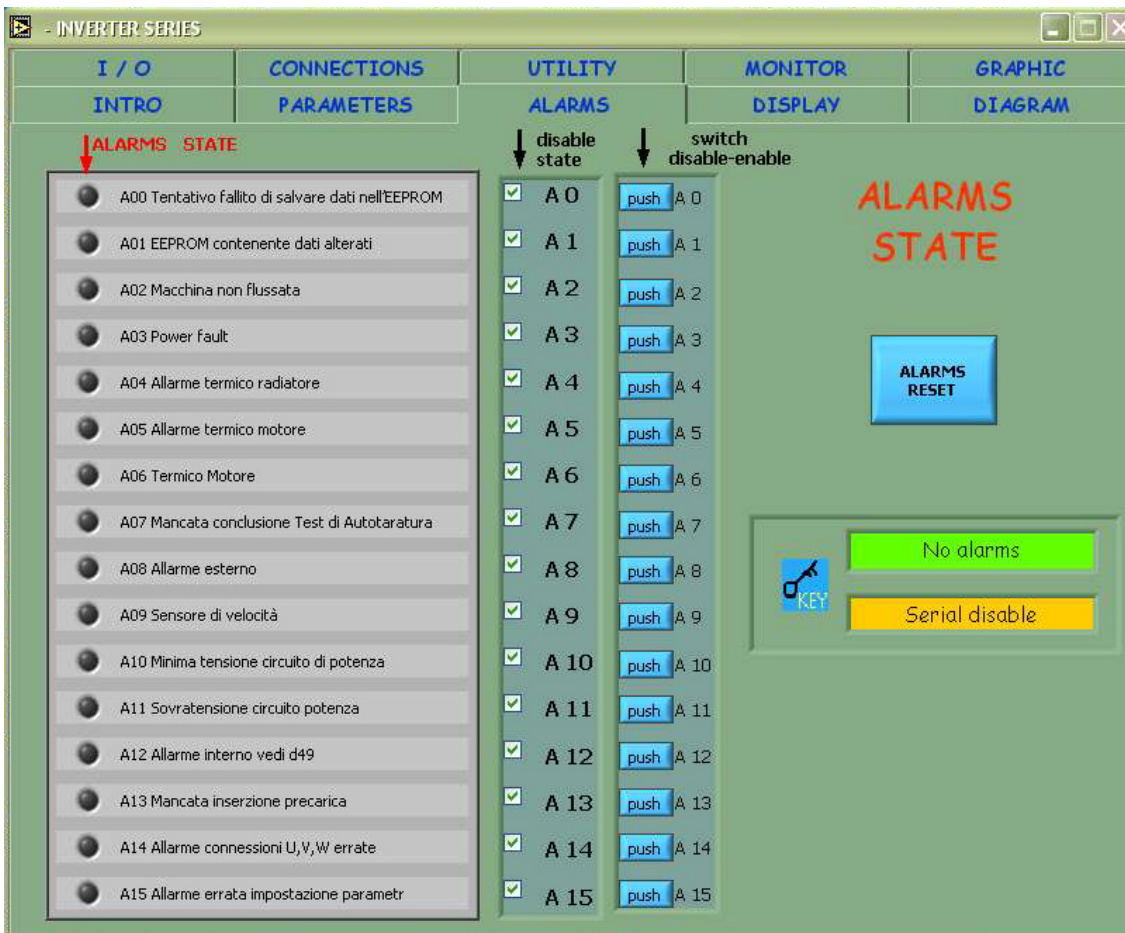

( Photo 22 )

With this page you have a complete vision of Alarm state.

By the button **ALARMS RESET (Fx)** is possible reset the active alarms if the reason of this alarm is disappearance.

#### PROCEDURE for disable a alarm in permanent way.

Supply the inverter

Disable the Traction (see Section 4.2.1)

Insert the password **P60 = 95** (see section 4.2.4)

Open the page alarms

Push the button **PUSH** at the right (**A6 for example**)

Must be appear the approval in the left box

Open the page Parameters

Push the button **AUTOTUNING AND SAVE** this open a new window

Now push the button **C63** and after the button **P263** all the change are saved.

This operation must be do with attention, when you disable an alarm you lost this protection.



### 4.2.5 Display



( Photo 23 )

This page is a lot helpful during the setup of the throttle and in all the situation where need to take the dinamic acquisition for better understand the problem.

You can look three signal in the same time, it is also possible save the chart in excel format for post analysis.



#### 4.2.6 Utility

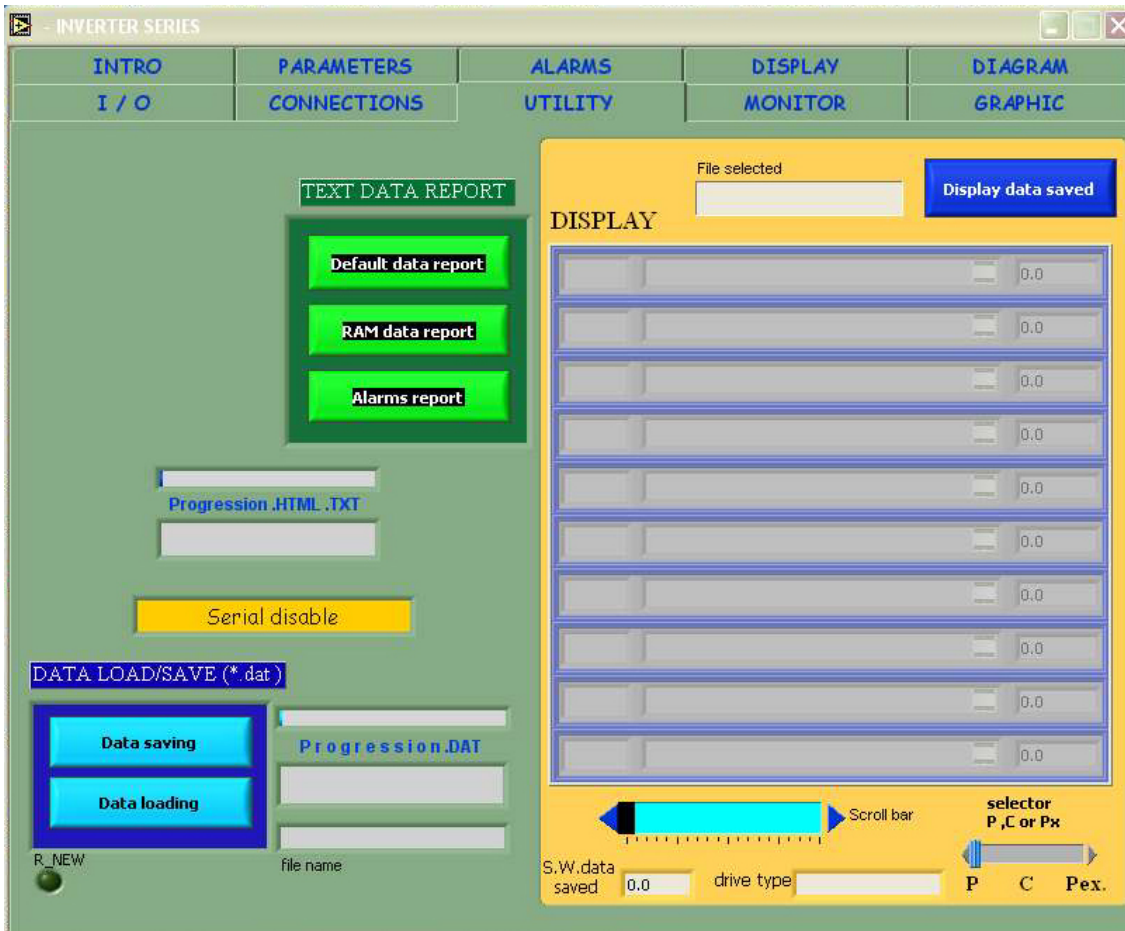

( Photo 24 )

By this window is possible load and save on file your setup for backup or for reloading this on other systems.

Pushing the blue button **DATA SAVING** you can save on the PC your actual recipe (recipe.dat),

by the blue button **DATA LOADING** you can load inside of the Inverter a new recipe from a file on the PC (recipe.dat).

Pushing the green button **RAM DATA REPORT** you can save also a readable file (report.txt) of the setup for easy analyse the data.



### 4.2.7 Monitor

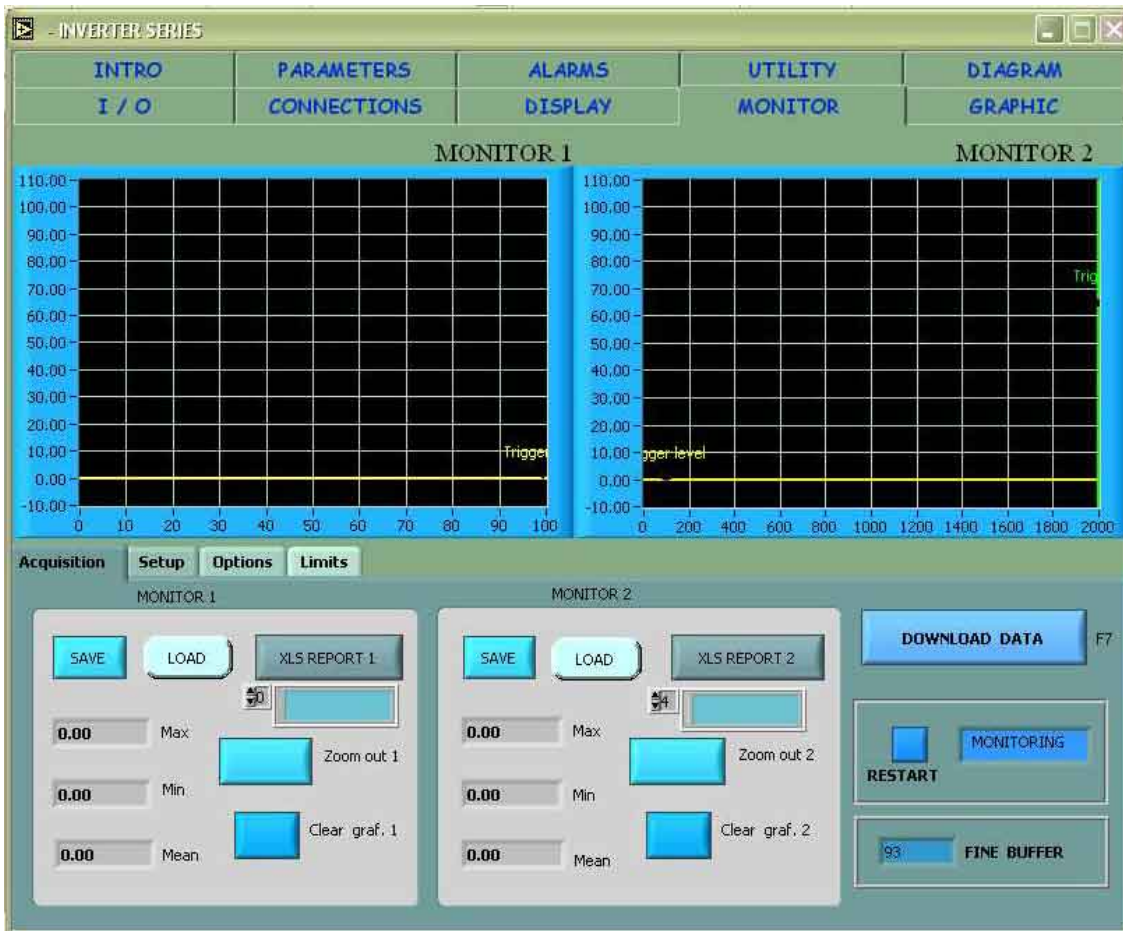

(Photo 25)

This page is used by MES-DEA for analyse and recorder particular customer problem, we can save two signal when happen a particular state.



### 4.2.8 Graphic

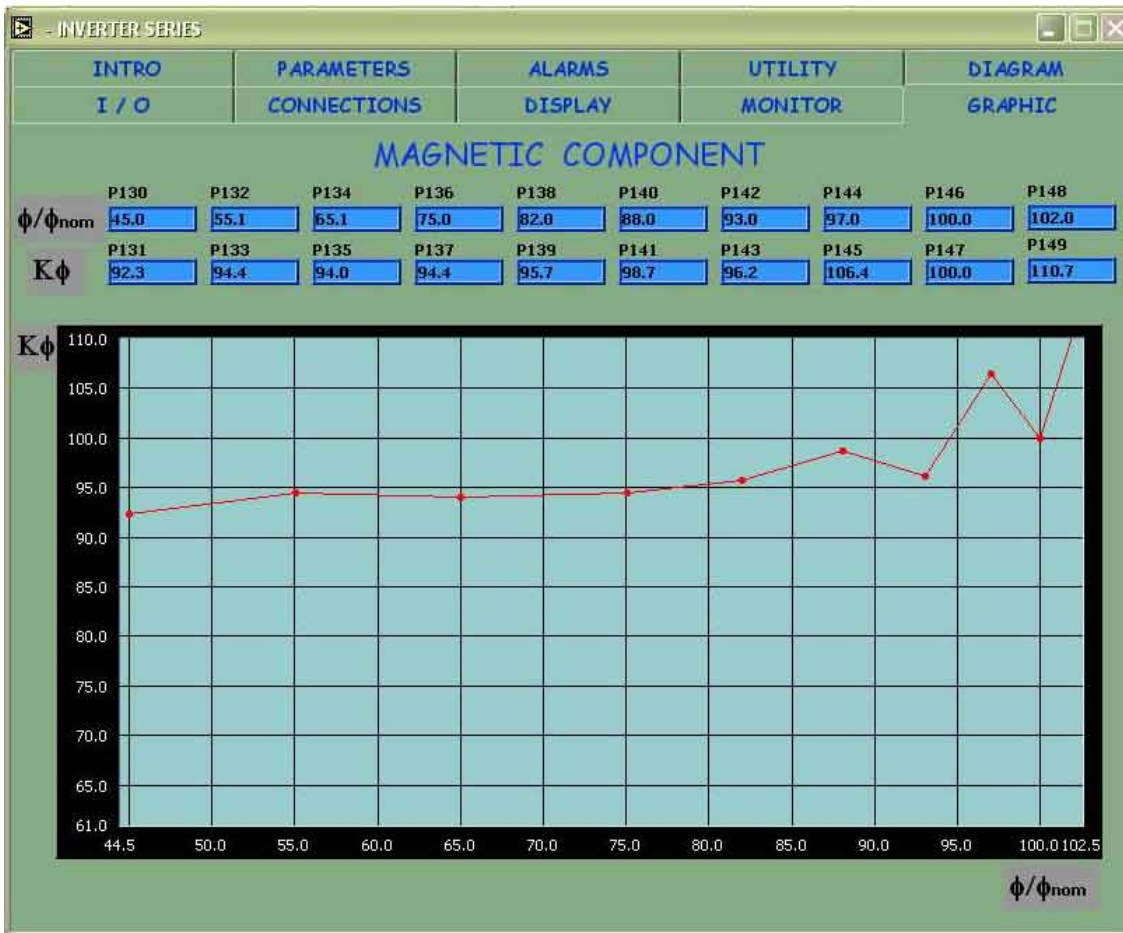

(Photo 26)

This window show the magnetic characteristic of the motor.



### 4.2.9 Diagram

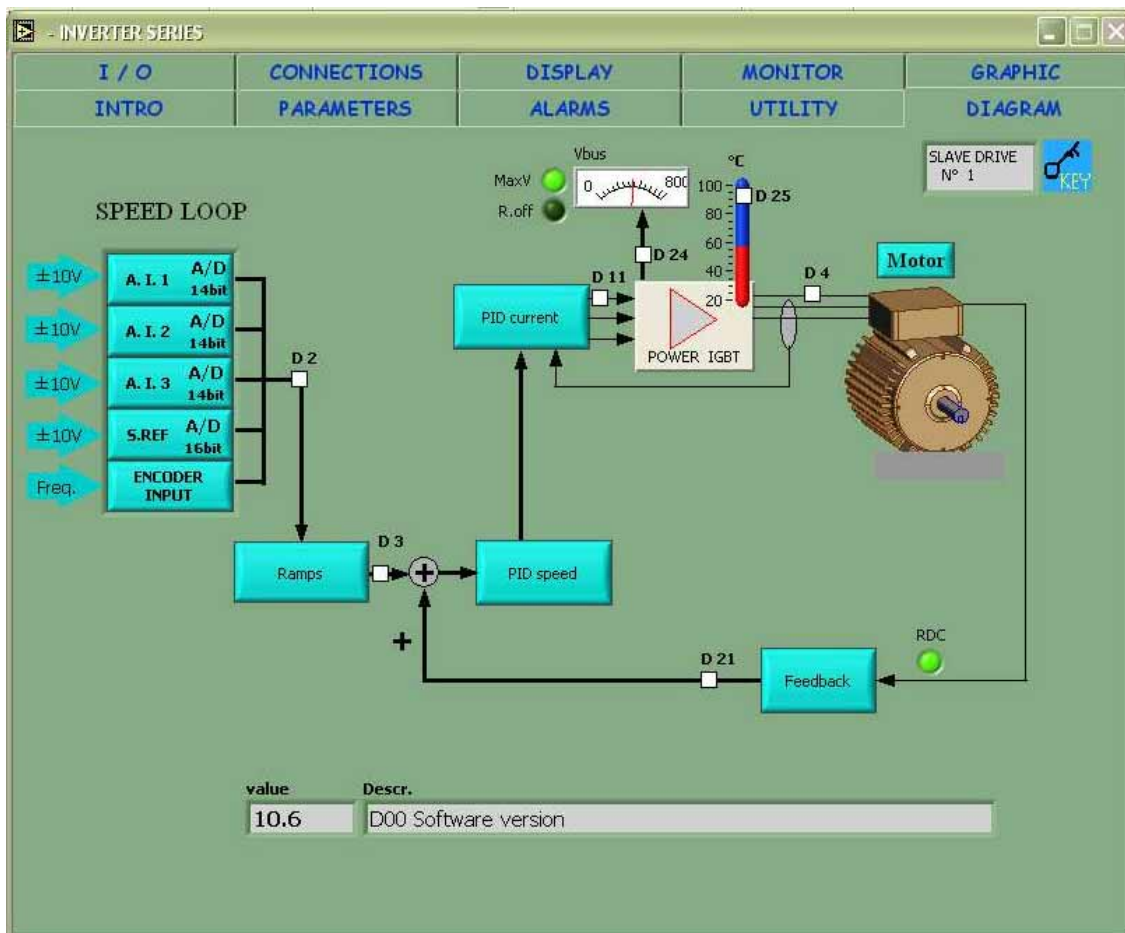

(Photo 27)

This windows show some internal setup by a simple layout.  
 We are working for simplify and ease understand our system.  
 This page is working progress.



#### 4.2.10 Save



( Photo 28 )

It's possible save in permanent mode the change inside the EEPROM memory, between the button **AUTONUNING AND SAVE** in low right side of the page **PARAMETERS** in this way you can be sure to have saved all the modification.

Before to save insert the password **P60 = 95** otherwise the action are not complete!

Disable the traction by software using the page **I/O** or by hardware using the **PIN33**

Now push the button **C63** and after the button **P263** all the change are saved.

For save all change on the connections and on all the Parameters between **P0 – P199** push the button **C63**

For save all change on the Parameters between **P200 – P299** push the button **P263**



## 5 INVERTER SETUP

Before start with the setup be sure that the vehicle is put in safe condition.

We advice to lift the vehicle from the ground or wherever live free to run the traction wheels in safe condition, this for avoid danger state due to the wheels turns between the setup.

Supply +12Volts to Pin31 "Ignition Key"

Start the software supervisor:

Verify in page **ALARMS** that there are not active flag (all green OK) ,

from the page **I / O** disable the traction signal.

### 5.1 Insert Battery data

If you use the CAN-BUS jump this section because this data are update continuos by CAN , otherwise need to insert some parameter that fix the correct range of battery work.

The parameter **P241** define the max voltage battery.

The parameter **P242** define the min. voltage battery.

What mean above P241 and below P242 the inverter limit the torque available for take the voltage bus between the operative range.

You can see battery voltage value in page **DISPLAY** dimension **D24**

The parameter **P238** enable the Voltage Battery protection by torque limitation.

The parameter **P247** define the max current can be request from the battery and the parameter **P248** define the max current can charge the battery in regenerative mode.

It is possibile look the estimate current battery value through page **DISPLAY** dimension **D54**.

### 5.2 Throttle Calibration

From page **DISPLAY** is possible look the accelerator range through dimension **D50**.

The parameters **P224** e **P225** define the operative range of the throttle respectively min. and max., if the reference go above the 100 mean there is a malfunction and the system give **alarm A12** internal alarm, by page **DISPLAY** dimension **D49** you read 3.

Default Value:

The parameter **P01** is the corrective coefficient of the accelerator reference ( **default P01=100** ).

The parameter **P02** is the corrective offset of the accelerator reference ( **default P02=0** ).

The parameter **P224** is the min. value acceptable of the accelerator ( **default P224=0** ).

The parameter **P225** is the max. value acceptable of the accelerator ( **default P225=97** ).

Rectify **P01** in way to obtain this accelerator range **ACCmax - ACCmin =90** ideal value







## 5.4 Procedure for Motor Calibration

The tuning of the motor is made by two Test:

The Connection test that verify the phase of the motor and the encoder signal to be connect in right way.

The Autotuning test that calculate the right parameter for drive the motor.

### 5.4.1 Test Connections and number Poles verify

First Test to do, is divided in two step:

-Verify the correct connections of the motor phase U,V,W.

-Verify the correct number pole of the motor **P67** and the right number pulse of the encoder **P69**

For a correct tuning need the motor are disconnect from the load.

Insert the password **P60=95**

Disable the traction by hardware Pin33(In1) or by software through the page **I / O**

From the page **Connections** set **C41=1**

Now if you enable the traction by hardware Pin33(In1) or by software through the page **I / O** the test start.

The test consist in a complete turn of the motor at low speed, looking the page **Alarm** you can verify if appear some alarms, if that happen need to verify the type of alarm for find the problem:

-If you have **A7** mean that the TEST is stopped before the end.

- If you have also **A14** mean that the phase U,V,W are connected wrong, try to reverse two phase and repeat the test.

- If you have also **A15** mean you have insert the wrong data in **P67**, **P69** ( number motor pole, number encoder pulse for turn ) or the channel **A** and **B** of encoder are connected reverse.

Need to verify the inset parameters and the wire of the encoder, after repeat the test.

The test have positive results if when the motor stop to turn not appear alarms.



## 5.4.2 Auto-Tuning

This second test measure some fundamental parameters that define the behaviour and the feature of the induction motor used.

### **WARNING!!!**

Before start the test be sure to be in safety condition, the motor will turn at high speed, so verify that the motor is well mount and fixed otherwise this test could be very dangerous .

For the right development of the test need to have the motor free to turn without load.

Insert the password **P60=95**

Disable the traction by hardware Pin33(In1) or by software through the page I / O

From the page **CONNECTION** set **C42=3**

A this point by the enable of the traction Pin33(In1) the test start.

-First step analyse the the stator losses and compensation of dead-time. (The motor not turn this step could take some minutes)

-Second step analyse the inductive losses. (the motor run at low speed)

-Third step measure the right magnetic current and the magnetic behaviour. (The motor run up to the 80% of nominal speed)

-Fourth step measure the rotoric time constant and estimation of statoric time constant. (The motor run up to the 80% of the nominal speed for 16 time).

If you look a alarm **A7** mean the test is stopped before finish.

The test have the positive conclusion if at the end of the test you dont have alarms.

Remember after a positive conclusion need to save the new data inside of EEPROM, this before switch off the system otherwise your lost all the work. ( for Save look page 39)

The value of parameter **P78** tell you the new nominal torque of the motor calculated through the test.



### 5.5 Gear Setup

The system is design for manage 5 Gear positions: Drive, Economy, Reverse, Parking and Neutral. For each position can be set max torque, ramp time, regenerative torque, regenerative ramp time, max speed. By **P228** can be set the max speed accepted for change the gear from drive to reverse (1500 turn/min default value) , if the speed of the vehicle is bigger the of P228 the news position of the gear is freeze until the condition became acceptable.

Example: setup of Drive mode parameters

Parameter	Default Value	Description
P200	= 200 %Tnom	Max Torque in drive mode
P201	= 50 %Tnom	Max Torque in rigerative drive mode
P202	= 9000 RPM	Max Speed in drive mode
P203	= 1 sec.	Time to reach the torque value P200
P204	= 0.5 sec.	Time to decrease the torque from P200 to zero
P205	= 2 sec.	Time to reach the regenerative torque value P201
P206	= 0.5 sec.	Time to decrease the regenerative torque from P201 to zero

The accelerator have two zone the first between 0 and 20%(**P226 default value**) manage the regenerative level that simulate the engine brake in termic motor, second zone is between 20% and 100% and manage the motor torque.

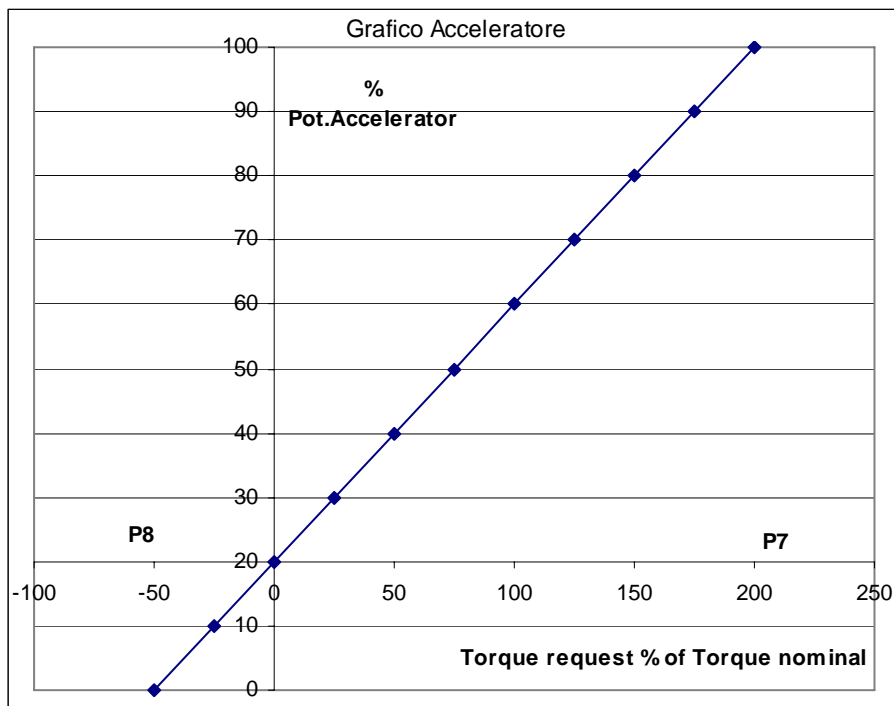

( Photo 29 )



## 5.6 Regenerative Brake setup

the regenerative action activated by the free throttle status can be increase pushing little bit the brake pedal. This function help to decrease the wear out of the brake parts and increase the vehicles safety.

The follow parameters manage this function:

P221	= 70 %Tnom	Max Regenerative Torque in brake status
P222	= 1 sec.	Time to reach the P221 torque value
P223	= 0	Enable the Complementary Logic of Brake signal
P278	= 0.5 sec.	Time to decrease the Regenerative torque to zero.

## 5.7 Tachometer setup

It is possibile modify the frequency of signal tachometer by the coefficient **P265**.

Follow the formula that drive this output :

$$FrequencyOut[Hz] = \frac{MotorSpeed[rpm]}{60} * (64*4) * \frac{P265}{2048} * \frac{1}{16}$$

$$VehicleSpeed[Km/h] = \frac{MotorSpeed[rpm]}{ReductionRate} * 60 * \frac{WheelCircumference[mm]}{1'000'000}$$

For the circumference of wheels look the Tyre Table dimension on appendix.



## 5.8 Setup CAN-BUS

The CAN is enabled by the Connection **C52=1**.

The standard version have all the identifier at 11bit on request how optional is available version at 29 bit

C52 CAN-BUS enable	Options	CAN Status
( 0 – 1 )	0	Disabled
	1	Enabled

The custom can change the speed of the bus by the Connection **C48**, look the table below.

C48 baud rate CAN-BUS Configuration	Options	Baud rate CAN
( 0 – 7 )	0	1 Mbit/s
	1	500Kbit/s
	2	250Kbit/s
	3 std MES-DEA	125Kbit/s
	4	100Kbit/s
	5	50Kbit/s
	6	20kbit/s
	7	10kbit/s

It is possible define the CAN protocol Format used by **P281**:

The standard MES-DEA, use the messages organized in word-oriented (16bit controller) and the distribution of the bit on the 2 Bytes follow the INTEL standard (low-byte on lower, high byte on higher address).

Otherwise is available the Motorola Forward protocol Format.

P281 CAN-BUS protocol	Options	CAN Status
( 0 – 1 )	0 std MES-DEA	INTEL Standard
	1 optional	MOTOROLA Forward



### 5.8.1 Message Rx

These are the message received from the CAN to the Inverter : **M1, M2, M3, stop Tx.**

**M1** Define the max power that could be required to the battery:

Name Message: <b>M1</b>	Method: Broadcast mode	Identifier: <b>0302H</b>			
Repetition rate: 135ms	Delay between single messages: 30ms				
Name signal	Description	Byte Nr	Bit Pos	Bits	Type
		0	0		
		2	16		
Sys_voltageMinDischarge	Min. discharge voltage (resolution 0,1V) P242	4,5	32	16	Unsigned short
Sys_currentMaxDischarge	Max. discharge current (resolution0,1A) P247	6,7	48	16	Unsigned short

**M2** Define the max power that the Inverter could send to the battery and other setting:

Name Message: <b>M2</b>	Method: Broadcast mode	Identifier: <b>0303H</b>			
Repetition rate: 135ms	Delay between single messages: 30ms				
Name signal	Description	Byte Nr	Bit Pos	Bits	Type
Sys_voltageMaxCharge	Max.regenerative braking vehicle, or fast charge voltage (resolution 0,1V) P241	0, 1	0	16	Unsigned short
Sys_currentMaxCharge	Max.regenerative braking vehicle, or fast charge current (resolution 0,1A) P248	2, 3	16	16	Unsigned short
		4	32	1	
Sys_regenBrakingEnable	Regenerative Braking enabled ( In09)	4	33	1	Bool
Sys_dischargeEnable	Sys_dischargeEnable	4	34	1	Bool

**M3** Define the minimum Voltage using the inverter how generator

Name Message: <b>M3</b>	Method: Broadcast mode	Identifier: <b>0304H</b>			
Repetition rate: 135ms	Delay between single messages: 30ms				
Name signal	Description	Byte Nr	Bit Pos	Bits	Type
sys_voltageMaxGenerator	max. fast charge voltage (resolution 0,1V) P241	0, 1	0	16	Unsigned short



**StopTx** When this signal is present all the transmission from the inverter on CAN are stopped, used for firmware update of other device.

Name Message: <b>StopTx</b>	Method: Broadcast mode	Identifier: <b>P274</b>			
Repetition rate: 135ms	Delay between single messages: 30ms				
<b>Name signal</b>	<b>Description</b>	<b>Byte Nr</b>	<b>Bit Pos</b>	<b>Bits</b>	<b>Type</b>

### 5.8.2 Message Tx

These are the message send from the Inverter to the CAN: **Tx0, Tx1**.

**Tx0** It is possible enable the transmission of this ID by parameter **P266=1**.

P266 Tx0 trasmission enable	Options	CAN Status
( 0 – 1 )	0	disabled
	1	enabled

This message define the status of all input output and alarm present:

Message name: <b>Tx0</b>	Method: Broadcast mode	Identifier: <b>P267</b>			
Repetition rate: <b>P268</b>	Delay between single messages: 30ms				
<b>Signal name</b>	<b>Description</b>	<b>Byte Nr</b>	<b>Bit Pos</b>	<b>Bits</b>	<b>Type</b>
In1	Traction enabled	1	0	1	Bool
In2	Brake active	1	1	1	Bool
In3	Emergency	1	2	1	Bool
In4	Gear DRIVE MODE	1	3	1	Bool
In5	Gear ECONOMY MODE	1	4	1	Bool
In6	Gear REVERSE MODE	1	5	1	Bool
In7	Gear PARKING MODE	1	6	1	Bool
In8	Hand Brake active	1	7	1	Bool
In9	Not used	2	8	1	Bool
In10	Regenerative enabled	2	9	1	Bool
In11	Battery under charge	2	10	1	Bool
In12	Not used	2	11	1	Bool
In13	Not used	2	12	1	Bool
In14	Ignition Key	2	13	1	Bool
In15	Reset alarms	2	14	1	Bool
In16	Trigger monitor	2	15	1	Bool





A0	EEPROM save failed	3	16	1	Bool
A1	EEPROM wrong data	3	17	1	Bool
A2	Motor not fluxed	3	18	1	Bool
A3	Power fault	3	19	1	Bool
A4	Temperature Inverter	3	20	1	Bool
A5	Temperature Motor	3	21	1	Bool
A6	Motor termic protection	3	22	1	Bool
A7	Test connection not finish	3	23	1	Bool
A8	External alarm	4	24	1	Bool
A9	Overspeed	4	25	1	Bool
A10	Under voltage on power circuit	4	26	1	Bool
A11	Over voltage on power circuit	4	27	1	Bool
A12	lternal alarm	4	28	1	Bool
A13	Precharge error	4	29	1	Bool
A14	Wrong connection phase U,V,W	4	30	1	Bool
A15	Wrong motor setting	4	31	1	Bool
Out2	Powertrain ready	5	32	1	Bool
Out3	Speed below P50	5	33	1	Bool
Out4	Parking system activated	5	34	1	Bool
Out5	Parking system deactivated	5	35	1	Bool
Out6	Cooling Fan actived	5	36	1	Bool
Out7	500Hz for power steering Renault	5	37	1	Bool
Out8	Reverse light signal	5	38	1	Bool
Out9	Stop light signal	5	39	1	Bool

**Tx1** It is possible enable the trasmission of this ID by parameter **P269=1**.

P269 Tx0 trasmission enable	Options	CAN Status
( 0 – 1 )	0	disabled
	1	enabled

Define the status of all input output and alarm present:

Name Message: <b>Tx1</b>	Method: Broadcast mode	Identifier: <b>P270</b>			
Repetition rate: <b>P271</b>	Delay between single messages: 30ms				
<b>Name signal</b>	<b>Description</b>	<b>Byte Nr</b>	<b>Bit Pos</b>	<b>Bits</b>	<b>Type</b>
DC Bus	Battery voltage (resolution 0,1V)	0,1	0	16	Unsigned
Vehicle Speed	Speed of vehicle (resolution 1 Km/h)	2	16	8	Unsigned
Motor Speed	Speed of the motor (resolution 1RPM)	3,4	24	16	Unsigned
Torque actual	Actual Motor Torque (resolution 1Nm)	5,6	40	16	Signed
Motor temperature	xxxxxx	7	56	8	Unsigned



## 6 UPDATE FIRMWARE

### 6.1 UPDATE FIRMWARE DSP

Procedure for update the DSP Firmware on the control board.

Copy from the CD the folder Downloader Firmware Update Mes-Dea on your desktop.

From the connector X1 connect the PIN37 to +12V.

Supply the +12V to the Inverter

Enable Ignition Key signal

From the folder Downloader Firmware Update start: **OpenDrive.exe**

Select in the space filename: the source file( es. **dvet\_mes227.LDR**)

It is important that the file is in the same folder of Downloader Firmware Update.



( Photo 30 )

Select the port where you want start the serial trasmission.

Push the button **download**, the progress bar must load until 100% of the file.

Normal not happen alarms, however if the load arrive to 100%, some alarm is not a problem.

Switch off the Inverter and disconnect PIN37 from +12V.

At the next Ignition the Inverter are update, you can control the version of the Firmware on the supervisor page **DISPLAY** dimension D61.



## 6.2 UPDATE FIRMWARE PLD

Procedure for update the PLD Firmware on the control board.

Plug the programmer of PLD to parallel port and switch on the PC.

Start the software **ISP Daisy Chain Download Version 8.2**

The high voltage battery must be disconnect.

Open the cover of inverter “ **ATTENTION!!! – High Voltage possible on the capacitor** “

Insert the connector of the PLD programmer in the right mode take attention looking the photo.

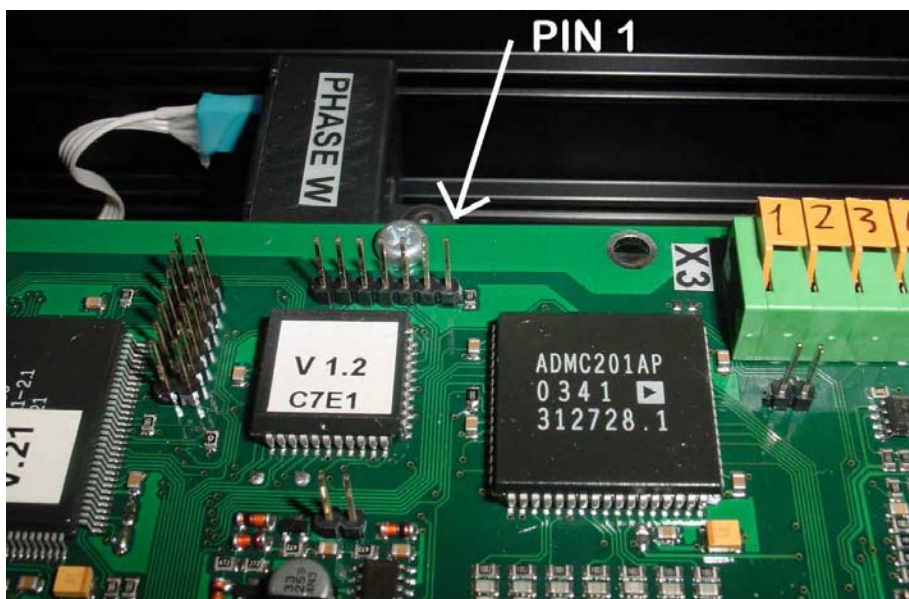

( Photo 31 )

Switch on the +12V Service power Supply

Below the menu **Configuration** select the function **ScanBoard**

In the message window you can look a message of right communication with the device.

**ScanBoard: Successful.**



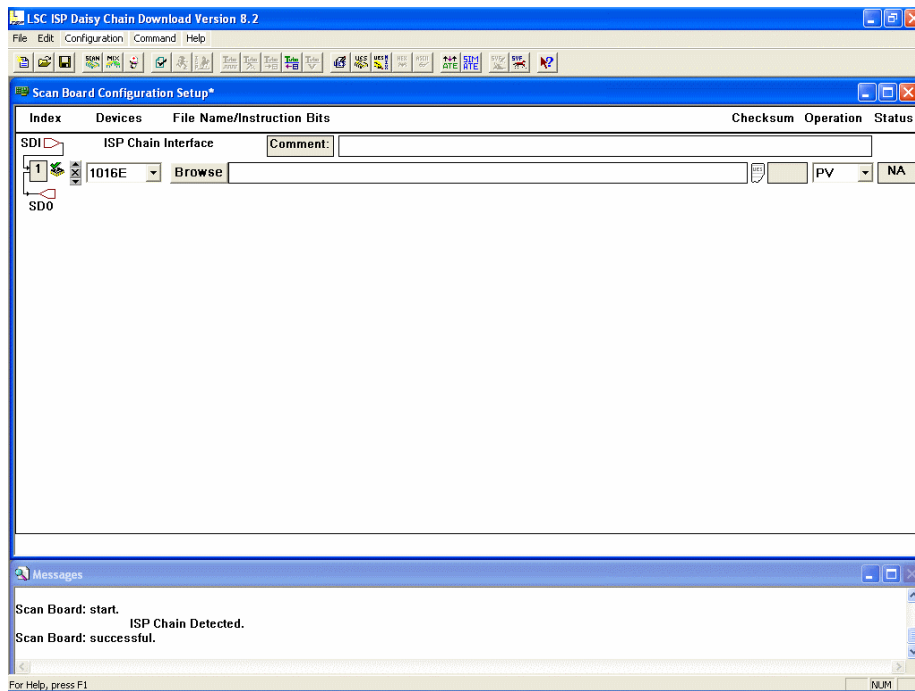

( Photo 32 )

Push the button **Browse** and select the file **Macchina.jed** in the folder **v1\_2\_C7E1**

Push the button **Run Operation** that start the update of the PLD

When the procedure is finish you must read the message :

**Check configuration setup: successful**

**OK operation is done no error turbo download Run**



## 7 TROUBLESHOOTING

### 7.1 Alarms List

ALARMS		DISPLAY => d49
A	0 EEPROM saving failed	
A	1 EEPROM wrong data	
A	2 Motor not fluxed	Flux min < P52 see D27
A	3 Power fault	
A	4 Termic Alarm Inverter	0 = temperature too High 1 = Power istantaneous R brake 2 = Power average R brake
A	5 Termic Alarm motor	D26 > P91
A	6 Termic Motor protection	
A	7 Autotuning stopped before the end	See A14 and A15
A	8 External Alarm	
A	9 Sensor Speed	0 = HW e SW not compatible 1 = sensor not find 2 = overspeed (per 10 T pwm consecutivi)
A	10 undervoltage circuit power	D24 < P106
A	11 Overvoltage circuit power	D24 > P107
A	12 Internal Alarm	0 = C29 diversa da 1 1 = run without precharge 2 = run with Temp. radiator > P119 3 = Throttle /Accelerator 4 = Selector/Gear
A	13 Precharge error	
A	14 Alarm wrong connection of motor phase U, V, W	0 = wrong motor phase 1 = motor not connect
A	15 Alarm wrong motor parameter setup	0 = wrong parameter motor/sensor 1 = impulse encoder simulated 2 = parameter motor (autotuning) 3 = parameter motor/sensor (autotuning)

### 7.2 Discovery and solution fault

### 7.3 Defective handling instruction



## 8 TECNICAL FEATURE

### 8.1 Data-sheet

Name	TIM300		TIM400		TIM600	
MES – DEA Code	30x570__04	30x570__04	30x57034.04	30x570__04	30x57036.04	30x57035.04
Service battery voltage	12V	24V	12V	24V	12V	24V
Power battery voltage	80 - 450Vdc					
Motor Type	Induction Motor with encoder					
Type of Control	FOC					
Sensor Speed	ENCODER 2 channel out of phase of 90°					
Type of modulation	PWM					
Nominal Output Current	140 A rms		186 A rms		266 A rms	
Max Output Current	210 A rms		280 A rms		400 A rms	
Frequency modulation	3 - 9 KHz					
Frequency output	0 - 500 Hz					
IP grade portection	IP 54					
Comunications	RS-232 e CAN-BUS (optional)					
Cooling Type	Liquido ( 50/50 H2O / Glicol )					
Lost pressare	93 mbar @ 8 Litri/min.					
Minimum flow rate required	10 Litri/min.					
Working range Temperature	-20 +65°C					
Dimension of the box	H118xL248xP358 mm					
Dimension with connectors	H118xL248xP386 mm					
Weigh	6.9 Kg.		7.0 Kg.		7.5 Kg.	



**8.2 Dimensions**

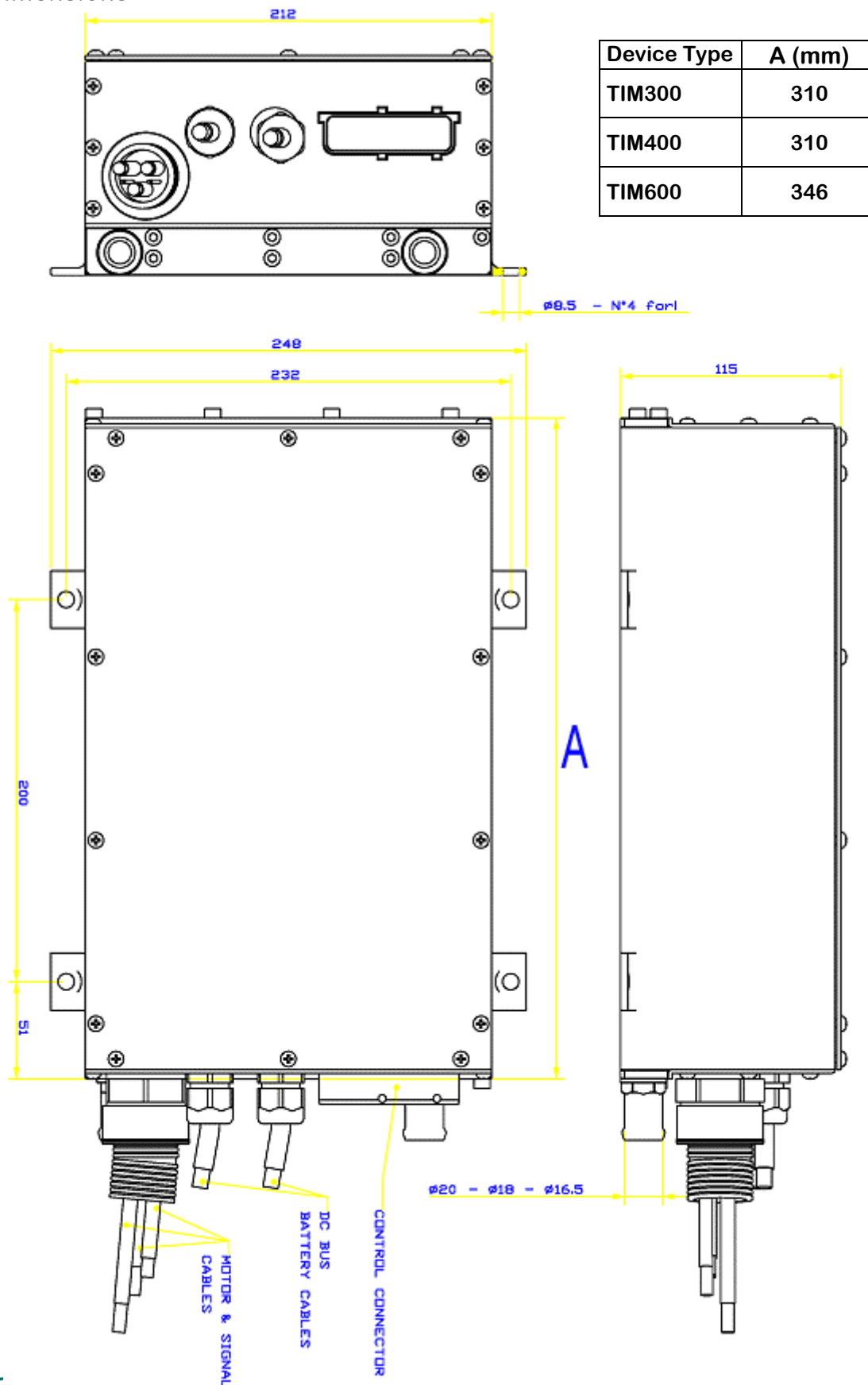

### 8.3 Certifications

The certification ECE / ONU R.85 about:

TIM600 with the motor 200-250W are working progress

TIM600 with the motor 200-330W are working progress

TIM400 with the motor 200-125W are scheduled





## 8.4 Warranty

### WARRANTY

MES-DEA warranty the components against defect of function and production for 24 month from the data of the Invoice how the term detailed in the MES-DEA Sell Conditions

MES-DEA have the right to modify the contents and the specifications of the product without notice.

### NOTE:

Per qualunque chiarimento inviare un E-mail a :

[ucassani@mes-dea.ch](mailto:ucassani@mes-dea.ch)

MES DEA SA  
Via Laveggio 15  
CH 6855 STABIO

TEL +41 (0)91 641 53 11  
FAX +41 (0)91 641 53 33  
E-mail [ucassani@mes-dea.ch](mailto:ucassani@mes-dea.ch)



**APPENDIX:**

**Circumference Tyre Table**

In this table you can find the dimension of the tyre and her circumference for easy calculate and set the speed reference of the vehicle by parameter **P37**.

mm	80	75	70	65	60	55	50	45	40	35
1500	145/80R10		165/70R10			165/55R12				
1520	155/80R10		135/70R12		165/60R12					
1555	125/80R12		145/70R12		155/60R13	165/55R13	175/50R13			
1590	135/80R12		135/70R13 155/70R12		165/60R13					
1630	125/80R13		145/70R13	155/65R13		185/55R13				
1650	145/80R12		165/70R12	175/65R12	175/60R13					
1670	135/80R13		135/70R14 155/70R13	155/65R14 165/65R13	185/60R13	185/55R14 195/55R13		195/45R14		
1675	155/80R12				165/60R14					
1700								195/45R15		
1725	145/80R13		165/70R13	165/65R14 175/65R13	175/60R14 195/60R13	195/55R14				
1750	135/80R14		155/70R14							
1760	155/80R13		175/70R13	175/65R14 185/65R13	185/60R14 205/60R13	185/55R15 205/55R14	195/50R15	195/45R16		
1800	145/80R14		165/70R14	195/65R13	215/60R13			205/45R16		
1815	165/80R13		185/70R13	185/65R14	195/60R14 225/60R13	195/55R15	205/50R15	235/45R15	205/40R17	
1830	135/60R15		155/70R15				215/50R15			
1850	155/80R14 175/80R13		175/70R14 195/70R13	175/65R15 195/65R14	185/80R15 205/60R14 235/60R13	205/55R15 225/55R14	195/50R16 225/50R15	225/45R16	215/40R17 285/40R15	
1875	145/80R15				215/60R14		205/50R16	255/45R15	235/40R17	
1895	165/80R14		185/70R14		195/60R15 225/60R14	215/55R15				
1900	185/80R13		205/70R13							345/35R15



1920	155/80R15		175/70R15							
1930	175/80R14		195/70R14	195/65R15 215/65R14	205/60R15	205/55R16	225/50R16	215/45R17 245/45R16	245/40R17	
1950							205/50R17		225/40R18 255/40R17	
1960								225/45R17	265/40R17	
1970	165/80R15		185/70R15	205/65R15	215/60R15	215/55R16 235/55R15	215/50R17 235/50R16	235/45R17	235/40R18	
1980	185/80R14		205/70R14		245/60R14 225/60R15	225/55R16	225/50R17	245/45R17	245/40R18	275/35R18
2010	175/80R15		195/70R15	215/70R15	215/60R16		255/50R16	255/45R17	255/40R18 285/40R17	295/35R18
2030			215/70R14							
2050	185/80R15		205/70R15	225/65R15	225/60R16 235/60R15 265/60R14	245/55R16	245/50R17 265/50R16 285/50R15		265/40R18	335/35R17
2090	205/80R14		215/70R15 225/70R14		255/60R15	275/55R15	265/50R17			325/35R18
2100	195/80R15	205/75R15			235/80R16					
2130			225/70R15							
2175			235/70R15	255/65R15	255/60R16					
2160	205/80R15	215/75R15								
2205	215/80R15	225/75R15								
2240	205/80R16	215/75R16 235/75R15								
2290	215/80R16									
2350		255/75R15								
2580					345/60R17					



**PARAMETERS TABLE Inverter MES-DEA**
**Parameters on-line**

PAR.	DESCRIZIONE	CAMPO	DEFAULT	RAPPR.
P	1 Fattore correttivo rif. Acceleratore (AN_INP_1) a 14 bit	±400.0	100	%
P	2 Offset correttivo rif. Acceleratore (AN_INP_1) a 14 bit	±16383	0	16383=100%
P	3 Fattore correttivo rif. analogico 2 (AN_INP_2) a 14 bit	±400.0	100	%
P	4 Offset correttivo rif. analogico 2 (AN_INP_2) a 14 bit	±16383	0	16383=100%
P	5 Fattore correttivo rif. analogico 3 (AN_INP_3) a 14 bit	±400.0	100	%
P	6 Offset correttivo rif. analogico 3 (AN_INP_3) a 14 bit	±16383	0	16383=100%
P	7 Riferimento di velocità in digitale (JOG1)	±100.00	0	% n <sub>MAX</sub>
P	8 Velocità di partenza motopotenziometro	±100.0	2	% n <sub>MAX</sub>
P	9 Costante di tempo filtro sul rif. analogico di coppia	0.0÷20.0	0	ms
P	10 Offset sul riferimento analogico ad alta precisione	±19999	0	/100 mV
P	11 NUM – Rapporto scorrimento ingresso in frequenza	±16383	100	
P	12 DEN – Rapporto scorrimento ingresso in frequenza	0÷16383	100	
P	13 Fattore correttivo rif. analogico di velocità a 16 bit	±400.0	100	%
P	14 Offset correttivo rif. analogico di velocità a 16 bit	±16383	0	16383=100%
P	15 Filtro digitale su ingresso logico I08	0.0 ÷ 20.0	2.2	ms
P	16 Massimo rif. di velocità da motopotenziometro	±105.0	105	% n <sub>MAX</sub>
P	17 Minimo rif. di velocità da motopotenziometro	±105.0	-105	% n <sub>MAX</sub>
P	18 Limite massimo riferimento velocità CW	±105.0	105	% n <sub>MAX</sub>
P	19 Limite massimo riferimento velocità CCW	±105.0	105	% n <sub>MAX</sub>
P	20 Tempo di accelerazione potenziometro digitale	0.3÷1999.9	50	s
P	21 Tempo di accelerazione CW	0.01÷199.99	10	s
P	22 Tempo di decelerazione CW	0.01÷199.99	10	s
P	23 Tempo di accelerazione CCW	0.01÷199.99	10	s
P	24 Tempo di decelerazione CCW	0.01÷199.99	10	s
P	25 Costante di tempo filtro arrotondamento	0.1÷20.0	5	s
P	26 Soglia di intervento Relè di corrente/potenza	0.2 ÷ 150.0	100	%
P	27 Costante di tempo filtro per Relè di corrente/potenza	0.1 ÷ 10.0	1	s
P	29 Tempo di attesa magnetizzazione macchina	50 ÷ 3000	300	ms
P	30 Tempo di decelerazione frenata emergenza	0.01÷199.99	10	s
P	31 KpV guadagno proporzionale regolatore di velocità	0.1÷400.0	4	
P	32 TiV costante di anticipo regolatore di velocità	0.1÷3000.0	80	ms
P	33 TfV (filtro) costante di tempo regolatore di velocità	0÷25	0.8	ms
P	35 Flusso di lavoro a coppia costante	0÷120.0	100	% Φ <sub>NOM</sub>
P	36 Kv fattore moltiplicativo tensione ai giri massimi	0.0÷100.0	100	
P	37 Massimo errore inseguimento (parte meno significativa)	0 ÷ 65536	32767	Impulsi giro
P	38 Kv guadagno proporzionale anello di posizione	0.0 ÷ 100.0	4	
P	39 Massimo errore inseguimento (parte più significativa)	0 ÷ 32767	0	Giri
P	40 Limite di corrente	0 ÷ P103	P103	% I <sub>NOM</sub> AZ



P	41	Coppia massima del motore a pieno campo	0 ÷ 800.0	400	% $\tau_{NOM}$
P	42	Coppia massima nel verso positivo di rotazione	0 ÷ 400.0	400	% $\tau_{NOM}$
P	43	Coppia massima nel verso negativo di rotazione	- 400.0 ÷ 0	-400	% $\tau_{NOM}$
P	44	Velocità finale per il cambio guadagni PI velocità	0.0÷100.0	0	% $n_{MAX}$
P	45	KpV guadagno proporzionale iniziale PI velocità	0.1÷400.0	4	
P	46	TiVcostante di anticipo iniziale PI velocità	0.1÷3000.0	80	ms
P	47	Livello soglia velocità per uscita logica o.16	0÷100.0	0	
P	48	Costante di tempo ingresso in frequenza nel tempo	0.0÷20.0	1.6	ms
P	49	Coeff. moltiplicativo ingresso in frequenza nel tempo	0÷200.0	100	
P	50	Livello minima velocità per relè	0÷100.0	2	% $n_{MAX}$
P	51	Livello massima velocità per allarme	0÷125.0	120	% $n_{MAX}$
P	52	Flusso minimo per allarme	0÷100.0	2	% $\Phi_{NOM}$
P	53	Corrente nominale azionamento	0.0÷2000.0		Ampere
P	54	Periodo di campionamento MONITOR	1÷19999	1	$T_{PWM}$
P	55	Punti memorizzati dopo l'evento di trigger MONITOR	1÷2000	1	
P	56	Livello di trigger MONITOR	-200.0÷200.0	0	%
P	57	Val. % corrispondente ai 10V per l'uscita analogica A	100.0÷400.0	200	%
P	58	Val. % corrispondente ai 10V per l'uscita analogica B	100.0÷400.0	200	%
P	59	Isteresi uscite di minima velocità e velocità raggiunta	0.0 ÷ 100.0	1	% $n_{MAX}$
P	60	Chiave di accesso a parametri riservati	0÷19999	P100	

**Parameters Reserved**

PAR.	DESCRIZIONE	CAMPO	DEFAULT	RAPPR.	
P r	61	In motore	1.0÷100.0	100	% $I_{NOMAZ}$
P r	62	Tensione nominale motore	100.0÷1000.0	380	Volt.
P r	63	Frequenza nominale motore	10.0-800.0	50	Hz
P r	64	Tensione massima di lavoro	1.0-200.0	100	% $V_{NOMMOT}$
P r	65	Velocità massima di lavoro	50-30000	2000	Rpm
P r	67	N° poli motore	0÷12	4	
P r	68	N° poli resolver	0÷12	2	
P r	69	N° impulsi giro encoder	0÷60000	1024	impulsi/giro
P r	70	Corrente termica del motore	10÷110.0	100	% $I_{NOMMOT}$
P r	71	Costante di tempo termica del motore	30÷2400	180	s
P r	72	$I_t$ corrente di coppia nominale	0÷100.0	95.2	% $I_{NOMMOT}$
P r	73	$I_u$ corrente magnetizzante	5.0÷100.0	30.2	% $I_{NOMMOT}$
P r	74	Costante di tempo rotorica $\tau_R$	10÷10000	200	ms
P r	75	Costante di tempo statorica $\tau_S$	0.0÷50.0	9.1	ms
P r	76	$\Delta V_{RS}$ %	1.0÷25.0	2	% $V_{NOMMOT}$
P r	77	$\Delta V_{LS}$ %	5.0÷40.0	20	% $V_{NOMMOT}$
P r	78	Coppia nominale del motore misurata	0.5÷3000.0	0	Nm
P r	79	Test connessioni: Encoder: impulsi contati, Resolver o Sin Cos Enc: tempo misurato			
P r	80	Kpi guadagno proporzionale regolatore tensione	0.1÷250.0	10	
P r	81	Tii costante di anticipo regolatore tensione	0.0÷1000.0	200	ms



P r	82	Tfi (filtro) costante di tempo regolatore tensione	0.0÷1000.0	12	ms
P r	83	Kpc guadagno proporzionale regolatore di corrente	0.1÷100.0	2.6	
P r	84	Tic costante di anticipo regolatore di corrente	0.0÷1000.0	9.1	ms
P r	85	Tfc (filtro) costante di tempo regolatore di corrente	0÷25	0	ms
P r	86	Kp3 guadagno proporzionale controllo del Bus	0.05÷10.00	3.5	
P r	87	Tensione di rete (alternata) presente	180.0÷690.0	400	Volt rms
P r	88	Riferimento analogico di velocità ad alta precisione : tensione corrispondente alla massima velocità	2500÷10000	10000	mVolt
P r	89	Banda passante tracking loop decodifica diretta resolver	100÷10000	1800	rad/s
P r	90	Smorzamento tracking loop decodifica diretta resolver	0.00÷5.00	0,71	
P r	91	Temperatura massima motore (se misurata con PT100)	0.0÷150.0	130	Gradi C°
P r	92	N° identificazione seriale	0÷255	1	
P r	93	Baud rate	19.2, 38.4, 57.6	19.2	Kbit/s
P r	95	Valore resistenza NTC o PTC motore per allarme	0-19999	1500	Ω
P r	96	Soglia intervento uscita logica 14 termica motore	0.0÷200.0	100	%P70
P r	97	Livello minimo di tensione per la forzatura del rete-off	0÷1200	425	Volt
P r	98	Riferimento di tensione in Sostegno 1	220÷1200	600	Volt
P r	99	Chiave di accesso ai parametri TDE	0÷19999	-----	

**Parameters Reserved TDE**

PAR.	DESCRIZIONE	CAMPO	DEFAULT	RAPPR.
P t	100	Valore della chiave di accesso ai parametri riservati	0÷9999	95
P t	101	Frequenza PWM	2500÷16000	5000 Hz
P t	102	Compensazione tempi morti	0÷100.0	22 %o V max
P t	103	Il limite azionamento	0÷800.0	150 % I <sub>NOMAZ</sub>
P t	104	Costante di tempo radiatore	10.0÷360.0	80 Secondi
P t	105	Fattore correttivo tensione del Bus	80.0÷120.0	100 %
P t	106	Minima tensione del Bus in continua	180.0÷500.0	400 Volt
P t	107	Massima tensione del Bus in continua	300.0÷1200.0	760 Volt
P t	108	Soglia freno ON	300.0÷1200.0	730 Volt
P t	109	Soglia freno OFF	300.0÷1200.0	710 Volt
P t	110	Offset A/D 1	-100.0÷100.0	0 % Vmax
P t	111	Offset A/D 2	-100.0÷100.0	0 % Vmax
P t	112	Tempo di attesa ritorno allo stato di riposo display	3÷20	10 Secondi
P t	113	Corrente massima azionamento	0÷2000.0	0 Ampere
P r	114	Corrente nel test connessioni UVW , Poli e misura Rs	0÷100.0	100 % I <sub>NOMMOT</sub>
P t	115	Fattore moltiplicativo riferimento analogico PTC/NTC/PT100 motore	0.0÷200.0	100
P t	116	Costante di tempo giunzione	0.1÷10.0	3.5 Secondi
P t	117	Fattore moltiplicativo riferimento analogico PTC/NTC radiatore	0.0÷200.0	100
P t	118	Temperatura massima ammessa da PTC/NTC radiatore	0.0÷150.0	100 Gradi C°
P t	119	Temperatura massima da PTC/NTC rad. Per partire	0.0÷150.0	75 Gradi C°
P t	120	Soglia temperatura radiatore per uscita logica o.15	0.0÷150.0	90 Gradi C°
P t	121	Tempo di accelerazione nei test 3 e 4 di Autotaratura	0.3÷1999.9	4 s



P t	122	Indice di modulazione massimo	0.500÷0.995	0.98	
P t	123	Livello di tensione intervento frenatura intelligente	300.0÷850.0	750	Volt
P t	124	Coeff. moltiplicativo guadagno Kv encoder simulato	0.0÷100.0	100	%
P t	125	Rif. di tensione legato alla Vbus (margine di sicurezza)	0.0÷100.0	96	%
P t	126	KpI coeff. Correttivo Kp stimato per anelli di corrente	0.5÷200.0	100	
P t	127	Kcφ coeff. Correttivo Kp e Tf stimati per anello di flusso	0.5÷800.0	100	
P t	128	K_V_test3_real	0÷100.0	100	
P r	129	Corrente di test per la determinazione della $\Delta V_{LS}$	0÷100.0	30%	% I <sub>NOM MOT</sub>
P t	130	10 coppie di punti			% Φ <sub>NOM</sub>
...	↓	Della			
P t	149	Caratteristica Magnetica			% I <sub>μ</sub>
P r	150	Riferimento analogico di velocità ad alta precisione : taratura VCO per riferimenti di tensione positivi	-16383÷16383	4095	
P r	151	Xb = ampiezza zona di raccordo cubico	0÷50.0	0	% I <sub>NOM AZ</sub>
P r	152	Yc = compensazione alla nominale azionamento	0÷100.0	100	% P102
P r	153	Xoo = ampiezza zona morta	0÷50.0	0	% I <sub>NOM AZ</sub>
P t	154	Tempo di inserzione precarica	150÷19999	250	ms
P t	155	Temperatura ambiente di riferimento (sovraccarico)	0.0÷150.0	40	Gradi C°
P t	156	Frequenza di PWM di caratterizzazione del drive	2500÷16000	5000	Hz
P t	157	Durata tempi morti	0.0÷10.0	4	usec
P t	158	Coeff. correttivo termini di disaccoppiamento	0.0÷200.0	50	
P t	159	Riferimento analogico di velocità ad alta precisione : taratura VCO per riferimenti di tensione negativi	-16383÷16383	4095	
P t	160	Compensazione del ritardo della PWM sulle correnti	-400.0÷400.0	40	% T <sub>PWM</sub>
P t	161	Compensazione del ritardo della PWM sulle tensioni	-400.0÷400.0	50	% T <sub>PWM</sub>
P t	162	ID nodo CAN BUS	1÷127	1	
P r	163	Abilitazione allarmi	-100.0÷100.0		
P r	164	Compensazione ampiezze segnali seno e coseno sensore	0÷32767	16383	1
P r	165	Offset seno incrementale (sin/cos encoder)	-16383÷16383	0	
P r	166	Offset coseno incrementale (sin/cos encoder)	-16383÷16383	0	
P r	167	Valore Resistenza di frenatura	1 ÷ 1000	82	Ohm
P r	168	Massima Energia Adiabatica R frenatura	0.0 ÷ 500.0	4.5	KJoule
P r	169	Tempo di test Energia Adiabatica R frenatura	1 ÷ 30000	2000	ms
P r	170	Potenza media massima dissipabile R frenatura	1 ÷ 30000	150	Watt
P r	171	Costante di tempo Potenza media R frenatura	1 ÷ 2000	720	s
P r	172	Filtro sulla lettura della Vbus	0 ÷ 1000	5	R=Tf/Tc
P r	173	Attesa massima tra 2 byte dello stesso frame seriale	0 ÷ 19000	32	1/10 ms
P	180	----- Riservati all'applicazione -----			

**Table DRIVE mode**

PAR.	DESCRIZIONE	CAMPO	DEFAULT	RAPPR.
P	200 Coppia massima da motore [%Tnom] DRIVE	<input type="checkbox"/>		
P	201 Coppia massima da recupero [%Tnom] DRIVE	<input type="checkbox"/>		
P	202 Massima velocità [rpm] DRIVE	<input type="checkbox"/>		
P	203 Tempo di rampa acc nel funz da motore [s] DRIVE	<input type="checkbox"/>		



P	204	Tempo di rampa decc nel funz da motore	[s]	DRIVE	<input type="checkbox"/>		
P	205	Tempo di rampa acc nel funz in recupero	[s]	DRIVE	<input type="checkbox"/>		
P	206	Tempo di rampa decc nel funz da freno	[s]	DRIVE	<input type="checkbox"/>		

**Table ECONOMY mode**

PAR.	DESCRIZIONE	CAMPO	DEFAULT	RAPPR.
P	207 Coppia massima da motore [%Tnom] ECONOMY	<input type="checkbox"/>		
P	208 Coppia massima da freno [%Tnom] ECONOMY			
P	209 Massima velocita' [rpm] ECONOMY			
P	210 Tempo di rampa acc nel funz da motore [s] ECONOMY			
P	211 Tempo di rampa decc nel funz da motore [s] ECONOMY			
P	212 Tempo di rampa acc nel funz in recupero [s] ECONOMY			
P	213 Tempo di rampa decc nel funz da freno [s] ECONOMY			

**Table REVERSE mode**

PAR.	DESCRIZIONE	CAMPO	DEFAULT	RAPPR.
P	214 Coppia massima da motore [%Tnom] RETRO			
P	215 Coppia massima da freno [%Tnom] RETRO	<input type="checkbox"/>		
P	216 Massima velocita' [rpm] RETRO	<input type="checkbox"/>		
P	217 Tempo di rampa acc nel funz da motore [s] RETRO	<input type="checkbox"/>		
P	218 Tempo di rampa decc nel funz da motore [s] RETRO	<input type="checkbox"/>		
P	219 Tempo di rampa acc nel funz in recupero [s] RETRO			
P	220 Tempo di rampa decc nel funz da freno [s] RETRO			

**Parameters Reserved**

PAR.	DESCRIZIONE	CAMPO	DEFAULT	RAPPR.
P	221 Coppia di frenatura [%Tnom] FRENO		50	
P	222 Tempo di rampa acc nel funz in frenatura [s] FRENO		0.5	
P	223 Abilita logica complementare del freno FRENO		0	
P	224 Minimo valore acceleratore [%] AccELERATORE		0	
P	225 Massimo valore acceleratore [%] AccELERATORE		100	
P	226 Soglia acceleratore motore/freno [%] AccELERATORE		20	
P	227 Soglia limitazione coppia in basso [%]		5	
P	228 Massima velocita' per inserimento della retro [rpm] CAMBIO		1000	
P	229 Tempo massimo ammesso per il cambio [ms] CAMBIO		1000	
P	230 Abilita gestione del cambio impulsivo CAMBIO		0	
P	231 Durata minima impulso del cambio [ms] CAMBIO		10	
P	232 massima velocita' arpionismo [rpm]		10	
P	233 tempo attesa rilascio arpionismo [ms]		100	
P	234 tempo funzionamento uscita OUT_4 [s]		0.1	
P	235 tempo funzionamento uscita OUT_5 [s]		0.1	
P	236 soglia automatica riduzione flusso [%acc]		0.5	
P	237 riferimento flusso ridotto [% flusso nominale]		40	
P	238 Abilita controllo della tensione di batteria		1	
P	239 Guadagno proporzionale controllo tensione di batteria		15	
P	240 Tempo di anticipo controllo tensione di batteria [ms]		10	





P	241	Livello di batteria massimo per la limitazione	[Volt] BATTERIA		350	
P	242	Livello di batteria minimo per la limitazione	[Volt] BATTERIA		60	
P	243	Abilita limite analogico di potenza/corrente			0	
P	244	Abilita complementarieta' limite analogico di potenza/corrente			0	
P	245	Abilita limitazione analogica corrente assorbita batteria			0	
P	246	Coeff. moltiplicativo stima corrente di batteria			100	
P	247	Max corrente assorbita dalla batteria	[Amps] BATTERIA		500	
P	248	Max corrente Rigenerata alla batteria	[Amps] BATTERIA		100	
P	249	Abilita limite analogico del recupero			0	
P	250	Guadagno proporzionale controllo del sovraccarico			1	
P	251	Temperatura di giunzione massima nel sovraccarico			125	
P	252	Soglia switch velocita' piu' o meno filtrate			2.5	
P	253	Cost. di tempo filtro arrotondamento rampe	[ms]		5	
P	254	Cost. di tempo filtro del II ordine velocita' e coppia	[ms]		200	
P	255	Soglia richiesta di coppia per accensione luci di stop			10	
P	256	Isteresi soglia richiesta di coppia per accensione luci di stop			0	
P	257	Soglia intervento circuito di raffreddamento	FAN		60	
P	258	Isteresi intervento circuito di raffreddamento	FAN		5	
P	259	Abilita il riferimento di velocita'			1	
P	260	Scelta riferimento di velocita'	[jog o analogico]		0	
P	261	Carica i default MES-DEA			0	
P	262	Leggi i dati di parametrizzazione MES-DEA			0	
P	263	Salva i dati di parametrizzazione MES-DEA			0	
P	264	Tempo di attesa spegnimento del controllo			4	
P	265	Divisore uscita tachimetrica	TACHO		2047	
P	266	Abilita trasmissione messaggio TX0	CAN		0	
P	267	Id messaggio in trasmissione TX0	CAN		300	
P	268	repetition rate messaggio in trasmissione TX0	CAN		125	
P	269	Abilita trasmissione messaggio TX1	CAN		0	
P	270	Id messaggio in trasmissione TX1	CAN		301	
P	271	repetition rate messaggio in trasmissione TX1	CAN		125	
P	272	byte low messaggio in trasmissione TX1	CAN		52	
P	273	byte high messaggio in trasmissione TX1	CAN		18	
P	274	Idxx messaggio in ricezione per stop trasmissione	CAN		785	
P	275	Scelta messaggio attivo per impostazione Vmax batt			0	
P	276	Costante di tempo filtro del II ordine Vbus	[ms]		1	
P	277	Tempo di attesa nell'inversione della coppia in cicli PWM [7500=1sec.]			1000	
P	278	Tempo di rampa decc nel funz in frenatura	[s] FRENO		0.5	
P	279	Soglia automatica riduzione del flusso	[%]ACCELERATORE		20	
P	280	p280				
P	281	p281				
P	282	p282				
P	283	p283				



**CONNESSIONS TABLE**

CON.	DESCRIZIONE	CAMPO	DEFAULT	
C	0 Visione automatica grandezze interne	0÷63	21	velocità
C	1 Significato ingresso logico 1	-1÷63	8	RESET ALL r
C	2 Significato ingresso logico 2	-1÷63	2	CONSENSO r
C	3 Significato ingresso logico 3	-1÷63	3	ABIL. RIF AI1 r
C	4 Significato ingresso logico 4	-1÷63	0	MARCIA r
C	5 Significato ingresso logico 5	-1÷63	4	ABIL. RIF AI2 r
C	6 Significato ingresso logico 6	-1÷63	12	CW/CCW r
C	7 Significato ingresso logico 7	-1÷63	5	ABIL. JOG r
C	8 Significato ingresso logico 8	-1÷63	22	ABIL. RAMPE r
C	9 Definizione ingresso in frequenza : 0 = analogico; 1 = digital encoder; 2=digital f/s.	0÷2	1	r
C	10 Significato uscita logica 1	-32÷31	3	MARCIA r
C	11 Significato uscita logica 2	-32÷31	0	AZ. PRONTO r
C	12 Significato uscita logica 3	-32÷31	6	FINE RAMPA r
C	13 Significato uscita logica 4	-32÷31	2	VEL SUP MIN r
C	14 Scelta tipologia di TRIGGER 0 ≤ ingressi 1 = 1° allarme 2...31= grandezza analogiche	-31÷63	0	
C	15 Significato uscita analogica programmabile 1	-63÷64	11	CORRENTE
C	16 Significato uscita analogica programmabile 2	-63÷64	4	VELOCITA'
C	17 Significato ingresso analogico A.I.1 a 14 bit 0 = rif. velocità 1 = rif. coppia 2 = rif. limite di coppia	0÷2	0	
C	18 Significato ingresso analogico A.I.2 a 14 bit 0 = rif. velocità 1 = rif. coppia 2 = rif. limite di coppia	0÷2	1	
C	19 Significato ingresso analogico A.I.3 a 14 bit 0 = rif. velocità 1 = rif. coppia 2 = rif. limite di coppia	0÷2	2	
C	20 Carica ultimo valore di frequenza potenziometro digitale	0,1	0	
C	21 Marcia software	0,1	1	
C	22 Abilita riferimento analogico A.I.1 a 14 bit	0,1	0	
C	23 Abilita riferimento analogico A.I.2 a 14 bit	0,1	0	
C	24 Bit parallelo a REF3 (jog)	0,1	0	
C	25 Bit parallelo a REF4 (motopotenziometro digitale)	0,1	0	
C	26 Inclusione rampa	0,1	1	
C	27 Rampa arrotondata	0,1	0	
C	28 Arresto con minima velocità	0,1	0	
C	29 Consenso software azionamento	0,1	1	
C	30 Reset allarmi	0,1	0	
C	31 Abilita riferimento analogico A.I.3 a 14 bit	0,1	0	
C	32 Termico motore → Blocco azionamento ?	0,1	0	
C	33 Scelta della Curva Termica	0÷3	2	



C	34	Gestione della mancanza rete 0 = provo a lavorare; 1 = recupero; 2=libero; 3=frenata di emergenza	0÷3	0	
C	35	Reset automatico degli allarmi al rientro della rete	0,1	0	
C	36	Inversione software del segnale di riferimento	0,1	0	
C	37	Abilitazione Inserzione Precarica	0,1	1	
C	38	Tipologia di partenza con o senza $\Phi$	0÷2	0	
C	39	Scelta impulsi/giro INGRESSO IN FREQUENZA	0÷9	5 = 1024 imp/giro	
C	40	Abilita riferimento analogico di velocità a 16 bit (se presente)	0,1	0	
C	41	Abilitazione test connessioni e n° poli	0,1	0	r
C	42	Abilita Autotarature	0÷3	0	r
C	43	Abilita il riferimento di velocità in frequenza	0,1	0	
C	44	Reset contatori allarmi e salvataggio n° di serie	0,1	0	t
C	45	Ponte raddrizzatore presente 0 = a diodi 1 = semicondrollato	0,1	0	t
C	46	Abilita gestione sonda termica motore (temp in D26) 0=no 1=TS 2=NTC 3=NTC+TS	0÷4	2	
C	47	Abilita frenatura intelligente	0,1	0	r
C	48	Configurazione BAUD RATE CAN Bus 0=1M 1=500K 2=250K 3=125K 4=100K 5=50K 6=20K 7=10K	0÷7	0	r
C	49	Scelta fase zero per ENCODER SIMULATO	0÷3	0	
C	50	Inversione canale B ENCODER SIMULATO	0,1	0	
C	51	Scelta impulsi/giro ENCODER SIMULATO	0÷11	5 = 1024 imp/giro	
C	52	CAN -BUS Enable (0= disable; 1 = enable )	0,1	0	r
C	53	Abilitazione MARCIA con ritenuta	0,1	0	r
C	54	Encoder simulato incrementale o assoluto	0,1	0 (incrementale)	
C	55	Scelta sulla grandezza utilizzata nel Relè di corrente 0 = $ I /I_{NOM\ MOT}$ 1 = $I\tau / I\tau_{NOM}$ 2 = $P / P_{NOM}$	0÷2	0	
C	56	Tipologia di sovraccarico 0=120%×30" 1=150%× 30 2=200%× 30" 3=200%× 3"+155%×30"	0÷3	3	
C	57	Abilita gestione sonda termica radiatore 0=no 1=PTC modulo 2=NTC modulo new 3=NTC rad inverter 4=Tyco (Mini OPD)	0÷4	0	
C	58	Reset CAPTURE MONITOR	0,1	0	
C	59	Disabilita disaccoppiamento dinamico + feedforward	0,1	0	
C	60	Banco di parametri attivo	0,1	0	
C	61	Lettura parametri di default	0,1	0	N
C	62	Lettura parametri da EEPROM	0,1	0	N
C	63	Salva parametri su EEPROM	0,1	0	N
C	64	Abilita controllo di corrente	0,1	0	
C	65	Abilitazione posizionario incrementale ( in // a I17)	0,1	0	
C	66	Fronte di intervento TRIGGER monitor 0 = salita ; 1 = discesa	0,1	0	
C	67	Frequenza della portante del resolver	-3,3	0	r
C	68	Abilitazione autotaratura Sin/Cos Encoder	0,1	0	t
C	69	Abilita filtro del II° ordine sul regolatore di velocità	0,1	0	r



C	70	Abilita riferimento di frequenza nel tempo	0,1	0	
C	71	Abilita bypass theta_precision	0,1	0	r
C	72	Abilita protezione I <sup>2</sup> t resistenza di frenatura	0,1	0	r
C	73	Abilita STOP di sicurezza solo come segnalazione	0,1	0	t
C	74	Abilita gestione nel tempo dell'Encoder Incrementale	0,1	0	r
C	75	Disabilita autotarature partendo dai default	0,1	0	r
C	76	Inverti il senso ciclico positivo	0,1	0	r
C	77	Abilita correzione della memoria della parte integrale del regolatore di velocità su cambio guadagni	0,1	0	r
C	90	----- Riservate all'applicazione -----			



**Table of MEASURE Available on display**

dimensione	DESCRIZIONI GRANDEZZE INTERNE	RAPPRESENTAZIONE	
d	0	Versione software	
d	1	Potenza attiva erogata	KWatt
d	2	Velocità di riferimento prima della rampa	% n <sub>MAX</sub>
d	3	Velocità di riferimento dopo la rampa	% n <sub>MAX</sub>
d	4	Velocità misurata	% n <sub>MAX</sub>
d	5	Richiesta di coppia	% C <sub>NOM MOT</sub>
d	6	Riferimento analogico di velocità a 16 bit	% n <sub>MAX</sub>
d	7	Richiesta di corrente di coppia I <sub>q</sub> rif	% I <sub>NOM AZ</sub>
d	8	Richiesta di corrente magnetizzante I <sub>d</sub> rif	% I <sub>NOM AZ</sub>
d	9	Riferimento di tensione ai giri massimi	% V <sub>NOM MOT</sub>
d	10	Riferimento di coppia (generato dall'applicazione)	% C <sub>NOM MOT</sub>
d	11	Modulo della Corrente	A rms
d	12	Riferimento analogico di velocità a 14 bit	% n max
d	13	Frequenza flusso rotorico	Hz
d	14	Riferimento di velocità in frequenza (generato dall'applicazione)	% n <sub>MAX</sub>
d	15	Componente di coppia della corrente	% I <sub>NOM AZ</sub>
d	16	Componente magnetizzante della corrente	% I <sub>NOM AZ</sub>
d	17	Modulo della tensione storica di riferimento	Volt rms
d	18	Modulo della tensione storica di riferimento	% V <sub>NOM MOT</sub>
d	19	Indice di modulazione	assoluto
d	20	V <sub>q</sub> rif	% V <sub>NOM MOT</sub>
d	21	Velocità di rotazione del motore	rpm
d	22	V <sub>d</sub> rif	% V <sub>NOM MOT</sub>
d	23	Posizione attuale	± 16384
d	24	Tensione di Bus	Volt
d	25	Temperatura del radiatore misurata	Gradi C°
d	26	Temperatura del motore misurata (se C46=1, PT100 presente) Resistenza NTC/PTC (se C46=2 o 3, PTC/NTC presente )	Gradi C° Ω
d	27	Flusso rotorico	% φ <sub>NOM</sub>
d	28	Corrente termica del motore	% soglia intervento A6
d	29	Limite di corrente	% I <sub>NOM AZ</sub>
d	30	Coppia massima	% C <sub>NOM MOT</sub>
d	31	Coppia massima imposta dal limite di corrente	% C <sub>NOM MOT</sub>
d	32	Limite di coppia massima (generato dall'applicazione)	% C <sub>NOM MOT</sub>
d	33	Riferimento di velocità in percentuale (generato dall'applicazione)	% n <sub>MAX</sub>
d	34	Frequenza di scorrimento	Herz
d	35	Coppia erogata	% C <sub>NOM MOT</sub>
d	36	Quota meccanica assoluta sul giro	± 16384
d	37	Quota meccanica assoluta, numero di giri	± 16384
d	38	Potenza media dissipata sulla R frenatura	Watt
d	39	Energia Adiabatica accumulata dalla R frenatura nel tempo di test	KJoule



d	40-47	non utilizzati	
d	48	Numero di serie OPEN drive	
d	49	Codice allarme A12 [1= , 2= , 3=acceleratore, 4=cambio]	
d	50	Riferimento acceleratore %	%
d	51	Richiesta di coppia acceleratore	% C <sub>NOM MOT</sub>
d	52	Lim. del recupero I analogico	% POT <sub>NOM MOT</sub>
d	53	Lim. di potenza I analogico	% POT <sub>NOM MOT</sub>
d	54	Stima corrente assorbita dalla batteria	[AMPS]
d	55	Temperatura di lavoro giunzione IGBT	Gradi C°
d	56-60	Riservate all'applicazione	
d	61	Codice applicazione presente	
d	62	Codice sensore gestito dal firmware	
d	63	Codice sensore gestito dall'hardware	

### Logic Input table

		INGRESSI LOGICI	Connessione logica	
I	00	Marcia	Serie	XI-IN1
I	01	Attiva la frenatura	Parallelo	XI-IN2
I	02	Emergenza	Parallelo	XI-IN3
I	03	Abilita DRIVE mode	Parallelo	XI-IN4
I	04	Abilita ECONOMY mode	Parallelo	XI-IN5
I	05	Abilita RETRO	Parallelo	XI-IN6
I	06	Abilita parking mode	Parallelo	XI-IN7
I	07		Parallelo	XI-IN8
I	08		Parallelo	XI-IN9
I	09	Abilitazione recupero	Serie	XI-IN10
I	10	Ricarica attiva	Parallelo	XI-IN11
I	11			XI-IN12
I	12			XI-IN13
I	13	--- interno --- Presenza chiave		
I	14	Reset allarmi	Parallelo	XI-IN15
I	15	Trigger monitor	Parallelo	XI-IN16

### Logic Output Table

		USCITE LOGICHE	
o	00	--- interna --- chiusura relè alimentazione	
o	01	Azionamento pronto	OUT_2
o	02	Velocità inferiore alla minima	OUT_3
o	03	Arpionismo attivo	OUT_4
o	04	NOT arpionismo attivo	OUT_5
o	05	Attiva circuito di raffreddamento convertitore	OUT_6
o	06	Frequenza di 500Hz per servosterzo	OUT_7
o	07	Cambio in posizione di retromarcia	OUT_8
o	08	Attiva le luci di stop	OUT_9



**ANALOGIC MEASURE available**

GRANDEZZE INTERNE		
0	Posizione meccanica attuale letta dal sensore (se il sensore ha più di 2 poli è relativa al settore di giro attuale)	100%=180° (con 2 poli) 100% = semi-settore (con + poli)
1	Posizione elettrica attuale letta dal sensore (delta m)	100%=180°
2	Riferimento di velocità prima della rampa	% n <sub>MAX</sub>
3	Riferimento di velocità complessivo	% n <sub>MAX</sub>
4	Velocità di rotazione (filtrata T <sub>f</sub> = 8×T <sub>PWM</sub> , 1,6ms a 5KHz)	% n <sub>MAX</sub>
5	Richiesta di coppia	% C <sub>NOM MOT</sub>
6	-- grandezza interna : <i>stato</i> (per MONITOR)	
7	I <sub>q</sub> rif	% I <sub>NOM AZ</sub>
8	I <sub>d</sub> rif	% I <sub>NOM AZ</sub>
9	Richiesta di tensione ai giri massimi	% V <sub>NOM MOT</sub>
10	-- grandezza interna : <i>allarmi</i> (per MONITOR)	
11	Modulo della Corrente	% I <sub>NOM AZ</sub>
12	Top di zero	100%=180°
13	Corrente fase U	% I <sub>MAX AZ</sub>
14	-- grandezza interna : <i>ingressi</i> (per MONITOR)	
15	Componente di coppia della corrente	% I <sub>NOM AZ</sub>
16	Componente magnetizzante della corrente	% I <sub>NOM AZ</sub>
17	Duty-cycle fase U	
18	Modulo della tensione statorica di riferimento	% V <sub>NOM MOT</sub>
19	Indice di modulazione	0 ↔ 1
20	V <sub>q_rif</sub>	% V <sub>NOM</sub>
21	Potenza erogata	% P <sub>NOM</sub>
22	V <sub>d_rif</sub>	% V <sub>NOM</sub>
23	Coppia erogata	% C <sub>NOM MOT</sub>
24	Tensione di Bus	Volt
25	Temperatura del radiatore misurata	% trif (40° x S1 e 37.6° x S2)
26	Temperatura del radiatore stimata	% trif (40° x S1 e 37.6° x S2)
27	Flusso rotorico	% φ <sub>NOM</sub>
28	Corrente termica motore	% soglia intervento A6
29	Limite di corrente	% I <sub>MAX AZ</sub>
30	Coppia massima CW	% C <sub>NOM MOT</sub>
31	Coppia massima CCW	% C <sub>NOM MOT</sub>
32	-- grandezza interna : <i>uscite</i> (per MONITOR)	
33	-- grandezza interna : <i>ingressi_hw</i> (per MONITOR)	
34	Corrente fase V	% I <sub>MAX AZ</sub>
35	Corrente fase W	% I <sub>MAX AZ</sub>
36	Posizione elettrica attuale (alfa <sub>fi</sub> )	100%=180°
37	Ingresso analogico A.I.1	100%=16384
38	Ingresso analogico A.I.2	100%=16384



39	Ingresso analogico A.I.3	100%=16384
40	Ingresso analogico A.I.16	100%=16384
41	Riferimento complessivo di velocità (f_somma_tot) dall'applicazione	% n <sub>MAX</sub>
42	Riferimento complessivo di coppia (t_rif) dall'applicazione	% C <sub>NOM MOT</sub>
43	Riferimento complessivo limite di coppia (limit_i_aux) dall'applicazione	% C <sub>NOM MOT</sub>
44	Riferimento complessivo di velocità (theta_precision) dall'applicazione	Impulsi elettrici per T <sub>PWM</sub>
45	Riferimento per anello di spazio sovrapposto (theta_rif_pos) dall'appl.	Impulsi elettrici per T <sub>PWM</sub>
46	Ampiezza al quadrato dei segnali di retroazione seno e coseno	1=100%
47	Sen_theta (Resolver diretto ed Sin/Cos Encoder)	100%=32767
48	Cos_theta (Resolver diretto ed Sin/Cos Encoder)	100%=32767
49	Velocità di rotazione non filtrata	% n <sub>MAX</sub>
50	Delta impulsi letti nel periodo di PWM nell'ingresso in frequenza	Impulsi per periodo PWM
51	Memoria lsb errore di spazio (anello di spazio sovrapposto)	Impulsi elettrici (x coppie motore)
52	Memoria msb errore di spazio (anello di spazio sovrapposto)	Giri elettrici (x coppie motore)
53	----- Riservate all'applicazione -----	
÷		
63	vedi allegato applicazione	

