

**SERVICE MANUAL**

**INDUSTRIAL DIESEL ENGINE**

**MODEL TNE series**

---

# FOREWORD

*This Service Manual describes the procedure of maintenance and service of the Yanmar industrial TNE series engine (Special swirl precombustion chamber (hereinafter "Indirect injection system") and Direct injection systems).*

*Before starting service and maintenance of TNE engine, you are requested to read this Service Manual carefully to your full understanding and to take careful note that the standard TNE engine may differ in the structure and applicable specification from that loaded on each of individual driven machines (such as the generator, pump, compressor, and combine, etc.).*

*For further information, carefully read the Service Manual issued for each driven machine.*

*This Service Manual in subject to changes, with or without notice, with respect to the structure and the content of maintenance for the purpose of improving engine quality.*

## Setup before work

To perform work efficiently, the following setup (preparation) is necessary.

### 1. Customer ledger check

- (1) Previous date of service
- (2) Check on which month (and at what time) the last service was performed, what problem occurred, and what the history of the customer (engine) is.

### 2. Stock control of parts

- (1) Stock check for consumable parts, periodic replacement parts, etc., that are required for service.
- (2) Provision of check list, parts list and parts card.

### 3. Provision of service record

- (1) Work (process) time table
  - (2) Check sheet (including used parts list)
  - (3) Measurement data of parts
  - (4) Operation data and quality
- } (for maintenance of performance and quality)

### 4. Disassembly and reassembly tools

- (1) Tools
- (2) Measuring devices
- (3) Other instruments and equipment necessary for service



This product has been developed, designed and produced in accordance with the Standards for Quality System of ISO 9001 (International Organization for Standardization) under the following authorized institutions: JMI (Japan Machinery and Metals Inspection Institute), BSI (British Standards Institution) and EQNET (The European Network for Quality System Assessment and Certification).

Certified under the following standards:  
ISO 9001 - 1987 / BS 5750 : Part 1 : 1987 /  
EN 29001 - 1987 / JIS Z9901 - 1991

# CONTENTS

<b>1. Specifications and Performance .....</b>	<b>1-1</b>
1-1 2TNE68 .....	1-1
1-2 3TNE68 .....	1-2
1-3 3TNE74 .....	1-3
1-4 3TNE78A .....	1-4
1-5 3TNE82A .....	1-5
1-6 3TNE82 .....	1-6
1-7 3TNE84 .....	1-7
1-8 3TNE88 .....	1-8
1-9 4TNE82 .....	1-9
1-10 4TNE84 .....	1-10
1-11 4TNE88 .....	1-11
1-12 3TNE84T .....	1-12
1-13 4TNE84T .....	1-13
<b>2. Cross Sectional Views .....</b>	<b>2-1</b>
2-1 Special Swirl Pre-combustion Chamber System .....	2-1
2-2 Direct Injection System .....	2-2
<b>3. Cooling Water, Lubricating Oil and Fuel Oil .....</b>	<b>3-1</b>
3-1 Cooling water .....	3-1
3-2 Lubricating oil .....	3-1
3-3 Fuel oil .....	3-3
<b>4. Troubleshooting .....</b>	<b>4-1</b>
4-1 Trouble causes and remedies .....	4-1
4-2 Trouble diagnosis through measurement of compression pressure .....	4-3
<b>5. Special Service Tools and Measuring Instruments .....</b>	<b>5-1</b>
5-1 Special service tools .....	5-1
5-2 Measuring instruments .....	5-3
<b>6. Measurement, Inspection and Adjustment .....</b>	<b>6-1</b>
6-1 Measuring the compression pressure .....	6-1
6-2 Adjusting the valve head clearance .....	6-3
6-3 Checking the V-belt tension .....	6-4
6-4 Measuring and checking the injection pressure and spray patterns of the fuel injection valve .....	6-4
6-5 Checking and adjusting the fuel injection timing .....	6-8
6-6 Adjusting the no-load maximum (or minimum) revolutions .....	6-10
6-7 Checking the cooling water system and radiator for water leakage .....	6-10
6-8 Checking the battery .....	6-11
6-9 Checking sensors .....	6-13
6-10 Checking the oil cooler .....	6-14
6-11 Checking the piston cooling nozzle .....	6-15

<b>7. Measuring Procedures, Service Data and Corrective Action .....</b>	<b>7-1</b>
7-1 Cylinder head .....	7-1
7-2 Cylinder block .....	7-7
7-3 Valve rocker arm .....	7-10
7-4 Piston and piston ring .....	7-12
7-5 Connecting rod .....	7-17
7-6 Camshaft .....	7-20
7-7 Crankshaft .....	7-22
7-8 Gears .....	7-25
7-9 Trochoid pump .....	7-27
<b>8. Disassembly and Reassembly .....</b>	<b>8-1</b>
8-1 Disassembly .....	8-1
8-2 Precautions before and during reassembly .....	8-6
<b>9. Service Data .....</b>	<b>9-1</b>
9-1 Cylinder head .....	9-1
9-2 Cylinder block .....	9-2
9-3 Valve rocker arm .....	9-2
9-4 Piston .....	9-3
9-5 Piston ring .....	9-4
9-6 Connecting rod .....	9-5
9-7 Camshaft .....	9-5
9-8 Crankshaft .....	9-5
9-9 Side gap and backlash .....	9-6
9-10 Others .....	9-6
<b>10. Tightening Torque .....</b>	<b>10-1</b>
10-1 Main bolt/nut .....	10-1
10-2 Standard bolt and nut .....	10-1
<b>11. Fuel Injection Pump for Indirect Injection System .....</b>	<b>11-1</b>
11-1 Exploded views (YPFR type) .....	11-1
11-2 Disassembly .....	11-2
11-3 Inspection .....	11-3
11-4 Reassembly .....	11-5
<b>12. Fuel Injection Pump for Direct Injection System .....</b>	<b>12-1</b>
12-1 Exploded Views (YPES type) .....	12-1
12-2 Special service tools for disassembly and reassembly .....	12-2
12-3 Disassembly .....	12-3
12-4 Inspection .....	12-7
12-5 Reassembly .....	12-9

<b>13. Governor .....</b>	<b>13-1</b>
13-1 Exploded views of governor for indirect injection system .....	13-1
13-2 Exploded views of governor for direct injection system .....	13-2
13-3 Disassembly .....	13-3
13-4 Inspection .....	13-7
13-5 Reassembly .....	13-9
<b>14. Turbocharger .....</b>	<b>14-1</b>
14-1 Specifications .....	14-1
14-2 Construction .....	14-1
14-3 Waste gate valve adjusting method .....	14-3
14-4 Exploded view of Turbocharger (w/ waste gate) .....	14-5
14-5 Tightening torque .....	14-6
14-6 Service standards .....	14-6
<b>15. Service information for CARB ULG regulation .....</b>	<b>15-1</b>
15-1 Emission control labels .....	15-1
15-2 Limiting the high idle and low idle adjustment screw .....	15-6
15-3 Limiting the fuel volume limiter screw .....	15-7
<b>Attached Drawing 1. Exploded Views of Engine Components .....</b>	<b>A-1</b>
<b>Attached Drawing 2. Exploded Views of Engine Components .....</b>	<b>A-2</b>

○ **Descriptive Breakdown of Model Name**

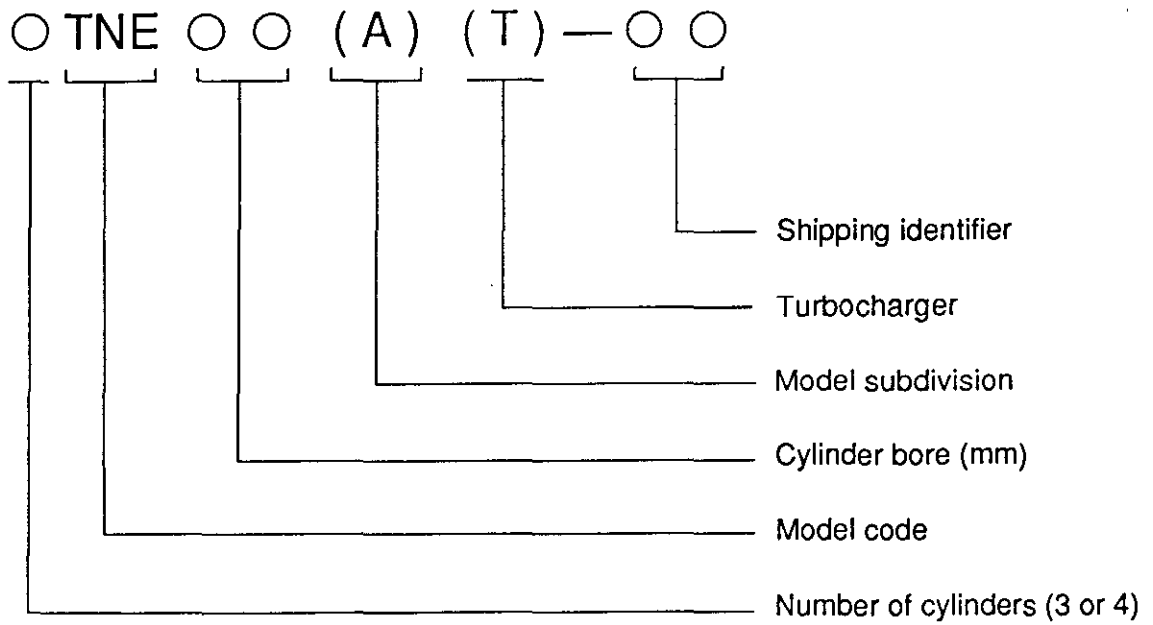

○ **Application Category**

Application code	Usage	Eng. Rev. type	Revolution speed (rpm)
CL	Generator drive	Constant	1500 / 1800
CH			3000 / 3600
VM	General use	Variable	2000 ~ 3000
VH			3000 ~ 3600

\* For engine application category described in Chapter 1, Specifications and Performance.

# 1. Specifications and Performance

## 1-1 2TNE68

\* Output conditions: Intake back pressure ≤ 250 mmAq, Exhaust back pressure ≤ 550 mmAq, other conditions complying with JIS D 1005-1986. After minimum 30 hour's run-in.

Item		Model	2TNE68											
		Unit	VM			CH			VH					
Application		—	VM			CH			VH					
Type		—	Vertical, 4-cycle water-cooled diesel engine											
Combustion system		—	Special swirl pre-combustion chamber											
No. of cylinders – Bore × Stroke		mm	2 – 68 × 72											
Displacement		ℓ	0.523											
Firing order		—	1 – 2											
Revolution speed		rpm	2000	2200	2400	2600	2800	3000	3000	3600	3200	3400	3600	
Output*	Continuous rating	kW(HP)	—	—	—	—	—	—	7.72 (10.5)	9.12 (12.4)	—	—	—	
	Max. rating	kW(HP)	5.74 (7.8)	6.25 (8.5)	6.84 (9.3)	7.43 (10.1)	7.94 (10.8)	8.46 (11.5)	8.46 (11.5)	10.0 (13.6)	8.68 (11.8)	9.19 (12.5)	9.64 (13.1)	
Max. revolution speed at no load		rpm	2180 <sup>+50</sup> <sub>0</sub>	2375 <sup>+50</sup> <sub>0</sub>	2570 <sup>+50</sup> <sub>0</sub>	2780 <sup>+50</sup> <sub>0</sub>	2970 <sup>+50</sup> <sub>0</sub>	3180 <sup>+50</sup> <sub>0</sub>	3180 <sup>+50</sup> <sub>0</sub>	3780 <sup>+50</sup> <sub>0</sub>	3425 <sup>+50</sup> <sub>0</sub>	3640 <sup>+50</sup> <sub>0</sub>	3850 <sup>+50</sup> <sub>0</sub>	
Min. revolution speed at no load			≤800	≤1500			≤800							
Direction of rotation		—	Counterclockwise (viewed from flywheel)											
Power take off		—	Flywheel											
Compression ratio		—	23.0											
Fuel injection timing (FID, b.T.D.C.)		deg	14±1					16±1						
Compression pressure		MPa (kgf/cm <sup>2</sup> )	3.24±0.1 (33±1), at 250 rpm											
Fuel injection pressure		MPa (kgf/cm <sup>2</sup> )	11.8 <sup>+1.0</sup> <sub>0</sub> (120 <sup>+10</sup> <sub>0</sub> )											
Recommended diesel gas oil		—	ISO 8217 DMA, BS 2869 A1 or A2 (Cetane No. 45 min.)											
Lubrication system		—	Forced lubrication with trochoid pump											
Lubricating oil capacity Max/Effective		ℓ	1.6/0.6					2.3/1.0						
Recommended lubricating oil		—	API grade CC class or higher											
Cooling system		—	Liquid cooling/Radiator											
Cooling water capacity		ℓ	0.6 (for engine only)											
Cooling fan No. of blade × dia.		mm	Discharge type, 5 × φ290											
Crank V-pulley dia./ Fan V-pulley dia.		mm	φ95/φ85											
Governor		—	Mechanical centrifugal governor (All speed type)											
Starting system		—	Electrical											
*1 Dimensions L × W × H		mm	373.5 × 417 × 498 / 383.5 × 417 × 498					383.5 × 409 × 540			373.5 × 417 × 540 / 383.5 × 417 × 540			
*1 Dry weight		kg	55 / 65					65			55 / 65			
PERFORMANCE	Governing performance (full speed range)	Transient speed difference	%		≤12					≤10			≤12	
		Steady state speed band	%		≤9	≤8	≤7	≤6	≤5			≤7		
		Recovery time	sec		≤6									
		Fluctuation of revolution	rpm		≤30					≤20			≤30	
L.O. press.	Rated operation	MPa (kgf/cm <sup>2</sup> )	0.25±0.05 (2.5±0.5)		0.29±0.05 (3.0±0.5)			0.34±0.05 (3.5±0.5)						
	Idling		≥0.06 (≥0.6)											

\*1. Designation of engine dimension and dry weight in numerals.

CL/CH application: engine with flywheel housing

VM/VH application: engine with back plate/with flywheel housing

1-2 3TNE68

\* Output conditions: Intake back pressure ≤ 250 mmAq, Exhaust back pressure ≤ 550 mmAq, other conditions complying with JIS D 1005-1986. After minimum 30 hour's run-in.

Item		Model	3TNE68												
		Unit	VM			CH			VH						
Application		—	VM			CH			VH						
Type		—	Vertical, 4-cycle water-cooled diesel engine												
Combustion system		—	Special swirl pre-combustion chamber												
No. of cylinders – Bore × Stroke		mm	3 – 68 × 72												
Displacement		ℓ	0.784												
Firing order		—	1 – 3 – 2 – 1												
Revolution speed		rpm	2000	2200	2400	2600	2800	3000	3000	3600	3200	3400	3600		
Output*	Continuous rating	kW(HP)	—	—	—	—	—	—	11.7 (15.7)	13.7 (18.4)	—	—	—		
	Max. rating	kW(HP)	8.6 (11.5)	9.4 (12.6)	10.3 (13.8)	11.2 (15.0)	12.0 (16.1)	12.9 (17.3)	12.9 (17.3)	15.1 (20.2)	13.1 (17.6)	13.8 (18.5)	14.5 (19.4)		
Max. revolution speed at no load		rpm	2180 <sup>+50</sup> <sub>0</sub>	2375 <sup>+50</sup> <sub>0</sub>	2570 <sup>+50</sup> <sub>0</sub>	2780 <sup>+50</sup> <sub>0</sub>	2970 <sup>+50</sup> <sub>0</sub>	3180 <sup>+50</sup> <sub>0</sub>	3180 <sup>+50</sup> <sub>0</sub>	3780 <sup>+50</sup> <sub>0</sub>	3455 <sup>+50</sup> <sub>0</sub>	3670 <sup>+50</sup> <sub>0</sub>	3890 <sup>+50</sup> <sub>0</sub>		
Min. revolution speed at no load			≤800			≤1500			≤800						
Direction of rotation		—	Counterclockwise (viewed from flywheel)												
Power take off		—	Flywheel												
Compression ratio		—	23.0												
Fuel injection timing (FID, b.T.D.C.)		deg	14±1						16±1						
Compression pressure		MPa (kgf/cm <sup>2</sup> )	3.24±0.1 (33±1), at 250 rpm												
Fuel injection pressure		MPa (kgf/cm <sup>2</sup> )	11.8 <sup>+1.0</sup> <sub>0</sub> (120 <sup>+10</sup> <sub>0</sub> )												
Recommended diesel gas oil		—	ISO 8217 DMA, BS 2869 A1 or A2 (Cetane No. 45 min.)												
Lubrication system		—	Forced lubrication with trochoid pump												
Lubricating oil capacity Max/Effective		ℓ	2.4/1.0						3.0/1.0						
Recommended lubricating oil		—	API grade CC class or higher												
Cooling system		—	Liquid cooling/Radiator												
Cooling water capacity		ℓ	0.9 (for engine only)												
Cooling fan No. of blade × dia.		mm	Pusher type, 5 × φ310												
Crank V-pulley dia./ Fan V-pulley dia.		mm	φ105/φ85												
Governor		—	Mechanical centrifugal governor (All speed type)												
Starting system		—	Electrical												
*1 Dimensions L × W × H		mm	463.5 × 401 × 496 / 473.5 × 401 × 496						473.5 × 401 × 496			463.5 × 401 × 496/ 473.5 × 401 × 496			
*1 Dry weight		kg	70 / 81						81			70 / 81			
PERFORMANCE	Governing performance (full speed range)	Transient speed difference	%		≤12						≤10		≤12		
		Steady state speed band	%		≤9	≤8	≤7	≤6	≤5	≤8					
		Recovery time	sec		≤6										
		Fluctuation of revolution	rpm		≤30						≤20		≤30		
L.O. press.	Rated operation	MPa (kgf/cm <sup>2</sup> )	0.25±0.05 (2.5±0.5)			0.29±0.05 (3.0±0.5)			0.34±0.05 (3.5±0.5)						
	Idling		≥0.06 (≥0.6)												

\*1. Designation of engine dimension and dry weight in numerals.  
 CL/CH application: engine with flywheel housing  
 VM/VH application: engine with back plate/with flywheel housing



## 1-3 3TNE74

\*Output conditions: Intake back pressure  $\leq 250$  mmAq, Exhaust back pressure  $\leq 550$  mmAq, other conditions complying with JIS D 1005-1986. After minimum 30 hour's run-in.

Item	Model		3TNE74												
		Unit	VM			CH			VH						
Application	—		VM			CH			VH						
Type	—		Vertical, 4-cycle water-cooled diesel engine												
Combustion system	—		Special swirl pre-combustion chamber												
No. of cylinders – Bore $\times$ Stroke	mm		3 – 74 $\times$ 78												
Displacement	$\ell$		1.006												
Firing order	—		1 – 3 – 2 – 1												
Revolution speed	rpm		2000	2200	2400	2600	2800	3000	3000	3600	3200	3400	3600		
Output*	Continuous rating	kW(HP)	—	—	—	—	—	—	15.1 (20.2)	17.4 (23.3)	—	—	—		
	Max. rating	kW(HP)	11.0 (14.8)	12.1 (16.2)	13.2 (17.7)	14.3 (19.2)	15.5 (20.8)	16.6 (22.3)	16.6 (22.3)	19.1 (25.6)	16.6 (22.3)	17.1 (22.9)	17.7 (23.7)		
Max. revolution speed at no load	rpm		2180 <sup>+50</sup> <sub>0</sub>	2375 <sup>+50</sup> <sub>0</sub>	2570 <sup>+50</sup> <sub>0</sub>	2780 <sup>+50</sup> <sub>0</sub>	2970 <sup>+50</sup> <sub>0</sub>	3180 <sup>+50</sup> <sub>0</sub>	3180 <sup>+50</sup> <sub>0</sub>	3780 <sup>+50</sup> <sub>0</sub>	3455 <sup>+50</sup> <sub>0</sub>	3670 <sup>+50</sup> <sub>0</sub>	3890 <sup>+50</sup> <sub>0</sub>		
Min. revolution speed at no load	rpm		$\leq 800$						$\leq 1500$			$\leq 800$			
Direction of rotation	—		Counterclockwise (viewed from flywheel)												
Power take off	—		Flywheel												
Compression ratio	—		23.0												
Fuel injection timing (FID, b.T.D.C.)	deg		14 $\pm$ 1						16 $\pm$ 1						
Compression pressure	MPa (kgf/cm <sup>2</sup> )		3.43 $\pm$ 0.1 (35 $\pm$ 1), at 250 rpm												
Fuel injection pressure	MPa (kgf/cm <sup>2</sup> )		11.8 <sup>+1.0</sup> <sub>0</sub> (120 <sup>+10</sup> <sub>0</sub> )												
Recommended diesel gas oil	—		ISO 8217 DMA, BS 2869 A1 or A2 (Cetane No.: 45 min.)												
Lubrication system	—		Forced lubrication with trochoid pump												
Lubricating oil capacity Max/Effective	$\ell$		2.4/1.0						3.3/1.4						
Recommended lubricating oil	—		API grade CC class or higher												
Cooling system	—		Liquid cooling/Radiator												
Cooling water capacity	$\ell$		0.9 (for engine only)												
Cooling fan No. of blade $\times$ dia.	mm		Pusher type, 5 $\times$ $\phi$ 310						Pusher type, 6 $\times$ $\phi$ 335						
Crank V-pulley dia./ Fan V-pulley dia.	mm		$\phi$ 110/ $\phi$ 85						$\phi$ 110/ $\phi$ 97						
Governor	—		Mechanical centrifugal governor (All speed type)												
Starting system	—		Electrical												
*1 Dimensions L $\times$ W $\times$ H	mm		469.1 $\times$ 440 $\times$ 502 / 476.6 $\times$ 440 $\times$ 502						476.6 $\times$ 440 $\times$ 502			469.1 $\times$ 440 $\times$ 502 / 476.6 $\times$ 440 $\times$ 502			
*1 Dry weight	kg		85 / 102						100			85 / 100			
Governing performance (full speed range)	Transient speed difference	%	$\leq 12$						$\leq 10$			$\leq 12$			
	Steady state speed band	%	$\leq 9$	$\leq 8$	$\leq 7$	$\leq 6$	$\leq 5$	$\leq 8$							
	Recovery time	sec	$\leq 6$												
	Fluctuation of revolution	rpm	$\leq 30$						$\leq 20$			$\leq 30$			
L.O. press.	Rated operation	MPa (kgf/cm <sup>2</sup> )	0.25 $\pm$ 0.05 (2.5 $\pm$ 0.5)			0.29 $\pm$ 0.05 (3.0 $\pm$ 0.5)			0.34 $\pm$ 0.05 (3.5 $\pm$ 0.5)						
	Idling		$\geq 0.06$ ( $\geq 0.6$ )												

\*1. Designation of engine dimension and dry weight in numerals.

CL/CH application: engine with flywheel housing

VM/VH application: engine with back plate/with flywheel housing

1-4 3TNE78A

\*Output conditions: Intake back pressure ≤ 250 mmAq, Exhaust back pressure ≤ 550 mmAq, other conditions complying with JIS D 1005-1986. After minimum 30 hour's run-in.

Item		Model	3TNE78A														
		Unit	CL	VM						CH	VH						
Application		—	CL	VM						CH	VH						
Type		—	Vertical, 4-cycle water-cooled diesel engine														
Combustion system		—	Direct injection system														
No. of cylinders – Bore × Stroke		mm	3 – 78 × 84														
Displacement		ℓ	1.204														
Firing order		—	1 – 3 – 2 – 1														
Revolution speed		rpm	1500	1800	2000	2200	2400	2600	2800	3000	3000	3600	3200	3400	3600		
Output*	Continuous rating	kW(HP)	9.1 (12.2)	10.8 (14.5)	—	—	—	—	—	—	18.0 (24.1)	21.0 (28.2)	—	—	—		
	Max. rating	kW(HP)	9.9 (13.3)	11.9 (16.0)	13.2 (17.7)	14.6 (19.6)	15.9 (21.3)	17.2 (23.1)	18.5 (24.8)	19.9 (26.7)	19.9 (26.7)	23.2 (31.1)	20.5 (27.5)	21.6 (29.0)	23.2 (31.1)		
Max. revolution speed at no load		rpm	1575 <sup>+50</sup> <sub>0</sub>	1870 <sup>+50</sup> <sub>0</sub>	2180 <sup>+50</sup> <sub>0</sub>	2375 <sup>+50</sup> <sub>0</sub>	2570 <sup>+50</sup> <sub>0</sub>	2780 <sup>+50</sup> <sub>0</sub>	2970 <sup>+50</sup> <sub>0</sub>	3180 <sup>+50</sup> <sub>0</sub>	3150 <sup>+50</sup> <sub>0</sub>	3745 <sup>+50</sup> <sub>0</sub>	3455 <sup>+50</sup> <sub>0</sub>	3670 <sup>+50</sup> <sub>0</sub>	3890 <sup>+50</sup> <sub>0</sub>		
Min. revolution speed at no load			≤1200	≤800						≤1500	≤800						
Direction of rotation		—	Counterclockwise (viewed from flywheel)														
Power take off		—	Flywheel														
Compression ratio		—	18.0														
Fuel injection timing (FID, b.T.D.C.)		deg	10±1	12±1	14±1	16±1	24±1	18±1	20±1	24±1							
Compression pressure		MPa (kgf/cm <sup>2</sup> )	3.14±0.1 (32±1), at 250 rpm														
Fuel injection pressure		MPa (kgf/cm <sup>2</sup> )	19.6 <sup>+1.0</sup> <sub>0</sub> (200 <sup>+10</sup> <sub>0</sub> )														
Recommended diesel gas oil		—	ISO 8217 DMA, BS 2869 A1 or A2 (Cetane No.: 45 min.)														
Lubrication system		—	Forced lubrication with trochoid pump														
Lubricating oil capacity Max/Effective		ℓ	3.6/1.3						5.0/1.7								
Recommended lubricating oil		—	API grade CC class or higher														
Cooling system		—	Liquid cooling/Radiator														
Cooling water capacity		ℓ	1.8 (for engine only)														
Cooling fan No. of blade × dia.		mm	Pusher type, 6 × φ335														
Crank V-pulley dia./ Fan V-pulley dia.		mm	φ120/φ90	φ110/φ110													
Governor		—	Mechanical centrifugal governor (All speed type)														
Starting system		—	Electrical														
*1 Dimensions L × W × H		mm	553×489×565			520.5 × 489 × 565 / 528 × 489 × 565						528 × 489 × 565		520.5 × 489 × 565/ 528 × 489 × 565			
*1 Dry weight		kg	138			112/128						124		112 / 124			
PERFORMANCE	Governing performance (full speed range)	Transient speed difference	%	≤10	≤8	≤12						≤10	≤8	≤12			
		Steady state speed band	%	≤5	≤4	≤9	≤8	≤7	≤6	≤5	≤4	≤8					
		Recovery time	sec	≤5			≤6						≤5		≤6		
		Fluctuation of revolution	rpm	≤15			≤25						≤30				
L.O. press.	Rated operation	MPa (kgf/cm <sup>2</sup> )	0.29±0.05 (3.0±0.5)						0.34±0.05 (3.5±0.5)								
	Idling		≥0.06 (≥0.6)														

\*1. Designation of engine dimension and dry weight in numerals.  
 CL/CH application: engine with flywheel housing  
 VM/VH application: engine with back plate/with flywheel housing

## 1-5 3TNE82A

\* Output conditions: Intake back pressure  $\leq 250$  mmAq, Exhaust back pressure  $\leq 550$  mmAq, other conditions complying with JIS D 1005-1986. After minimum 30 hour's run-in.

Item		Model	3TNE82A								
		Unit									
Application		—	CL				VM				
Type		—	Vertical, 4-cycle water-cooled diesel engine								
Combustion system		—	Direct injection system								
No. of cylinders – Bore $\times$ Stroke		mm	3 – 82 $\times$ 84								
Displacement		$\ell$	1.330								
Firing order		—	1 – 3 – 2 – 1								
Revolution speed		rpm	1500	1800	2000	2200	2400	2600	2800	3000	
Output*	Continuous rating	kW(HP)	9.9 (13.3)	12.0 (16.1)	—	—	—	—	—	—	
	Max. rating	kW(HP)	11.0 (14.8)	13.2 (17.7)	14.6 (19.6)	16.0 (21.5)	17.5 (23.5)	19.0 (25.5)	20.5 (27.5)	21.9 (29.4)	
Max. revolution speed at no load		rpm	1575 <sup>+50</sup> <sub>0</sub>	1870 <sup>+50</sup> <sub>0</sub>	2180 <sup>+50</sup> <sub>0</sub>	2375 <sup>+50</sup> <sub>0</sub>	2570 <sup>+50</sup> <sub>0</sub>	2780 <sup>+50</sup> <sub>0</sub>	2970 <sup>+50</sup> <sub>0</sub>	3180 <sup>+50</sup> <sub>0</sub>	
Min. revolution speed at no load			$\leq 1200$	$\leq 800$							
Direction of rotation		—	Counterclockwise (viewed from flywheel)								
Power take off		—	Flywheel								
Compression ratio		—	18.0								
Fuel injection timing (FID, b.T.D.C.)		deg	10 $\pm$ 1		12 $\pm$ 1		14 $\pm$ 1		16 $\pm$ 1		
Compression pressure		MPa (kgf/cm <sup>2</sup> )	3.04 $\pm$ 0.1 (31 $\pm$ 1), at 250 rpm								
Fuel injection pressure		MPa (kgf/cm <sup>2</sup> )	19.6 <sup>+1.0</sup> <sub>0</sub> (200 <sup>+10</sup> <sub>0</sub> )								
Recommended diesel gas oil		—	ISO 8217 DMA, BS 2869 A1 or A2 (Cetane No. 45 min.)								
Lubrication system		—	Forced lubrication with trochoid pump								
Lubricating oil capacity Max/Effective		$\ell$	3.6/1.3				5.0/1.7				
Recommended lubricating oil		—	API grade CC class or higher								
Cooling system		—	Liquid cooling/Radiator								
Cooling water capacity		$\ell$	1.8 (for engine only)								
Cooling fan No. of blade $\times$ dia.		mm	Pusher type, 6 $\times$ $\phi$ 335								
Crank V-pulley dia./ Fan V-pulley dia.		mm	$\phi$ 120/ $\phi$ 90				$\phi$ 110/ $\phi$ 110				
Governor		—	Mechanical centrifugal governor (All speed type)								
Starting system		—	Electrical								
*1 Dimensions L $\times$ W $\times$ H		mm	553 $\times$ 489 $\times$ 565				520.5 $\times$ 489 $\times$ 565 / 528 $\times$ 489 $\times$ 565				
*1 Dry weight		kg	138				112/128				
PERFORMANCE	Governing performance (full speed range)	Transient speed difference	%	$\leq 10$	$\leq 8$	$\leq 12$					
		Steady state speed band	%	$\leq 5$	$\leq 4$	$\leq 9$	$\leq 8$	$\leq 7$	$\leq 6$		
		Recovery time	sec	$\leq 5$				$\leq 6$			
		Fluctuation of revolution	rpm	$\leq 15$				$\leq 25$			
L.O. press.	Rated operation	MPa (kgf/cm <sup>2</sup> )	0.25 $\pm$ 0.05 (2.5 $\pm$ 0.5)	0.29 $\pm$ 0.05 (3.0 $\pm$ 0.5)							
	Idling		$\geq 0.06$ ( $\geq 0.6$ )								

\*1. Designation of engine dimension and dry weight in numerals.

CL/CH application: engine with flywheel housing

VM/VH application: engine with back plate/with flywheel housing

1-6 3TNE82

\* Output conditions: Intake back pressure ≤ 250 mmAq, Exhaust back pressure ≤ 550 mmAq, other conditions complying with JIS D 1005-1986. After minimum 30 hour's run-in.

Item		Model	3TNE82												
		Unit	CL	VM						CH	VH				
Application		—	CL	VM						CH	VH				
Type		—	Vertical, 4-cycle water-cooled diesel engine												
Combustion system		—	Direct injection system												
No. of cylinders – Bore × Stroke		mm	3 – 82 × 90												
Displacement		ℓ	1.425												
Firing order		—	1 – 3 – 2 – 1												
Revolution speed		rpm	1500	1800	2000	2200	2400	2600	2800	3000	3000	3600	3200	3400	3600
Output*	Continuous rating	kW(HP)	10.5 (14.1)	12.7 (17.0)	—	—	—	—	—	—	21.0 (28.2)	24.4 (32.7)	—	—	—
	Max. rating	kW(HP)	11.6 (15.6)	14.0 (18.8)	15.5 (20.8)	16.9 (22.7)	18.4 (24.7)	19.9 (26.7)	21.3 (28.6)	23.2 (31.1)	23.2 (31.1)	26.9 (36.1)	24.4 (32.7)	25.6 (34.3)	26.9 (36.1)
Max. revolution speed at no load		rpm	1570 <sup>+50</sup> <sub>0</sub>	1870 <sup>+50</sup> <sub>0</sub>	2160 <sup>+50</sup> <sub>0</sub>	2375 <sup>+50</sup> <sub>0</sub>	2570 <sup>+50</sup> <sub>0</sub>	2780 <sup>+50</sup> <sub>0</sub>	2970 <sup>+50</sup> <sub>0</sub>	3180 <sup>+50</sup> <sub>0</sub>	3150 <sup>+50</sup> <sub>0</sub>	3745 <sup>+50</sup> <sub>0</sub>	3455 <sup>+50</sup> <sub>0</sub>	3670 <sup>+50</sup> <sub>0</sub>	3890 <sup>+50</sup> <sub>0</sub>
Min. revolution speed at no load			≤1200	≤800						≤1500		≤800			
Direction of rotation		—	Counterclockwise (viewed from flywheel)												
Power take off		—	Flywheel												
Compression ratio		—	18.0												
Fuel injection timing (FID, b.T.D.C.)		deg	10±1	12±1		14±1		16±1		24±1		18±1	20±1	24±1	
Compression pressure		MPa (kgf/cm <sup>2</sup> )	3.04 ± 0.1 (31 ± 1), at 250 rpm												
Fuel injection pressure		MPa (kgf/cm <sup>2</sup> )	19.6 <sup>+1.0</sup> <sub>0</sub> (200 <sup>+10</sup> <sub>0</sub> )												
Recommended diesel gas oil		—	ISO 8217 DMA, BS 2869 A1 or A2 (Cetane No. 45 min.)												
Lubrication system		—	Forced lubrication with trochoid pump												
Lubricating oil capacity Max/Effective		ℓ	4.7/1.8						6.9/2.1						
Recommended lubricating oil		—	API grade CC class or higher												
Cooling system		—	Liquid cooling/Radiator												
Cooling water capacity		ℓ	2.0 (for engine only)												
Cooling fan No. of blade × dia.		mm	Pusher type, 6 × φ335												
Crank V-pulley dia./ Fan V-pulley dia.		mm	φ120/φ90		φ110/φ110										
Governor		—	Mechanical centrifugal governor (All speed type)												
Starting system		—	Electrical												
*1 Dimensions L × W × H		mm	589×486×623		556 × 486 × 623 / 564 × 486 × 623				564 × 486 × 623		556 × 486 × 623 / 564 × 486 × 623				
*1 Dry weight		kg	161		138/155				149		138/149				
PERFORMANCE	Governing performance (full speed range)	Transient speed difference	%	≤10	≤8	≤12						≤10	≤8	≤12	
		Steady state speed band	%	≤5	≤4	≤8	≤7	≤6		≤5	≤4	≤8			
		Recovery time	sec	≤5		≤6						≤5		≤6	
		Fluctuation of revolution	rpm	≤15		≤25						≤30			
L.O. press.	Rated operation	MPa (kgf/cm <sup>2</sup> )	0.29±0.05 (3.0±0.5)		0.34±0.05 (3.5±0.5)										
	Idling		≥0.06 (≥0.6)												

\*1. Designation of engine dimension and dry weight in numerals.  
 CL/CH application: engine with flywheel housing  
 VM/VH application: engine with back plate/with flywheel housing

## 1-7 3TNE84

\* Output conditions: Intake back pressure  $\leq 250$  mmAq, Exhaust back pressure  $\leq 550$  mmAq, other conditions complying with JIS D 1005-1986. After minimum 30 hour's run-in.

Item		Model		3TNE84												
		Unit	CL	VM						CH	VH					
Application		—	CL	VM						CH	VH					
Type		—	Vertical, 4-cycle water-cooled diesel engine													
Combustion system		—	Direct injection system													
No. of cylinders – Bore $\times$ Stroke		mm	3 – 84 $\times$ 90													
Displacement		$\ell$	1.496													
Firing order		—	1 – 3 – 2 – 1													
Revolution speed		rpm	1500	1800	2000	2200	2400	2600	2800	3000	3000	3600	3200	3400	3600	
Output*	Continuous rating	kW(HP)	11.3 (15.2)	13.5 (18.1)	—	—	—	—	—	—	22.4 (30.0)	26.1 (35.0)	—	—	—	
	Max. rating	kW(HP)	12.4 (16.6)	14.8 (19.8)	16.4 (22.0)	18.1 (24.3)	19.7 (26.4)	21.3 (28.6)	23.0 (30.8)	24.6 (33.0)	24.6 (33.0)	28.7 (38.5)	25.6 (34.3)	27.0 (36.2)	28.3 (38.0)	
Max. revolution speed at no load		rpm	1600 <sup>+50</sup> <sub>0</sub>	1900 <sup>+50</sup> <sub>0</sub>	2175 <sup>+50</sup> <sub>0</sub>	2375 <sup>+50</sup> <sub>0</sub>	2600 <sup>+50</sup> <sub>0</sub>	2800 <sup>+50</sup> <sub>0</sub>	3000 <sup>+50</sup> <sub>0</sub>	3225 <sup>+50</sup> <sub>0</sub>	3200 <sup>+50</sup> <sub>0</sub>	3800 <sup>+50</sup> <sub>0</sub>	3455 <sup>+50</sup> <sub>0</sub>	3670 <sup>+50</sup> <sub>0</sub>	3870 <sup>+50</sup> <sub>0</sub>	
Min. revolution speed at no load			$\leq 1200$	$\leq 800$						$\leq 1500$		$\leq 800$				
Direction of rotation		—	Counterclockwise (viewed from flywheel)													
Power take off		—	Flywheel													
Compression ratio		—	18.0													
Fuel injection timing (FID, b.T.D.C.)		deg	10 $\pm$ 1	12 $\pm$ 1	14 $\pm$ 1	16 $\pm$ 1	24 $\pm$ 1	18 $\pm$ 1	20 $\pm$ 1	24 $\pm$ 1						
Compression pressure		MPa (kgf/cm <sup>2</sup> )	3.24 $\pm$ 0.1 (33 $\pm$ 1), at 250 rpm													
Fuel injection pressure		MPa (kgf/cm <sup>2</sup> )	19.6 <sup>+1.0</sup> <sub>0</sub> (200 <sup>+10</sup> <sub>0</sub> )													
Recommended diesel gas oil		—	ISO 8217 DMA, BS 2869 A1 or A2 (Cetane No. 45 min.)													
Lubrication system		—	Forced lubrication with trochoid pump													
Lubricating oil capacity Max/Effective		$\ell$	4.7/1.8						6.9/2.1							
Recommended lubricating oil		—	API grade CC class or higher													
Cooling system		—	Liquid cooling/Radiator													
Cooling water capacity		$\ell$	2.0 (for engine only)													
Cooling fan No. of blade $\times$ dia.		mm	Pusher type, 6 $\times$ $\phi$ 335													
Crank V-pulley dia./ Fan V-pulley dia.		mm	$\phi$ 120/ $\phi$ 90	$\phi$ 110/ $\phi$ 110												
Governor		—	Mechanical centrifugal governor (All speed type)													
Starting system		—	Electrical													
*1 Dimensions L $\times$ W $\times$ H		mm	589 $\times$ 486 $\times$ 623	556 $\times$ 486 $\times$ 623 / 564 $\times$ 486 $\times$ 623						564 $\times$ 486 $\times$ 623	556 $\times$ 486 $\times$ 623 / 564 $\times$ 486 $\times$ 623					
*1 Dry weight		kg	161	138/155						149	138 / 149					
PERFORMANCE	Governing performance (full speed range)	Transient speed difference	%	$\leq 10$	$\leq 8$	$\leq 12$						$\leq 10$	$\leq 8$	$\leq 12$		
		Steady state speed band	%	$\leq 5$	$\leq 4$	$\leq 9$	$\leq 8$	$\leq 7$	$\leq 5$	$\leq 4$	$\leq 8$					
		Recovery time	sec	$\leq 5$		$\leq 6$						$\leq 5$		$\leq 6$		
		Fluctuation of revolution	rpm	$\leq 15$		$\leq 25$						$\leq 30$				
L.O. press.	Rated operation	MPa (kgf/cm <sup>2</sup> )	0.29 $\pm$ 0.05 (3.0 $\pm$ 0.5)		0.34 $\pm$ 0.05 (3.5 $\pm$ 0.5)						0.39 $\pm$ 0.05 (4.0 $\pm$ 0.5)					
	Idling		$\geq 0.06$ ( $\geq 0.6$ )													

\*1. Designation of engine dimension and dry weight in numerals.

CL/CH application: engine with flywheel housing

VM/VH application: engine with back plate/with flywheel housing

1-8 3TNE88

\* Output conditions: Intake back pressure ≤ 250 mmAq, Exhaust back pressure ≤ 550 mmAq, other conditions complying with JIS D 1005-1986. After minimum 30 hour's run-in.

Item		Model	3TNE88								
		Unit									
Application		—	CL				VM				
Type		—	Vertical, 4-cycle water-cooled diesel engine								
Combustion system		—	Direct injection system								
No. of cylinders – Bore × Stroke		mm	3 – 88 × 90								
Displacement		ℓ	1.642								
Firing order		—	1 – 3 – 2 – 1								
Revolution speed		rpm	1500	1800	2000	2200	2400	2600	2800	3000	
Output*	Continuous rating	kW(HP)	12.3 (16.5)	14.8 (19.8)	—	—	—	—	—	—	
	Max. rating	kW(HP)	13.5 (18.1)	16.3 (21.9)	18.0 (24.1)	19.9 (26.7)	21.6 (29.0)	23.5 (31.5)	25.2 (33.8)	27.1 (36.3)	
Max. revolution speed at no load		rpm	1600 <sup>+50</sup> <sub>0</sub>	1900 <sup>+50</sup> <sub>0</sub>	2175 <sup>+50</sup> <sub>0</sub>	2375 <sup>+50</sup> <sub>0</sub>	2600 <sup>+50</sup> <sub>0</sub>	2800 <sup>+50</sup> <sub>0</sub>	3000 <sup>+50</sup> <sub>0</sub>	3225 <sup>+50</sup> <sub>0</sub>	
Min. revolution speed at no load			≤1200	≤800							
Direction of rotation		—	Counterclockwise (viewed from flywheel)								
Power take off		—	Flywheel								
Compression ratio		—	18.0								
Fuel injection timing (FID, b.T.D.C.)		deg	10±1		12±1		14±1		16±1		
Compression pressure		MPa (kgf/cm <sup>2</sup> )	3.43 ± 0.1 (35 ± 1), at 250 rpm								
Fuel injection pressure		MPa (kgf/cm <sup>2</sup> )	19.6 <sup>+1.0</sup> <sub>0</sub> (200 <sup>+10</sup> <sub>0</sub> )								
Recommended diesel gas oil		—	ISO 8217 DMA, BS 2869 A1 or A2 (Cetane No. 45 min.)								
Lubrication system		—	Forced lubrication with trochoid pump								
Lubricating oil capacity Max/Effective		ℓ	4.7/1.8						6.9/2.1		
Recommended lubricating oil		—	API grade CC class or higher								
Cooling system		—	Liquid cooling/Radiator								
Cooling water capacity		ℓ	2.0 (for engine only)								
Cooling fan No. of blade × dia.		mm	Pusher type, 6 × φ335								
Crank V-pulley dia./ Fan V-pulley dia.		mm	φ120/φ90			φ110/φ110					
Governor		—	Mechanical centrifugal governor (All speed type)								
Starting system		—	Electrical								
*1 Dimensions L × W × H		mm	589 × 486 × 623			556 × 486 × 623 / 564 × 486 × 623					
*1 Dry weight		kg	161			138/155					
PERFORMANCE	Governing performance (full speed range)	Transient speed difference	%	≤10	≤8	≤12					
		Steady state speed band	%	≤5	≤4	≤9	≤8	≤7			
		Recovery time	sec	≤5			≤6				
		Fluctuation of revolution	rpm	≤15			≤25				
L.O. press.	Rated operation	MPa (kgf/cm <sup>2</sup> )	0.29 ± 0.05 (3.0 ± 0.5)	0.34 ± 0.05 (3.5 ± 0.5)							
	Idling		≥0.06 (≥0.6)								

\*1. Designation of engine dimension and dry weight in numerals.  
 CL/CH application: engine with flywheel housing  
 VM/VH application: engine with back plate/with flywheel housing

## 1-9 4TNE82

\* Output conditions: Intake back pressure ≤ 250 mmAq, Exhaust back pressure ≤ 550 mmAq, other conditions complying with JIS D 1005-1986. After minimum 30 hour's run-in.

Item	Model		4TNE82														
	Unit		CL	VM						CH	VH						
Application	—		CL	VM						CH	VH						
Type	—		Vertical, 4-cycle water-cooled diesel engine														
Combustion system	—		Direct injection system														
No. of cylinders – Bore × Stroke	mm		4 – 82 × 90														
Displacement	ℓ		1.901														
Firing order	—		1 – 3 – 4 – 2 – 1														
Revolution speed	rpm		1500	1800	2000	2200	2400	2600	2800	3000	3000	3600	3200	3400	3600		
Output*	Continuous rating	kW(HP)	14.3 (19.2)	17.1 (22.9)	—	—	—	—	—	—	27.7 (37.1)	32.7 (43.9)	—	—	—		
	Max. rating	kW(HP)	15.7 (21.1)	18.8 (25.2)	20.6 (27.6)	22.6 (30.3)	24.5 (32.9)	26.5 (35.5)	28.5 (38.2)	30.5 (40.9)	30.5 (40.9)	36.0 (48.3)	32.4 (43.4)	34.2 (45.9)	36.0 (48.3)		
Max. revolution speed at no load	rpm		1575 <sup>+50</sup> <sub>0</sub>	1870 <sup>+50</sup> <sub>0</sub>	2160 <sup>+50</sup> <sub>0</sub>	2375 <sup>+50</sup> <sub>0</sub>	2570 <sup>+50</sup> <sub>0</sub>	2780 <sup>+50</sup> <sub>0</sub>	2970 <sup>+50</sup> <sub>0</sub>	3180 <sup>+50</sup> <sub>0</sub>	3150 <sup>+50</sup> <sub>0</sub>	3745 <sup>+50</sup> <sub>0</sub>	3455 <sup>+50</sup> <sub>0</sub>	3670 <sup>+50</sup> <sub>0</sub>	3890 <sup>+50</sup> <sub>0</sub>		
Min. revolution speed at no load	rpm		≤1200			≤800				≤1500			≤800				
Direction of rotation	—		Counterclockwise (viewed from flywheel)														
Power take off	—		Flywheel														
Compression ratio	—		18.0														
Fuel injection timing (FID, b.T.D.C.)	deg		10±1	12±1	14±1	16±1	24±1	18±1	20±1	24±1							
Compression pressure	MPa (kgf/cm <sup>2</sup> )		3.04±0.1 (31±1), at 250 rpm														
Fuel injection pressure	MPa (kgf/cm <sup>2</sup> )		19.6 <sup>+1.0</sup> <sub>0</sub> (200 <sup>+10</sup> <sub>0</sub> )														
Recommended diesel gas oil	—		ISO 8217 DMA, BS 2869 A1 or A2 (Cetane No. 45 min.)														
Lubrication system	—		Forced lubrication with trochoid pump														
Lubricating oil capacity Max/Effective	ℓ		5.8/2.3						7.9/2.5								
Recommended lubricating oil	—		API grade CC class or higher														
Cooling system	—		Liquid cooling/Radiator														
Cooling water capacity	ℓ		2.7 (for engine only)														
Cooling fan No. of blade × dia.	mm		Pusher type, 6 × φ370														
Crank V-pulley dia./ Fan V-pulley dia.	mm		φ120/φ90			φ110/φ110											
Governor	—		Mechanical centrifugal governor (All speed type)														
Starting system	—		Electrical														
*1 Dimensions L × W × H	mm		683 × 498.5 × 618			632 × 448.5 × 618 / 658 × 498.5 × 618						658 × 498.5 × 618		650 × 498.5 × 618 / 658 × 498 × 618			
*1 Dry weight	kg		184			160/170						170		160/170			
PERFORMANCE	Governing performance (full speed range)	Transient speed difference	%	≤10	≤8	≤12						≤10	≤8	≤12			
		Steady state speed band	%	≤5	≤4	≤8	≤7	≤6	≤5	≤4	≤8						
		Recovery time	sec	≤5			≤6						≤5		≤6		
		Fluctuation of revolution	rpm	≤15			≤25						≤30				
L.O. press.	Rated operation	MPa (kgf/cm <sup>2</sup> )	0.29±0.05 (3.0±0.5)			0.34±0.05 (3.5±0.5)											
	Idling		≥0.06 (≥0.6)														

\*1. Designation of engine dimension and dry weight in numerals.

CL/CH application: engine with flywheel housing

VM/VH application: engine with back plate/with flywheel housing

1-10. 4TNE84

\* Output conditions: Intake back pressure ≤ 250 mmAq, Exhaust back pressure ≤ 550 mmAq, other conditions complying with JIS D 1005-1986. After minimum 30 hour's run-in.

Item		Model	4TNE84												
		Unit	CL	VM					CH	VH					
Application		—	CL	VM					CH	VH					
Type		—	Vertical, 4-cycle water-cooled diesel engine												
Combustion system		—	Direct injection system												
No. of cylinders – Bore × Stroke		mm	4 – 84 × 90												
Displacement		<i>e</i>	1.995												
Firing order		—	1 – 3 – 4 – 2 – 1												
Revolution speed		rpm	1500	1800	2000	2200	2400	2600	2800	3000	3000	3600	3200	3400	3600
Output*	Continuous rating	kW(HP)	14.9 (20.0)	17.7 (23.7)	—	—	—	—	—	—	29.9 (40.1)	34.7 (46.5)	—	—	—
	Max. rating	kW(HP)	16.4 (22.0)	19.5 (26.1)	21.9 (29.4)	24.1 (32.3)	26.3 (35.3)	28.5 (38.2)	30.7 (41.2)	32.9 (44.1)	32.9 (44.1)	38.2 (51.2)	33.9 (45.5)	35.8 (48.0)	38.2 (51.2)
Max. revolution speed at no load		rpm	1575 <sup>+50</sup> <sub>0</sub>	1870 <sup>+50</sup> <sub>0</sub>	2180 <sup>+50</sup> <sub>0</sub>	2400 <sup>+50</sup> <sub>0</sub>	2590 <sup>+50</sup> <sub>0</sub>	2810 <sup>+50</sup> <sub>0</sub>	2995 <sup>+50</sup> <sub>0</sub>	3210 <sup>+50</sup> <sub>0</sub>	3150 <sup>+50</sup> <sub>0</sub>	3745 <sup>+50</sup> <sub>0</sub>	3455 <sup>+50</sup> <sub>0</sub>	3670 <sup>+50</sup> <sub>0</sub>	3890 <sup>+50</sup> <sub>0</sub>
Min. revolution speed at no load			≤1200	≤800					≤1500	≤800					
Direction of rotation		—	Counterclockwise (viewed from flywheel)												
Power take off		—	Flywheel												
Compression ratio		—	18.0												
Fuel injection timing (FID, b.T.D.C.)		deg	10±1	12±1	14±1	16±1	24±1	18±1	20±1	24±1					
Compression pressure		MPa (kgf/cm <sup>2</sup> )	3.24±0.1 (33±1), at 250 rpm												
Fuel injection pressure		MPa (kgf/cm <sup>2</sup> )	19.6 <sup>+1.0</sup> <sub>0</sub> (200 <sup>+10</sup> <sub>0</sub> )					19.6 <sup>+1.0</sup> <sub>0</sub> (200 <sup>+10</sup> <sub>0</sub> )							
Recommended diesel gas oil		—	ISO 8217 DMA, BS 2869 A1 or A2 (Cetane No. 45 min.)												
Lubrication system		—	Forced lubrication with trochoid pump												
Lubricating oil capacity Max/Effective		<i>e</i>	5.8/2.3					7.9/2.5							
Recommended lubricating oil		—	API grade CC class or higher												
Cooling system		—	Liquid cooling/Radiator												
Cooling water capacity		<i>e</i>	2.7 (for engine only)												
Cooling fan No. of blade × dia.		mm	Pusher type, 6 × φ370												
Crank V-pulley dia./ Fan V-pulley dia.		mm	φ120/φ90	φ110/φ110											
Governor		—	Mechanical centrifugal governor (All speed type)												
Starting system		—	Electrical												
*1 Dimensions L × W × H		mm	683 × 498.5 × 618	632 × 498.5 × 618/658 × 498.5 × 618					658 × 498.5 × 618	650 × 498.5 × 618/658 × 498.5 × 618					
*1 Dry weight		kg	184	160/170					170	160 / 170					
PERFORMANCE	Governing performance (full speed range)	Transient speed difference	%	≤10	≤8	≤12					≤10	≤8	≤12		
		Steady state speed band	%	≤5	≤4	≤9	≤8	≤7	≤5	≤4	≤8				
		Recovery time	sec	≤5		≤6					≤5		≤6		
		Fluctuation of revolution	rpm	≤15		≤25					≤30				
L.O. press.	Rated operation	MPa (kgf/cm <sup>2</sup> )	0.29±0.05 (3.0±0.5)		0.34±0.05 (3.5±0.5)										
	Idling		≥0.06 (≥0.6)												

\*1. Designation of engine dimension and dry weight in numerals.  
 CL/CH application: engine with flywheel housing  
 VM/VH application: engine with back plate/with flywheel housing



## 1-11. 4TNE88

\* Output conditions: Intake back pressure  $\leq 250$  mmAq, Exhaust back pressure  $\leq 550$  mmAq, other conditions complying with JIS D 1005-1986. After minimum 30 hour's run-in.

Item		Model		4TNE88						
		Unit								
Application		—	CL			VM				
Type		—	Vertical, 4-cycle water-cooled diesel engine							
Combustion system		—	Direct injection system							
No. of cylinders – Bore $\times$ Stroke		mm	4 – 88 $\times$ 90							
Displacement		$\ell$	2.189							
Firing order		—	1 – 3 – 4 – 2 – 1							
Revolution speed		rpm	1500	1800	2000	2200	2400	2600	2800	3000
Output*	Continuous rating	kW(HP)	16.4 (22.0)	19.6 (26.3)	—	—	—	—	—	—
	Max. rating	kW(HP)	18.0 (24.1)	21.6 (29.0)	24.1 (32.3)	26.5 (35.5)	28.8 (38.6)	31.3 (42.0)	33.7 (45.2)	36.0 (48.3)
Max. revolution speed at no load		rpm	1575 <sup>+50</sup> <sub>0</sub>	1870 <sup>+50</sup> <sub>0</sub>	2180 <sup>+50</sup> <sub>0</sub>	2400 <sup>+50</sup> <sub>0</sub>	2590 <sup>+50</sup> <sub>0</sub>	2810 <sup>+50</sup> <sub>0</sub>	2995 <sup>+50</sup> <sub>0</sub>	3210 <sup>+50</sup> <sub>0</sub>
Min. revolution speed at no load			$\leq 1200$	$\leq 800$						
Direction of rotation		—	Counterclockwise (viewed from flywheel)							
Power take off		—	Flywheel							
Compression ratio		—	18.0							
Fuel injection timing (FID, b.T.D.C.)		deg	10 $\pm$ 1		12 $\pm$ 1		14 $\pm$ 1		16 $\pm$ 1	
Compression pressure		MPa (kgf/cm <sup>2</sup> )	3.43 $\pm$ 0.1 (35 $\pm$ 1), at 250 rpm							
Fuel injection pressure		MPa (kgf/cm <sup>2</sup> )	19.6 <sup>+1.0</sup> <sub>0</sub> (200 <sup>+10</sup> <sub>0</sub> )						19.6 <sup>+1.0</sup> <sub>0</sub> (200 <sup>+10</sup> <sub>0</sub> )	
Recommended diesel gas oil		—	ISO 8217 DMA, BS 2869 A1 or A2 (Cetane No. 45 min.)							
Lubrication system		—	Forced lubrication with trochoid pump							
Lubricating oil capacity Max/Effective		$\ell$	5.8/2.3						7.9/2.5	
Recommended lubricating oil		—	API grade CC class or higher							
Cooling system		—	Liquid cooling/Radiator							
Cooling water capacity		$\ell$	2.7 (for engine only)							
Cooling fan No. of blade $\times$ dia.		mm	Pusher type, 6 $\times$ $\phi$ 370							
Crank V-pulley dia./ Fan V-pulley dia.		mm	$\phi$ 120/ $\phi$ 90			$\phi$ 110/ $\phi$ 110				
Governor		—	Mechanical centrifugal governor (All speed type)							
Starting system		—	Electrical							
*1 Dimensions L $\times$ W $\times$ H		mm	683 $\times$ 498.5 $\times$ 618			632 $\times$ 498.5 $\times$ 618 / 658 $\times$ 498.5 $\times$ 618				
*1 Dry weight		kg	184			160 /170				
PERFORMANCE	Governing performance (full speed range)	Transient speed difference	%	$\leq 10$	$\leq 8$	$\leq 12$				
		Steady state speed band	%	$\leq 5$	$\leq 4$	$\leq 9$	$\leq 8$	$\leq 7$		
		Recovery time	sec	$\leq 5$			$\leq 6$			
		Fluctuation of revolution	rpm	$\leq 15$			$\leq 25$			
L.O. press.	Rated operation	MPa (kgf/cm <sup>2</sup> )	0.29 $\pm$ 0.05 (3.0 $\pm$ 0.5)		0.34 $\pm$ 0.05 (3.5 $\pm$ 0.5)					
	Idling		$\geq 0.06$ ( $\geq 0.6$ )							

\*1. Designation of engine dimension and dry weight in numerals.

CL/CH application: engine with flywheel housing

VM/VH application: engine with back plate/with flywheel housing

1-12. 3TNE84T

\* Output conditions: Intake back pressure ≤ 250 mmAq, Exhaust back pressure ≤ 550 mmAq, other conditions complying with JIS D 1005-1986. After minimum 30 hour's run-in.

Item		Model	3TNE84T												
		Unit	CL	VM				CH	VH						
Application		—	CL	VM				CH	VH						
Type		—	Vertical, 4-cycle water-cooled diesel engine												
Combustion system		—	Direct injection system												
No. of cylinders – Bore × Stroke		mm	3 – 84 × 90												
Displacement		ℓ	1.496												
Firing order		—	1 – 3 – 2 – 1												
Revolution speed		rpm	1500	1800	2000	2200	2400	2600	2800	3000	3000	3600	3200	3400	3600
Output*	Continuous rating	kW(HP)	14.0 (18.8)	16.6 (22.3)	—	—	—	—	—	—	28.0 (37.5)	30.5 (40.9)	—	—	—
	Max. rating	kW(HP)	15.8 (21.2)	18.8 (25.2)	21.0 (28.2)	22.8 (30.6)	25.0 (33.5)	26.9 (36.1)	29.1 (39.0)	30.9 (41.4)	30.9 (41.4)	34.2 (45.9)	32.0 (42.9)	33.1 (44.4)	34.2 (45.9)
Max. revolution speed at no load		rpm	1600 <sup>+50</sup> <sub>0</sub>	1900 <sup>+50</sup> <sub>0</sub>	2175 <sup>+50</sup> <sub>0</sub>	2375 <sup>+50</sup> <sub>0</sub>	2600 <sup>+50</sup> <sub>0</sub>	2800 <sup>+50</sup> <sub>0</sub>	3020 <sup>+50</sup> <sub>0</sub>	3240 <sup>+50</sup> <sub>0</sub>	—	—	—	—	—
Min. revolution speed at no load			1200 <sup>+50</sup> <sub>0</sub>	≤800 <sup>+50</sup> <sub>0</sub>				—				—			
Direction of rotation		—	Counterclockwise (viewed from flywheel)												
Power take off		—	Flywheel												
Compression ratio		—	18.0												
Fuel injection timing (FID, b.T.D.C.)		deg	10±1	12±1	14±1	16±1	—	—	—	—	—	—	—	—	—
Compression pressure		MPa (kgf/cm <sup>2</sup> )	2.94 ± 0.1 (30 ± 1), at 250 rpm												
Fuel injection pressure		MPa (kgf/cm <sup>2</sup> )	19.6 <sup>+1.0</sup> <sub>0</sub> (200 <sup>+10</sup> <sub>0</sub> )												
Recommended diesel gas oil		—	ISO 8217 DMA, BS 2869 A1 or A2 (Cetane No. 45 min.)												
Lubrication system		—	Forced lubrication with trochoid pump												
Lubricating oil capacity Max/Effective		ℓ	4.8 / 1.9				—				—				
Recommended lubricating oil		—	API grade CC class or higher												
Cooling system		—	Liquid cooling/Radiator												
Cooling water capacity		ℓ	2.0 (for engine only)												
Cooling fan No. of blade × dia.		mm	Pusher type, 6 × φ335												
Crank V-pulley dia./ Fan V-pulley dia.		mm	φ110/φ90	φ110/φ110											
Governor		—	Mechanical centrifugal governor (All speed type)												
Starting system		—	Electrical												
*1 Dimensions L × W × H		mm	589×54.0×629		632 × 540 × 629 / 632 × 540 × 629				—		—				
*1 Dry weight		kg	166		147/160				—		—				
PERFORMANCE	Governing performance (full speed range)	Transient speed difference	%	≤10	≤8	≤12				—	—	—			
		Steady state speed band	%	≤5	≤4	≤9	≤8	≤8	—	—	—				
		Recovery time	sec	≤5		≤6				—		—			
		Fluctuation of revolution	rpm	≤15		≤22				—					
L.O. press.	Rated operation	MPa (kgf/cm <sup>2</sup> )	0.29±0.05 (3.0±0.5)		0.34±0.05(3.5±0.5)										
	Idling		≥0.06 (≥0.6)												

\*1. Designation of engine dimension and dry weight in numerals.  
 CL/CH application: engine with flywheel housing  
 VM/VH application: engine with back plate/with flywheel housing

1-13. 4TNE84T

\* Output conditions: Intake back pressure ≤ 250 mmAq, Exhaust back pressure ≤ 550 mmAq, other conditions complying with JIS D 1005-1986. After minimum 30 hour's run-in.

Item	Model		4TNE84T												
	Unit		CL	VM				CH	VH						
Application	—		CL	VM				CH	VH						
Type	—		Vertical, 4-cycle water-cooled diesel engine												
Combustion system	—		Direct injection system												
No. of cylinders - Bore × Stroke	mm		4 - 84 × 90												
Displacement	ℓ		1.995												
Firing order	—		1 - 3 - 4 - 2 - 1												
Revolution speed	rpm		1500	1800	2000	2200	2400	2600	2800	3000	3000	3600	3200	3400	3600
Output*	Continuous rating	kW(HP)	19.1 (25.6)	24.3 (32.6)	—	—	—	—	—	—	37.1 (49.8)	40.8 (54.7)	—	—	—
	Max. rating	kW(HP)	21.3 (28.6)	26.9 (36.1)	28.0 (37.5)	30.5 (40.9)	33.5 (44.9)	35.7 (47.9)	38.6 (51.8)	41.2 (55.3)	41.2 (55.3)	45.6 (61.2)	42.7 (57.3)	44.1 (59.1)	45.6 (61.2)
Max. revolution speed at no load	rpm		1600 <sup>+50</sup> <sub>0</sub>	1900 <sup>+50</sup> <sub>0</sub>	2175 <sup>+50</sup> <sub>0</sub>	2375 <sup>+50</sup> <sub>0</sub>	2600 <sup>+50</sup> <sub>0</sub>	2800 <sup>+50</sup> <sub>0</sub>	3000 <sup>+50</sup> <sub>0</sub>	3225 <sup>+50</sup> <sub>0</sub>	—	—	—	—	—
Min. revolution speed at no load			1200 <sup>+50</sup> <sub>0</sub>	800 <sup>+50</sup> <sub>0</sub>				—				—			
Direction of rotation	—		Counterclockwise (viewed from flywheel)												
Power take off	—		Flywheel												
Compression ratio	—		18.0												
Fuel injection timing (FID, b.T.D.C.)	deg		10±1	12±1	14±1	16±1	—	—	—	—	—	—	—	—	—
Compression pressure	MPa (kgf/cm <sup>2</sup> )		2.94±0.1 (30±1), at 250 rpm												
Fuel injection pressure	MPa (kgf/cm <sup>2</sup> )		19.6 <sup>+1.0</sup> <sub>0</sub> (200 <sup>+10</sup> <sub>0</sub> )				19.6 <sup>+1.0</sup> <sub>0</sub> (200 <sup>+10</sup> <sub>0</sub> )				—				
Recommended diesel gas oil	—		ISO 8217 DMA, BS 2869 A1 or A2 (Cetane No. 45 min.)												
Lubrication system	—		Forced lubrication with trochoid pump												
Lubricating oil capacity Max/Effective	ℓ		5.8/2.3				—				—				
Recommended lubricating oil	—		API grade CC class or higher												
Cooling system	—		Liquid cooling/Radiator												
Cooling water capacity	ℓ		2.7 (for engine only)												
Cooling fan No. of blade × dia.	mm		Discharge type, 6 × φ370												
Crank V-pulley dia./ Fan V-pulley dia.	mm		φ110/φ90	φ110/φ110											
Governor	—		Mechanical centrifugal governor (All speed type)												
Starting system	—		Electrical												
*1 Dimensions L × W × H	mm		674 × 498.5 × 713	641 × 498.5 × 713 / 649 × 498.5 × 713				—				—			
*1 Dry weight	kg		184	165 / 175				—				—			
PERFORMANCE	Governing performance (full speed range)	Transient speed difference	%	≤10	≤8	≤12				—		—		—	
		Steady state speed band	%	≤5	≤4	≤9	≤8	≤7	—		—		—		
		Recovery time	sec	≤5		≤6				—		—			
		Fluctuation of revolution	rpm	≤15		≤22				—					
L.O. press.	Rated operation	MPa (kgf/cm <sup>2</sup> )	0.29±0.05 (3.0±0.5)		0.34±0.05 (3.5±0.5)										
	Idling		≥0.06 (≥0.6)												

\*1. Designation of engine dimension and dry weight in numerals.  
 CL/CH application: engine with flywheel housing  
 VM/VH application: engine with back plate/with flywheel housing

## 2. Cross Sectional Views

### 2-1. Special Swirl Pre-combustion Chamber System (Indirect Injection System)

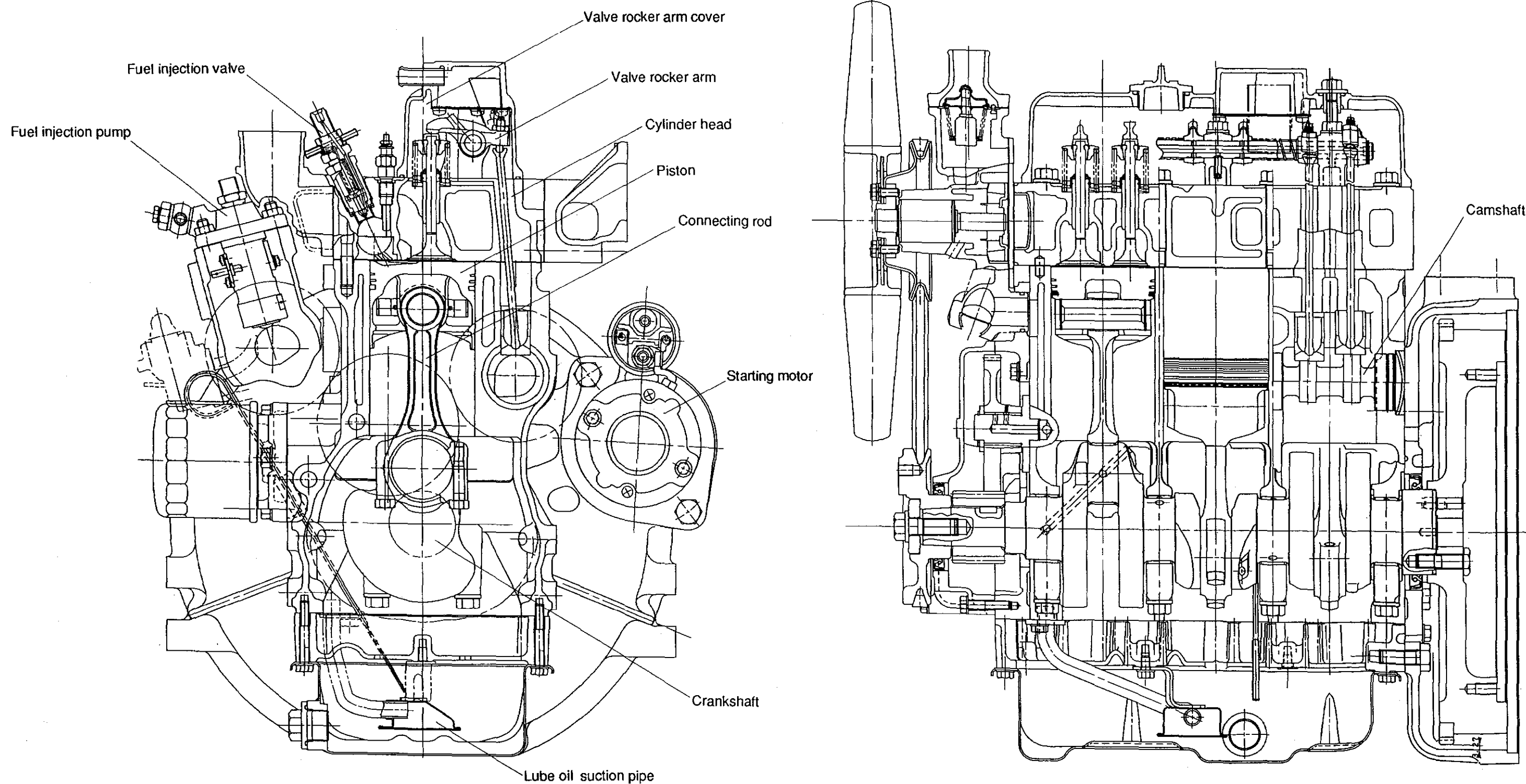

### 2-2. Direct Injection System

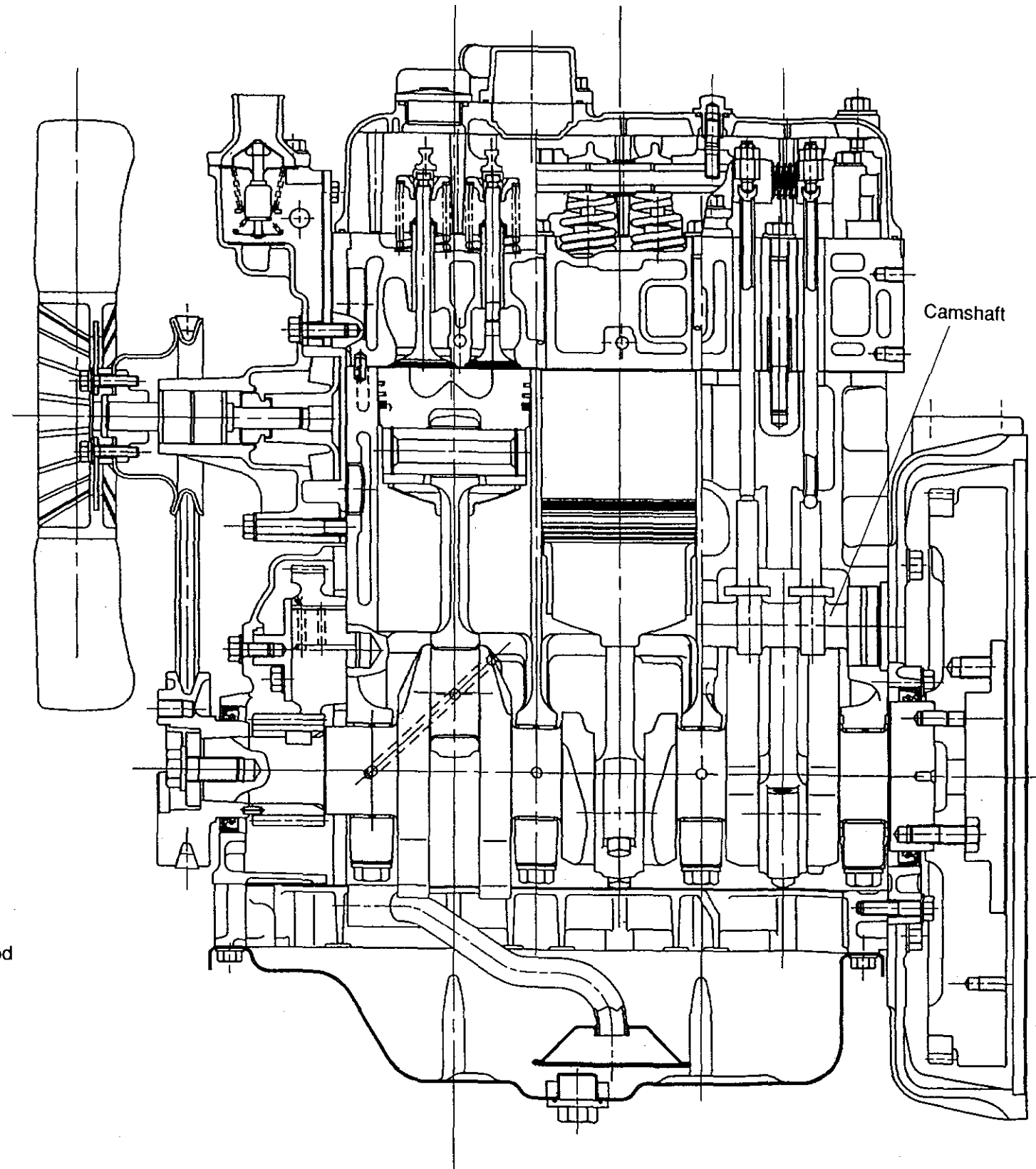
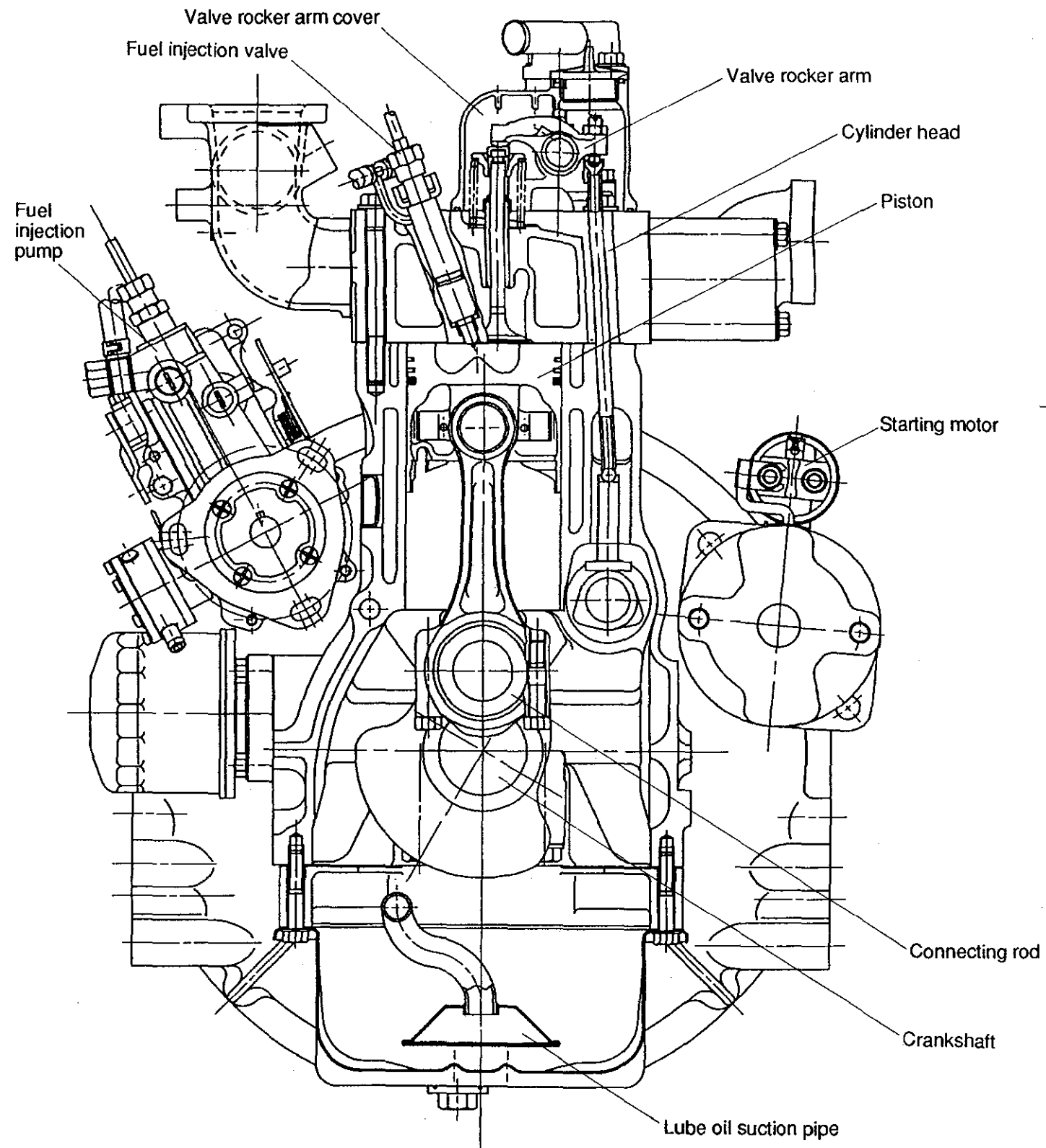

# 3. Cooling Water, Lubricating Oil and Fuel Oil

## 3-1. Cooling water

### 1. Proper use of cooling water

Impurities in cooling water are deposited in the engine and radiator in the form of scale and cause rusting. For this reason, heat conduction of the cooling system and cooling water flow are impaired, and cause cooling functions to reduce and the engine to over-heat. Therefore, drain the cooling water at intervals of 400 hours or one year. Never use hard water as the cooling water.

In order to prevent the cooling water from freezing in cold weather, be sure to use an antifreeze agent. For further information on and proper usage and type of rust-preventive agents, antifreezes, and cleaning agents, contact your nearest dealer.

### 2. Cooling water system diagram

Indirect injection system and direct injection system

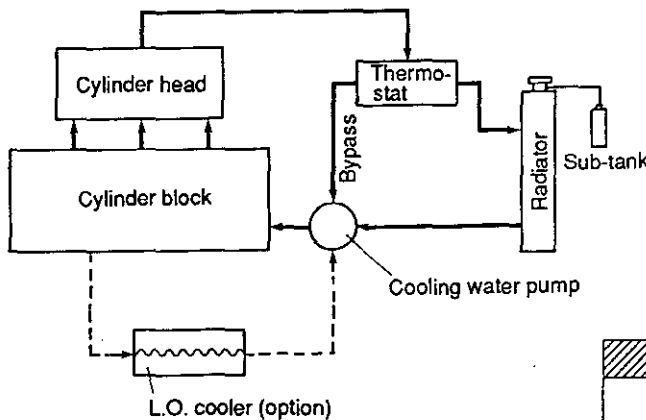

### 1. Proper use of lubricating oil

Use of proper lubricating oil brings about the following effects.

- (1) The friction part of the engine is protected from friction and wear.
- (2) The engine parts is protected from rusting and corrosion.
- (3) The high temperature part of the engine is effectively cooled.
- (4) The engine is protected from leakage of combustion gas.
- (5) The engine parts are protected from sludge deposits.

For the above reasons, use lubricating oil API Service Classification Class CC or better.

### Reference : Lubricating oil to be used at ambient temperature

Select the viscosity of lubricating oil depending on ambient temperature at which the engine is used, according to SAE Service Grade shown below.

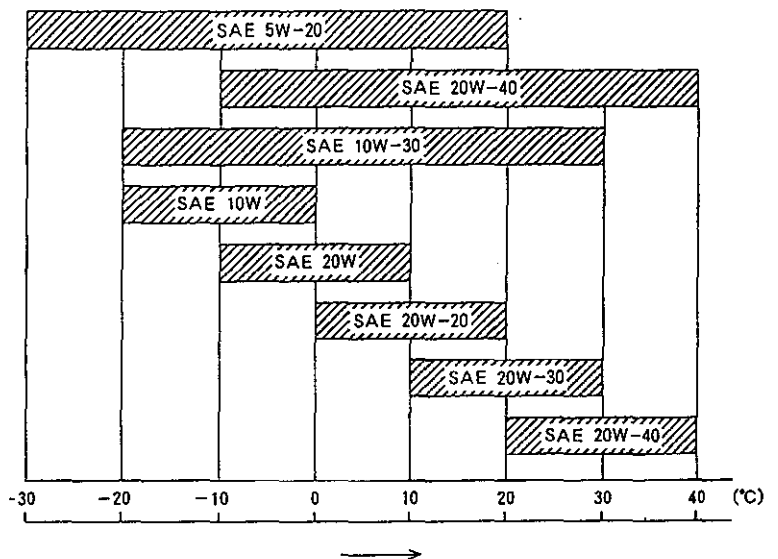

Ambient temperature at which the engine is used, °C

▨: Recommended SAE Service Grade

2. Lubrication system diagram

(1) Indirect Injection system

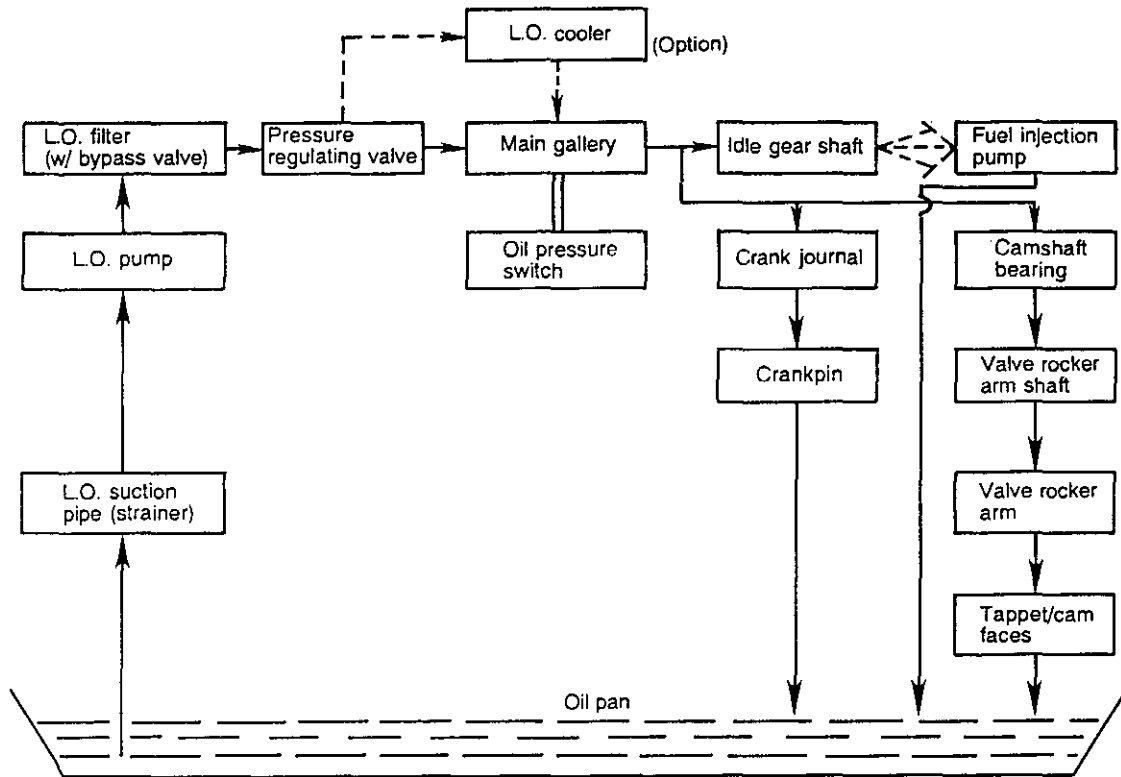

(2) Direct Injection system

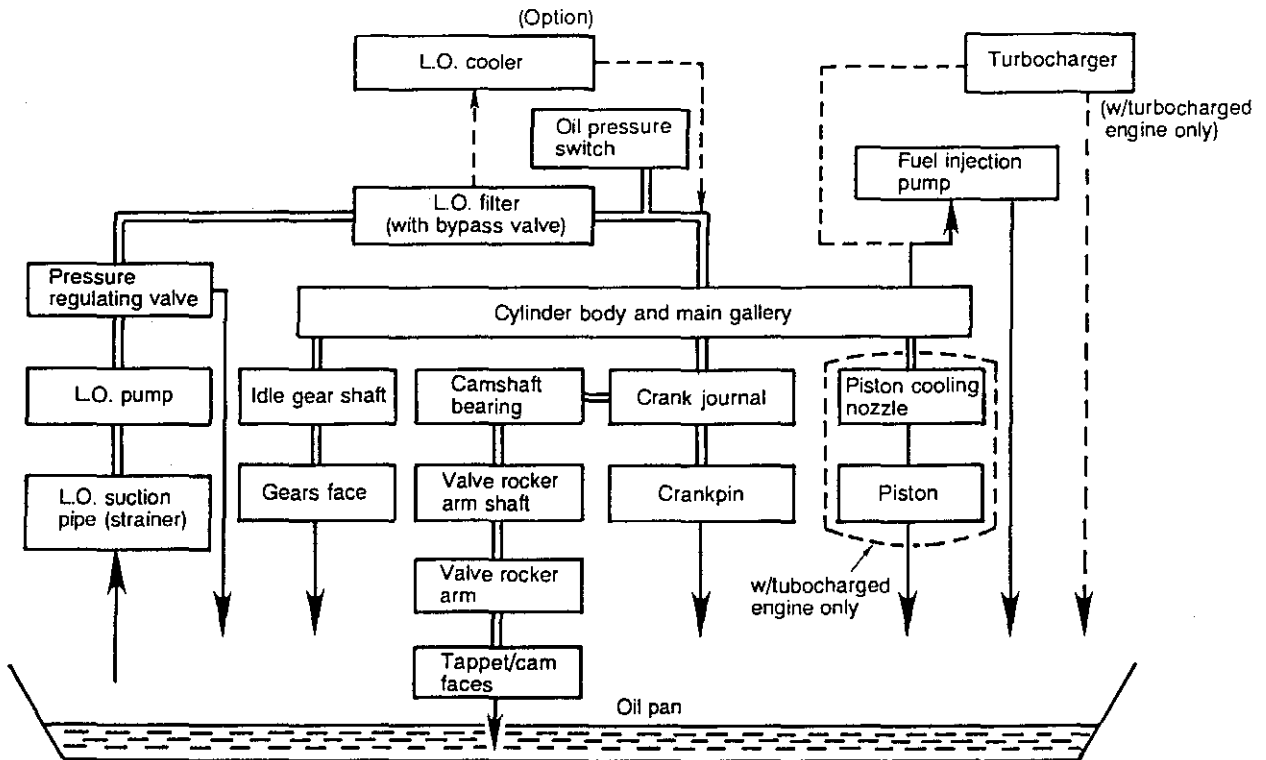

### 3-3. Fuel oil

#### 1. Proper use of diesel gas oil

Use a diesel gas oil equivalent to or better than ISO 8217 DMA, BS 2869 Part 1 class A1 or Part 2 class A2. (Cetane Number: 45 min.) Give your customers instructions on proper use of fuel oil, or the customers may suffer from troubles stated below.

##### (1) Deposits on the exhaust valve

Deposits on the exhaust valve cause unburnt oil mixture in exhaust gas and erosion of the exhaust valve seat, to occur in addition to poor compression, imperfect combustion, excessive fuel consumption, etc.

##### (2) Deposits in the piston ring groove

Deposits in the piston ring groove cause blow-by gas, poor lubrication, imperfect combustion, excessive fuel consumption, contamination of lubricating oil, premature wear, etc. of the cylinder liner and piston ring.

##### (3) Clogging or corrosion of nozzle hole in fuel injection valve

Imperfect combustion causes the fuel injection mechanism to wear and corrode and the nozzle to be clogged.

#### 2. Fuel system diagram

##### (1) Indirect injection system

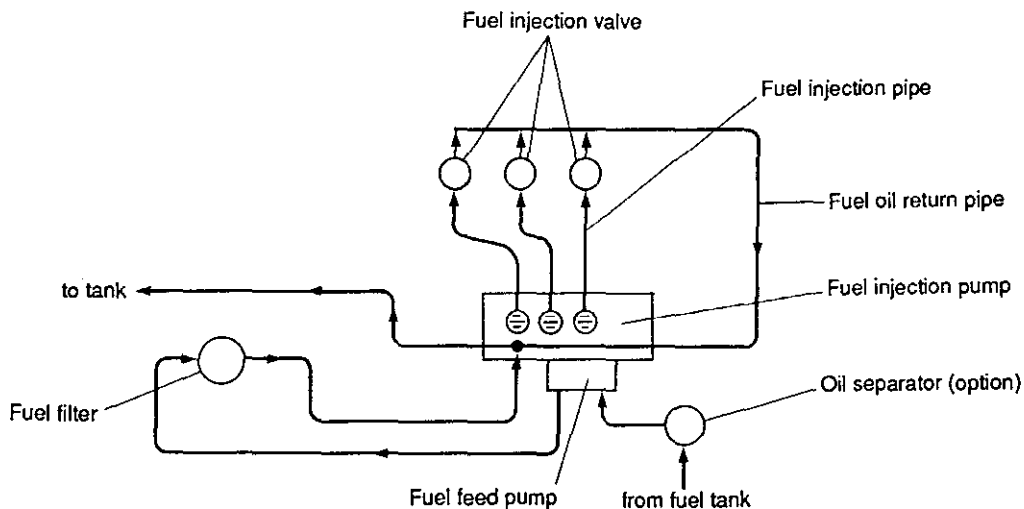

##### (2) Direct injection system

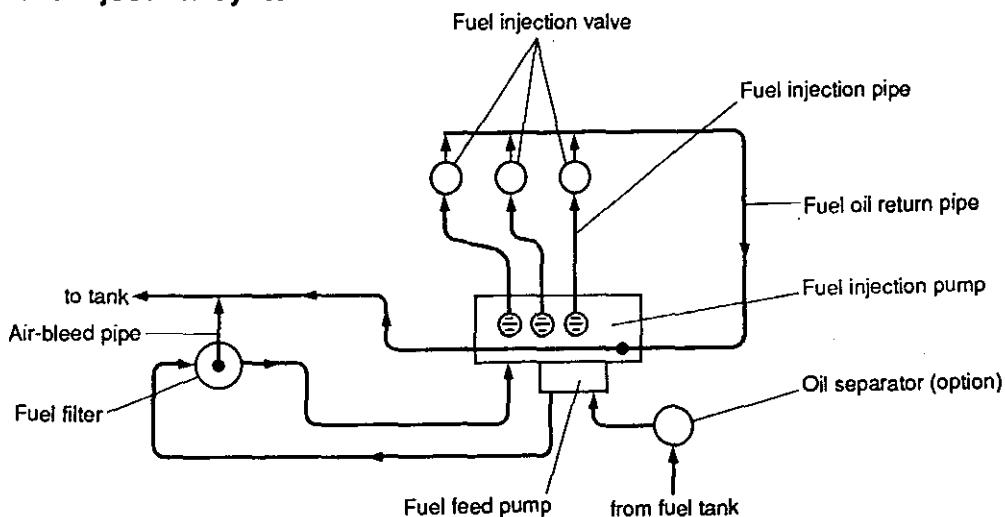



# 4. Troubleshooting

## 4-1. Trouble causes and remedies

The following table summarizes the symptoms and causes of general troubles. If any symptom of trouble is found, a corrective action shall be taken before the said symptom develops into a serious accident.

Carefully read Chapter 6, Measurement, Inspection and Adjustments, and Chapter 7, Measuring Procedures, Service Data and Countermeasures. Familiarize yourself with Chapter 6 and Chapter 7, which practice is extremely important for extending the service life of the engine.

Cause	Symptom of trouble																				Corrective action						
	Fails to start			Insufficient engine output			Poor exhaust color		High knocking sound during combustion	Abnormal engine noise	Hunting			Poor return to low speed	Lubricating oil			Cooling water		Air intake							
	Engine starts but stops soon			Exhaust color			During work				Uneven combustion sound	During idling	During work		Large engine vibration	Excessive fuel consumption	Excessive consumption	Diluted by fuel oil	Mixture with water	Low L.O. pressure		Much blow-by gas	Overheat	Low water temperature	Pressure drop	Pressure rise	Exhaust temperature rise
	Exhaust smoke			Regular	White	Black	White	Black																			
Engine will not start.	Nil	Less	More																								
Engine System	Improper clearance of intake/exhaust valve	<input type="checkbox"/>	<input type="checkbox"/>		<input type="checkbox"/>				<input type="checkbox"/>																Adjust valve clearance (Refer to Chapter 6, 6-2.)		
	Compression leakage from the valve seat				<input type="checkbox"/>		<input type="checkbox"/>	<input type="checkbox"/>	<input type="checkbox"/>					<input type="checkbox"/>						<input type="checkbox"/>	<input type="checkbox"/>					Rap valve seat (Refer to Chapter 7, 7-1-2.)	
	Seized intake/exhaust valve	<input type="checkbox"/>			<input type="checkbox"/>		<input type="checkbox"/>	<input type="checkbox"/>	<input type="checkbox"/>			<input type="checkbox"/>	<input type="checkbox"/>			<input type="checkbox"/>				<input type="checkbox"/>	<input type="checkbox"/>					Correct or replace.	
	Blowout of cylinder head gasket				<input type="checkbox"/>											<input type="checkbox"/>				<input type="checkbox"/>						Replace the gasket. (Refer to Chapter 8, 8-2-(10) )	
	Seized or broken piston ring	<input type="checkbox"/>			<input type="checkbox"/>		<input type="checkbox"/>	<input type="checkbox"/>	<input type="checkbox"/>		<input type="checkbox"/>	<input type="checkbox"/>			<input type="checkbox"/>	<input type="checkbox"/>				<input type="checkbox"/>	<input type="checkbox"/>			<input type="checkbox"/>		Replace the piston ring. (Refer to Chapter 7, 7-4-3, 4, (5) )	
	Worn piston ring, piston and cylinder	<input type="checkbox"/>			<input type="checkbox"/>		<input type="checkbox"/>	<input type="checkbox"/>	<input type="checkbox"/>						<input type="checkbox"/>	<input type="checkbox"/>				<input type="checkbox"/>	<input type="checkbox"/>					Make honing and use oversize parts. (Refer to Chapter 7, 7-2-3. & 7-4-(8) )	
	Seized crank pin metal and bearing	<input type="checkbox"/>	<input type="checkbox"/>						<input type="checkbox"/>		<input type="checkbox"/>	<input type="checkbox"/>	<input type="checkbox"/>							<input type="checkbox"/>	<input type="checkbox"/>					Repair or replace.	
	Improper arrangement of piston ring joints		<input type="checkbox"/>			<input type="checkbox"/>									<input type="checkbox"/>					<input type="checkbox"/>	<input type="checkbox"/>					Correct the ring joint positions. (Refer to Chapter 7, 7-4-(5) )	
	Reverse assembly of the piston ring					<input type="checkbox"/>		<input type="checkbox"/>							<input type="checkbox"/>					<input type="checkbox"/>	<input type="checkbox"/>					Properly reassemble. (Refer to Chapter 7, 7-4-(5) )	
	Worn crank pin and journal metal				<input type="checkbox"/>				<input type="checkbox"/>		<input type="checkbox"/>	<input type="checkbox"/>								<input type="checkbox"/>	<input type="checkbox"/>					Measure and replace. Refer to Chapter 7, 7-5-3. and 7-7-(5) )	
	Loosened connecting rod bolt								<input type="checkbox"/>			<input type="checkbox"/>								<input type="checkbox"/>	<input type="checkbox"/>					Tighten bolt to the specified torque. (Refer to Chapter 10, 10-1.)	
	Foreign matter trapped in combustion chamber	<input type="checkbox"/>							<input type="checkbox"/>						<input type="checkbox"/>					<input type="checkbox"/>	<input type="checkbox"/>					Disassemble and repair the combustion chamber. Eliminate foreign matter.	
	Excessive gear backlash								<input type="checkbox"/>																	Adjust meshing of gears. (Refer to Chapter 7, 7-8-(2) )	
	Worn valve guide of intake/exhaust valves					<input type="checkbox"/>									<input type="checkbox"/>					<input type="checkbox"/>	<input type="checkbox"/>					Measure and replace. (Refer to Chapter 7, 7-1-(3) )	
	Poor governor		<input type="checkbox"/>								<input type="checkbox"/>	<input type="checkbox"/>	<input type="checkbox"/>	<input type="checkbox"/>												Repair and adjust. (Refer to Chapter 13.)	
Improper open/close timing of intake/exhaust valves	<input type="checkbox"/>				<input type="checkbox"/>	<input type="checkbox"/>	<input type="checkbox"/>	<input type="checkbox"/>	<input type="checkbox"/>																Adjust valve clearance (refer to Chapter 6, 6-2) and check intake/exhaust valve timing (Refer to Chapter 9, 9-1)		
Turbocharger	Dirty blower						<input type="checkbox"/>	<input type="checkbox"/>												<input type="checkbox"/>					Clean the blower.		
	Waste gate malfunction						<input type="checkbox"/>	<input type="checkbox"/>													<input type="checkbox"/>				Disassemble and inspect the waste gate.		
	Worn journal bearing					<input type="checkbox"/>	<input type="checkbox"/>																		Disassemble and inspect the journal bearing.		
Cooling Water System	Cooling effect of radiator, excessive						<input type="checkbox"/>							<input type="checkbox"/>					<input type="checkbox"/>						Malfunction of thermostat (kept closed). (Refer to Chapter 6, 6-9)		
	Cooling effect of radiator, insufficient					<input type="checkbox"/>													<input type="checkbox"/>			<input type="checkbox"/>			Malfunction of thermostat (kept opened). (Refer to Chapter 6, 6-9) Slipping fan belt (Refer to Chapter 6, 6-3)		
	Insufficient cooling water level					<input type="checkbox"/>													<input type="checkbox"/>			<input type="checkbox"/>			Check water leakage from Cooling water system (Refer to Chapter 6, 6-7) and clean cooling water system (Refer to chapter 3, 3-1)		
	Cracked water jacket														<input type="checkbox"/>	<input type="checkbox"/>			<input type="checkbox"/>	<input type="checkbox"/>					Repair and replace.		
	Slackened fan belt tension						<input type="checkbox"/>												<input type="checkbox"/>				<input type="checkbox"/>		Adjust fan belt tension. (Refer to Chapter 6, 6-3)		
	Poor thermostat						<input type="checkbox"/>												<input type="checkbox"/>	<input type="checkbox"/>					Check or replace. (Refer to Chapter 6, 6-9)		



## 4-2. Trouble diagnosis through measurement of compression pressure

\* : For the compression pressure measuring procedure, refer to chapter 6, 6-1. Measurement of compression pressure.

Reduction in compression pressure of the cylinder is one of major causes of an increase in blow-by gas (which causes contamination and increased consumption of lubricating oil, and other trouble) as well as the engine starting failure.

The compression pressure is influenced by the following factors:

1. Degree of clearance between the piston and cylinder.
2. Degree of clearance around intake/exhaust valve seats.

3. Gas leak through the nozzle gasket or cylinder head gasket.

In addition, the compression pressure decreases as the engine parts are worn and lose durability through use of the engine for a long period.

Scratches on the cylinder or piston caused by dust or foreign matter through the soiled air cleaner element, and wear or breakage of piston rings also decrease the compression pressure. For this reason, diagnose the engine status by measuring the compression pressure.

### (1) Causes and countermeasures to be taken when the compression pressure is less than the limit value.

\* For the compression pressure limit values, refer to Chapter 6, 6-1 Measurement of compression pressure.

No.	Item	Cause	Countermeasures
1	· Filter element of air cleaner	· Clogged filter element · Broken filter element · Defective filter element seal	· Clean the filter element. · Replace the filter element with a new one.
2	· Valve clearance	· Excessive valve clearance or no clearance	· Adjust the valve clearance (Refer to Chapter 6, 6-2.)
3	· Valve timing	· Improper valve timing · Improper valve clearance	· Adjust the valve clearance (Refer to Chapter 6, 6-2.) · Inspect and adjust of the valve rocker arm. (Refer to Chapter 7, 7-3, 7-6 and 7-8.)
4	· Cylinder head gasket · Nozzle gasket	· Gas leak through the gasket	· Replace the gasket. · Re-tighten the cylinder head and nozzle to the specified torque. (Refer to Chapter 10, 10-1.)
5	· Intake/exhaust valve · Valve seat	· Gas leak caused by worn valve seats or trapped foreign matter · Seizure of valves	· Rap valve seats. (Refer to Chapter 7, 7-1. 2.) · Replace the intake/exhaust valves.
6	· Piston · Piston ring · Cylinder	· Gas leak caused by scratches and wear of piston, piston ring and cylinder	· Perform honing and use oversize parts. (Refer to Chapter 7, 7-2. 3. and 7-4. 8.)



# 5. Special Service Tools and Measuring Instruments

Although main engine parts can be disassembled and reassembled only with standard service tools, it is recommended to provide the following special service tools and measuring instruments for more efficient and accurate work, correct measurement, diagnosis, and troubleshooting.

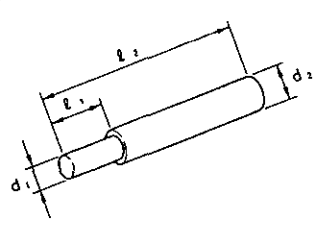
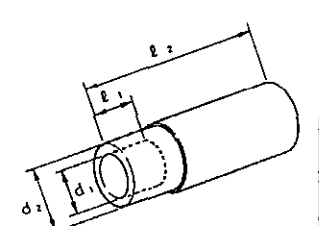
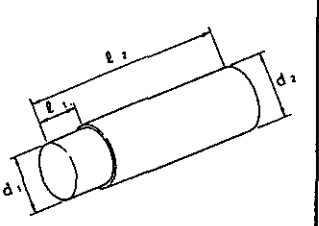
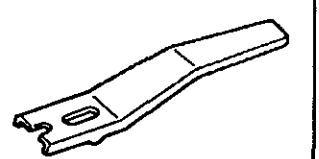

## 5-1. Special service tools

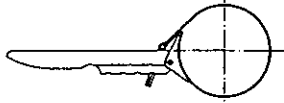
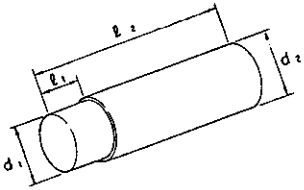
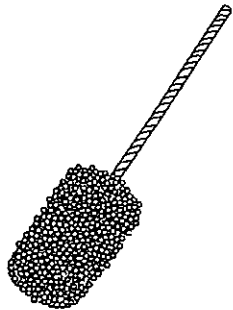
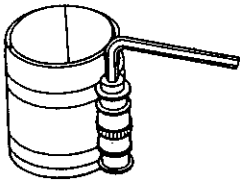
No.	Tool name	Applicable model and tool dimension	Illustration																									
1	Valve guide extraction tool	<p style="text-align: right;">(mm)</p> <table border="1"> <thead> <tr> <th>Dimension Model</th> <th><math>\ell_1</math></th> <th><math>\ell_2</math></th> <th><math>d_1</math></th> <th><math>d_2</math></th> </tr> </thead> <tbody> <tr> <td>2/3TNE68</td> <td>20</td> <td>55</td> <td>5</td> <td>8</td> </tr> <tr> <td>3TNE74</td> <td>20</td> <td>75</td> <td>6.5</td> <td>10</td> </tr> <tr> <td>3TNE78A/82A</td> <td>20</td> <td>75</td> <td>6.5</td> <td>10</td> </tr> <tr> <td>3/4TNE82 3/4TNE84(T) 3/4TNE88</td> <td>20</td> <td>75</td> <td>7.5</td> <td>11</td> </tr> </tbody> </table> <p>* Locally manufactured</p>	Dimension Model	$\ell_1$	$\ell_2$	$d_1$	$d_2$	2/3TNE68	20	55	5	8	3TNE74	20	75	6.5	10	3TNE78A/82A	20	75	6.5	10	3/4TNE82 3/4TNE84(T) 3/4TNE88	20	75	7.5	11	
Dimension Model	$\ell_1$	$\ell_2$	$d_1$	$d_2$																								
2/3TNE68	20	55	5	8																								
3TNE74	20	75	6.5	10																								
3TNE78A/82A	20	75	6.5	10																								
3/4TNE82 3/4TNE84(T) 3/4TNE88	20	75	7.5	11																								
2	Valve guide insertion tool	<p style="text-align: right;">(mm)</p> <table border="1"> <thead> <tr> <th>Dimension Model</th> <th><math>\ell_1</math></th> <th><math>\ell_2</math></th> <th><math>d_1</math></th> <th><math>d_2</math></th> </tr> </thead> <tbody> <tr> <td>2/3TNE68</td> <td>7</td> <td>60</td> <td>11</td> <td>17</td> </tr> <tr> <td>3TNE74</td> <td>9</td> <td>60</td> <td>13</td> <td>19</td> </tr> <tr> <td>3TNE78A/82A</td> <td>12</td> <td>60</td> <td>13</td> <td>19</td> </tr> <tr> <td>3/4TNE82 3/4TNE84(T) 3/4TNE88</td> <td>15</td> <td>65</td> <td>14</td> <td>20</td> </tr> </tbody> </table> <p>* Locally manufactured</p>	Dimension Model	$\ell_1$	$\ell_2$	$d_1$	$d_2$	2/3TNE68	7	60	11	17	3TNE74	9	60	13	19	3TNE78A/82A	12	60	13	19	3/4TNE82 3/4TNE84(T) 3/4TNE88	15	65	14	20	
Dimension Model	$\ell_1$	$\ell_2$	$d_1$	$d_2$																								
2/3TNE68	7	60	11	17																								
3TNE74	9	60	13	19																								
3TNE78A/82A	12	60	13	19																								
3/4TNE82 3/4TNE84(T) 3/4TNE88	15	65	14	20																								
3	Connecting rod bushing replacer	<p style="text-align: right;">(mm)</p> <table border="1"> <thead> <tr> <th>Dimension Model</th> <th><math>\ell_1</math></th> <th><math>\ell_2</math></th> <th><math>d_1</math></th> <th><math>d_2</math></th> </tr> </thead> <tbody> <tr> <td>2/3TNE68</td> <td>22</td> <td>62</td> <td><math>20_{-0.6}^{-0.3}</math></td> <td><math>22_{-0.6}^{-0.3}</math></td> </tr> <tr> <td>3TNE74</td> <td>20</td> <td>80</td> <td><math>21_{-0.6}^{-0.3}</math></td> <td><math>23_{-0.6}^{-0.3}</math></td> </tr> <tr> <td>3TNE78A/82A</td> <td>25</td> <td>85</td> <td><math>23_{-0.6}^{-0.3}</math></td> <td><math>26_{-0.6}^{-0.3}</math></td> </tr> <tr> <td>3/4TNE82 3/4TNE84(T) 3/4TNE88</td> <td>20</td> <td>100</td> <td><math>26_{-0.6}^{-0.3}</math></td> <td><math>29_{-0.6}^{-0.3}</math></td> </tr> </tbody> </table> <p>* Locally manufactured</p>	Dimension Model	$\ell_1$	$\ell_2$	$d_1$	$d_2$	2/3TNE68	22	62	$20_{-0.6}^{-0.3}$	$22_{-0.6}^{-0.3}$	3TNE74	20	80	$21_{-0.6}^{-0.3}$	$23_{-0.6}^{-0.3}$	3TNE78A/82A	25	85	$23_{-0.6}^{-0.3}$	$26_{-0.6}^{-0.3}$	3/4TNE82 3/4TNE84(T) 3/4TNE88	20	100	$26_{-0.6}^{-0.3}$	$29_{-0.6}^{-0.3}$	
Dimension Model	$\ell_1$	$\ell_2$	$d_1$	$d_2$																								
2/3TNE68	22	62	$20_{-0.6}^{-0.3}$	$22_{-0.6}^{-0.3}$																								
3TNE74	20	80	$21_{-0.6}^{-0.3}$	$23_{-0.6}^{-0.3}$																								
3TNE78A/82A	25	85	$23_{-0.6}^{-0.3}$	$26_{-0.6}^{-0.3}$																								
3/4TNE82 3/4TNE84(T) 3/4TNE88	20	100	$26_{-0.6}^{-0.3}$	$29_{-0.6}^{-0.3}$																								
4	Valve spring compressor (Replacement of valve spring)	<table border="1"> <thead> <tr> <th>Model</th> <th>Yanmar Code No.</th> </tr> </thead> <tbody> <tr> <td>All model</td> <td>129100-92630</td> </tr> </tbody> </table>	Model	Yanmar Code No.	All model	129100-92630																						
Model	Yanmar Code No.																											
All model	129100-92630																											

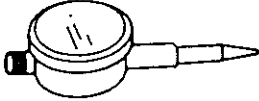
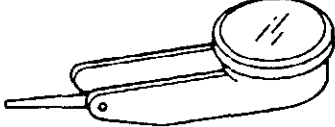
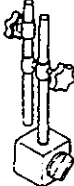
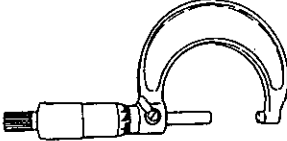
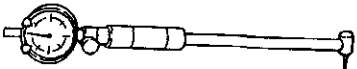

## 5. Special Service Tools and Measuring Instruments

No.	Tool name	Applicable model and tool dimension	Illustration																									
5	Filter wrench (Removal and installation of L.O. filter)	Sold on market																										
6	Camshaft bushing tool (Extraction of camshaft bushing)	<p style="text-align: right;">(mm)</p> <table border="1"> <thead> <tr> <th>Dimension Model</th> <th><math>\ell_1</math></th> <th><math>\ell_2</math></th> <th><math>d_1</math></th> <th><math>d_2</math></th> </tr> </thead> <tbody> <tr> <td>2/3TNE68</td> <td>13</td> <td>60</td> <td><math>36_{-0.6}^{-0.3}</math></td> <td><math>39_{-0.6}^{-0.3}</math></td> </tr> <tr> <td>3TNE74</td> <td>14</td> <td>60</td> <td><math>40_{-0.6}^{-0.3}</math></td> <td><math>43_{-0.6}^{-0.3}</math></td> </tr> <tr> <td>3TNE78A/82A</td> <td>18</td> <td>70</td> <td><math>45_{-0.6}^{-0.3}</math></td> <td><math>48_{-0.6}^{-0.3}</math></td> </tr> <tr> <td>3/4TNE82 3/4TNE84(T) 3/4TNE88</td> <td>18</td> <td>70</td> <td><math>45_{-0.6}^{-0.3}</math></td> <td><math>48_{-0.6}^{-0.3}</math></td> </tr> </tbody> </table> <p>* Locally manufactured</p>	Dimension Model	$\ell_1$	$\ell_2$	$d_1$	$d_2$	2/3TNE68	13	60	$36_{-0.6}^{-0.3}$	$39_{-0.6}^{-0.3}$	3TNE74	14	60	$40_{-0.6}^{-0.3}$	$43_{-0.6}^{-0.3}$	3TNE78A/82A	18	70	$45_{-0.6}^{-0.3}$	$48_{-0.6}^{-0.3}$	3/4TNE82 3/4TNE84(T) 3/4TNE88	18	70	$45_{-0.6}^{-0.3}$	$48_{-0.6}^{-0.3}$	
Dimension Model	$\ell_1$	$\ell_2$	$d_1$	$d_2$																								
2/3TNE68	13	60	$36_{-0.6}^{-0.3}$	$39_{-0.6}^{-0.3}$																								
3TNE74	14	60	$40_{-0.6}^{-0.3}$	$43_{-0.6}^{-0.3}$																								
3TNE78A/82A	18	70	$45_{-0.6}^{-0.3}$	$48_{-0.6}^{-0.3}$																								
3/4TNE82 3/4TNE84(T) 3/4TNE88	18	70	$45_{-0.6}^{-0.3}$	$48_{-0.6}^{-0.3}$																								
7	Flex-Hone (for honing cylinder liner) * : For the usage procedure of the Flex-Hone, refer to Chapter 7, 7-2, 3.	<table border="1"> <thead> <tr> <th>Model</th> <th>Yanmar Code No.</th> </tr> </thead> <tbody> <tr> <td>2/3TNE68</td> <td>129400-92400</td> </tr> <tr> <td>3TNE74</td> <td>129400-92410</td> </tr> <tr> <td>3TNE78A/82A 3/4TNE82 3/4TNE84(T)</td> <td>129400-92420</td> </tr> <tr> <td>3/4TNE88</td> <td>129400-92430</td> </tr> </tbody> </table>	Model	Yanmar Code No.	2/3TNE68	129400-92400	3TNE74	129400-92410	3TNE78A/82A 3/4TNE82 3/4TNE84(T)	129400-92420	3/4TNE88	129400-92430																
Model	Yanmar Code No.																											
2/3TNE68	129400-92400																											
3TNE74	129400-92410																											
3TNE78A/82A 3/4TNE82 3/4TNE84(T)	129400-92420																											
3/4TNE88	129400-92430																											
8	Piston insertion tool (Insertion of piston)	<table border="1"> <thead> <tr> <th>Model</th> <th>Yanmar Code No.</th> </tr> </thead> <tbody> <tr> <td>All model</td> <td>95550-002476</td> </tr> </tbody> </table> <p>Note: The above piston insertion tool is applicable to pistons 60~125 mm in diameter.</p>	Model	Yanmar Code No.	All model	95550-002476																						
Model	Yanmar Code No.																											
All model	95550-002476																											
9	Piston ring replacer	Sold on market																										

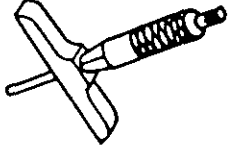
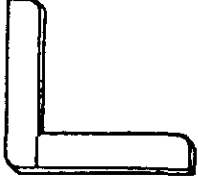
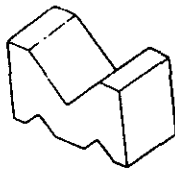
## 5-2. Measuring instruments

No.	Instrument name	Purpose of use	Illustration
1	Dial gauge	Measures bent shafts, distorted flat surface, gaps, etc.	
2	Test indicator	Measures the limited small portions and deep portions unmeasurable with dial gauge.	
3	Magnetic stand	Used together with the dial gauge: holds the dial gauge at different angles.	
4	Micrometer	Measures the outside diameter of the crankshaft, piston, and piston pin, etc.	
5	Cylinder gauge	Measures the inside diameter of the cylinder liner, connecting rod metal, etc.	
6	Vernier callipers	Measures the outside diameter, depth, thickness, width, etc. of various items.	
7	Depth Micrometer	Measures the sinkage of the valve.	
8	Square	Measures inclination of valve spring, squareness of engine parts, etc.	
9	V-block	Measures bent shaft.	

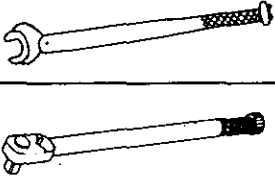
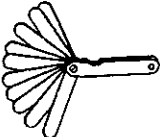
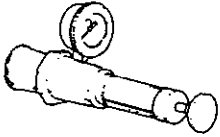
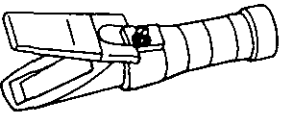
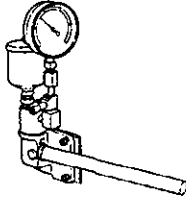
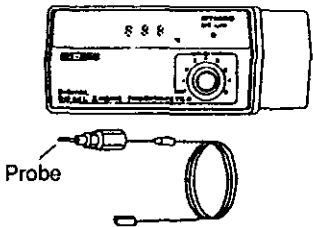
**5. Special Service Tools and Measuring Instruments**

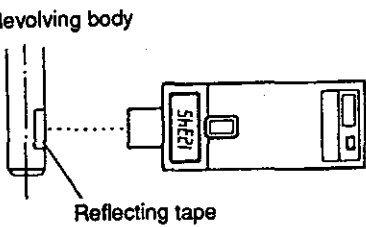
No.	Instrument name	Purpose of use	Illustration
10	Torque wrench	Used for tightening bolts and nuts to the specified torques.	
11	Thickness gauge	Measures gaps between the rings and mating ring grooves and around shaft couplings during installation	
12	Cap tester	Checks the fresh water system for leakage.	
13	Battery coolant tester	Checks the antifreeze for concentration and the battery electrolyte for specific gravity, and charging state.	
14	Nozzle tester	Checks the fuel injection valve for spray patterns and injection pressure.	
15	Digital thermometer	Measures temperature of each part.	
16	Contact type	Measures RPM of the rotary shaft by bringing the gage head into contact with the mortise.	
	Photoelectric type	Applies a reflecting tape on the circumference of the rotating parts to measure RPM.	

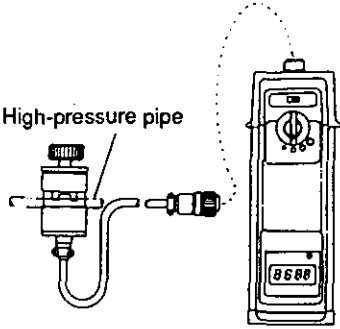
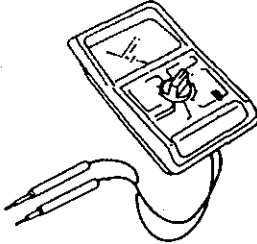
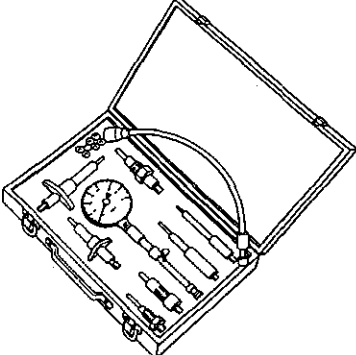
No.	Instrument name	Purpose of use	Illustration
16	Tachometer High pressure fuel pipe clamping type	Measures engine RPM's using pulse system, irrelevantly to the center of the rotary shaft and the circumference of the rotary object.	
17	Circuit tester	Measures the resistance, voltage, and continuity of electric circuits.	
18	Compression gauge kit	Measures compression pressure. <div style="border: 1px solid black; padding: 5px; margin: 10px auto; width: fit-content;">                         Yanmar Code No.                          TOL-97190080                     </div>	



## 6. Measurement, Inspection and Adjustment

### 6-1. Measuring the compression pressure

#### 1. Measuring Procedure

(1) Warm up the engine. Remove the fuel injection pipe and fuel injection valve from the cylinder to be measured.

(2) Crank the engine before attaching the compression gauge adapter.

\* : 1. Crank the engine when the regulator handle has been turned to "STOP" position (no injection state).

2. For the compression gauge and compression gauge adapter, refer to Chapter 5, 5-2.

(3) Attach the compression gauge adapter and compression gauge to the cylinder to be measured.

\* : Never fail to attach the gasket to the tip of the adapter.

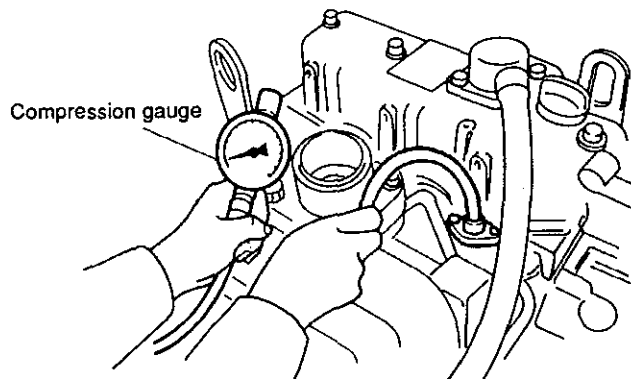

Measuring the compression pressure

(4) Crank the engine by the starting motor until the reading of the compression gauge is stabilized, by taking steps shown in (2), \*1.

#### [Reference: List of Engine Compression Pressures]

Model	Compression pressure at 250 rpm (kgf/cm <sup>2</sup> )		Dispersion of compression pressure among cylinders (kgf/cm <sup>2</sup> )
	Standard	Limit	
2TNE68	33 ± 1	25	2 ~ 3
3TNE68	33 ± 1	25	2 ~ 3
3TNE74	35 ± 1	27	2 ~ 3
3TNE78A	32 ± 1	25	2 ~ 3
3TNE82A	31 ± 1	24	2 ~ 3
3TNE82	31 ± 1	24	2 ~ 3
3TNE84	33 ± 1	25	2 ~ 3
3TNE88	35 ± 1	27	2 ~ 3
4TNE82	31 ± 1	24	2 ~ 3
4TNE84	33 ± 1	25	2 ~ 3
4TNE88	35 ± 1	27	2 ~ 3
3TNE84T	30 ± 1	24	2 ~ 3
4TNE84T	30 ± 1	24	2 ~ 3

Reference: Variation of Compression Pressure with Engine Speed

(1) Indirect injection system

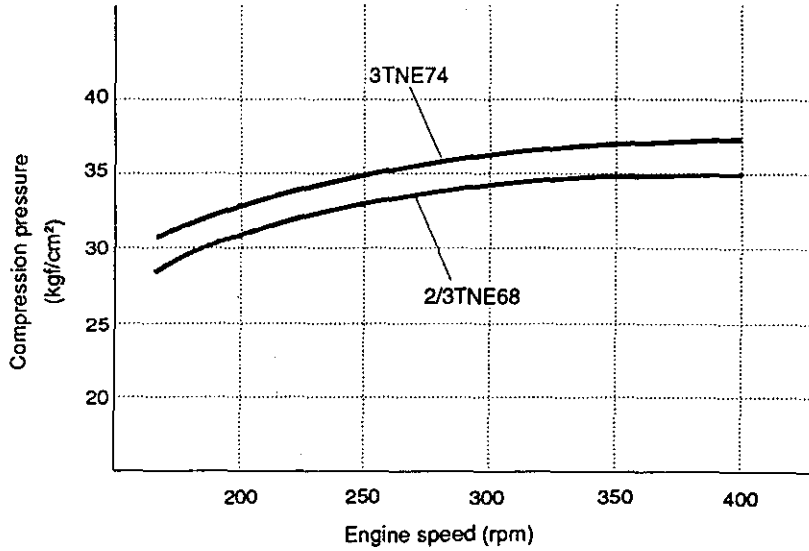

(2) Direct Injection system

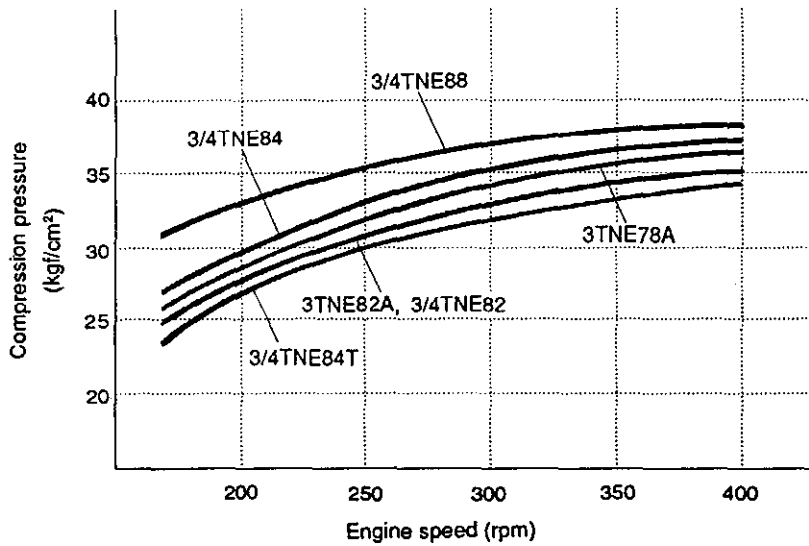

2. Action to be taken when the measured compression pressure is below the limit value.

Trouble occurs in a part of the engine. For troubleshooting, refer to Chapter 4, 4-2 trouble diagnosis through measurement of compression pressure.

## 6-2. Adjusting the valve head clearance

- (1) Inspect and adjust a valve head clearance while the engine is in cold state.
- (2) Raise the piston in the cylinder to be measured to the top dead center (TDC) of compression.
- (3) Loosen the lock nut and adjusting screw. Make sure that the valve cap is free from inclination or trapped dirt.

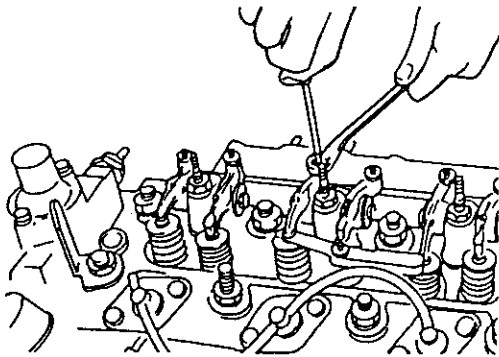
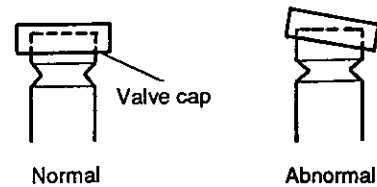

- (4) Insert a thickness gauge in between the rocker arm and valve cap. Tighten the adjusting screw until the clearance listed below is attained.

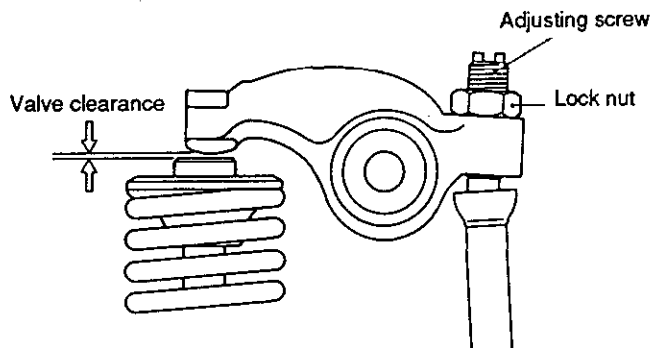

(Adjusting the valve head clearance)

(mm)

	All models
Intake/exhaust valve head clearance	0.15 ~ 0.25

\* : 1. If the valve cap is worn or otherwise damaged on the head, replace it with a new one.

2. Make sure that the valve cap is nested on the head of intake/exhaust valves.

### 6-3. Checking the V-belt tension

Push the center of the V-belt between the alternator and cooling water pump with a finger. If the deflection is 10–15 mm, the V-belt tension is acceptable. If not, adjust the V-belt tension using the adjuster at the alternator.

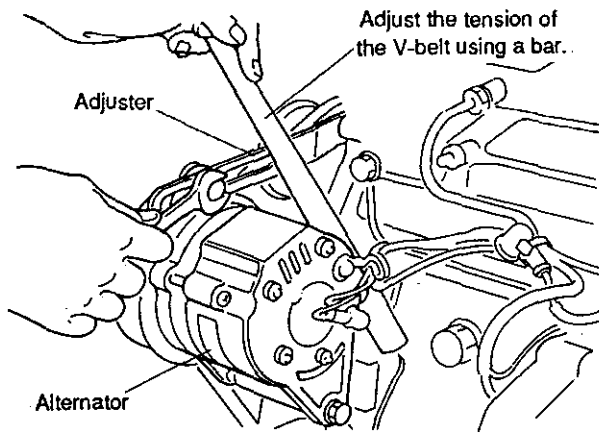

(Adjustment of the V-belt tension)

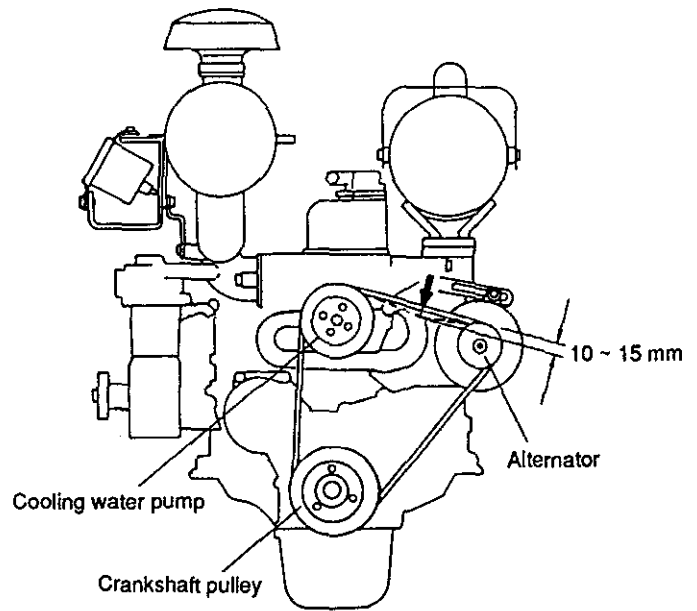

### 6-4. Measuring and checking the injection pressure and spray patterns of the fuel injection valve

#### 1. Measuring the injection pressure

\* : Thoroughly remove carbon deposits from the injection nozzle before making measurement.

- (1) Connect the fuel injection valve to the high pressure pipe of the nozzle tester.
- (2) While pumping the lever of the nozzle tester slowly, read the pressure gauge on the nozzle tester the moment the nozzle starts fuel injection.

\* : For injection pressure of each engine, refer to Chapter 1, "Specifications and Performance".

- (3) If the measured injection pressure is lower than the specified value, replace the pressure adjusting shim with a thicker one.

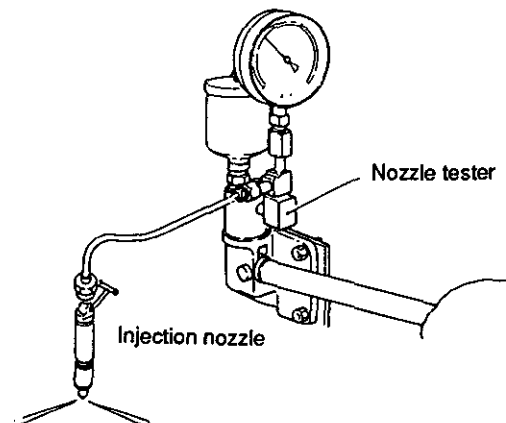

( Measuring the injection pressure with )  
a nozzle tester

	Type of pressure adjusting shim thickness (mm)	Injection pressure adjustment
Indirect injection system	0.1, 0.2, 0.3, 0.4, 0.5	Increase the pressure adjusting shim the thickness by 0.1 mm and the injection pressure is increased by 7-10 kgf/cm <sup>2</sup> .
Direct injection system	0.13, 0.15, 0.18, 0.4, 0.5, 0.8	Increase the pressure adjusting shim thickness by 0.1 mm and the injection pressure is increased by about 19 kgf/cm <sup>2</sup> .

[Reference: Structure of fuel Injection valve]

(Indirect injection system)

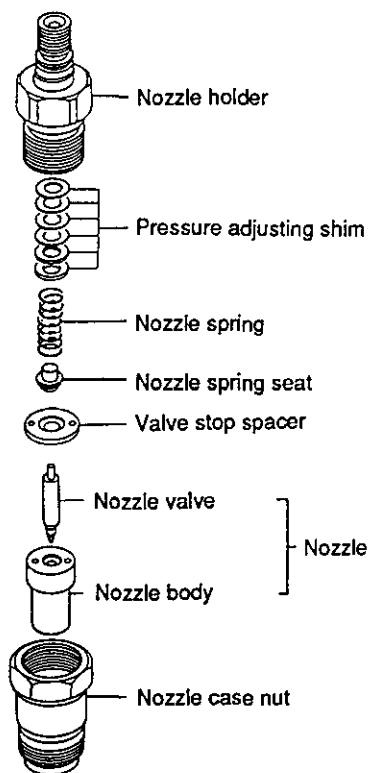

(Direct injection system)

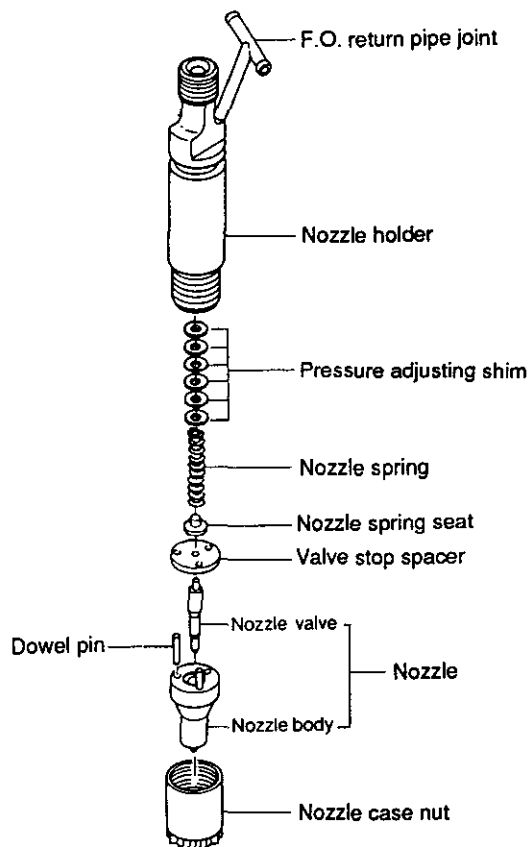

**2. Checking the spray patterns**

While pumping the lever of the nozzle tester 4-6 times per second at the specified injection pressure (Refer to Chapter 1, specifications and performance), check the spray patterns. If the following trouble is found, clean or replace the nozzle.

- (1) Make sure that the pattern is neither stream nor sliver.
- (2) Ensure that fuel is sprayed conically around the nozzle center line and that a fuel injection spreading angle is 5-10° in the indirect injection system or approx. 150° in the direct injection system.

[Normal spray pattern]

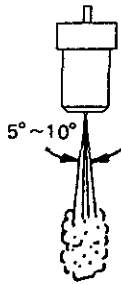

(Indirect injection system)

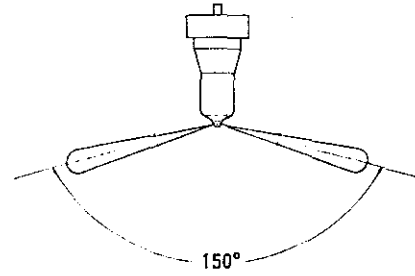

(Direct Injection system)

[Abnormal spray patterns]

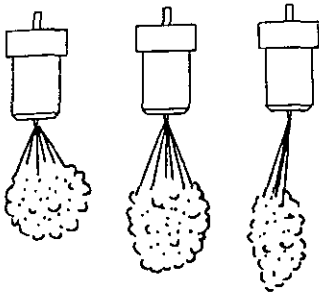

(Indirect injection system)

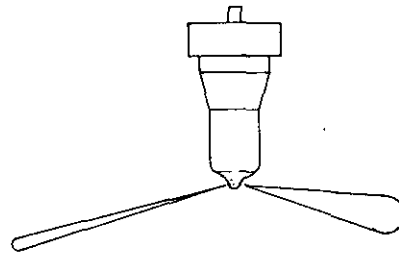

(Direct injection system)

- (3) Place a sheet of white paper 30 cm below the nozzle. The injection spray should form a perfect circle.
- (4) No oil should drip from the nozzle after injection.
- (5) Oil should not ooze from the injection hole when the pressure is raised to a little less than the specified 20 kgf/cm<sup>2</sup>.
- (6) Test the injection with a nozzle tester; re-tighten and test again if there is excessive oil leak from the overflow coupling. Replace the nozzle as a set if the leaking oil is still excessive.

**3. Nozzle valve sliding test**

Thoroughly wash the nozzle valve using clean diesel oil. Hold the nozzle body vertically, and lift the nozzle valve approx. 1/3 of its length with one hand.

Check to see if the nozzle falls smoothly by itself gravity when released. If so, the nozzle valve is good. In case of a new nozzle, remove the seal peel, and immerse it in clean diesel oil or the like to clean the inner and outer surfaces and to thoroughly remove rust-preventive oil before using the nozzle. Note that a new nozzle is coated with rust-preventive oil and is pasted with the seal peel to shut off outer air.

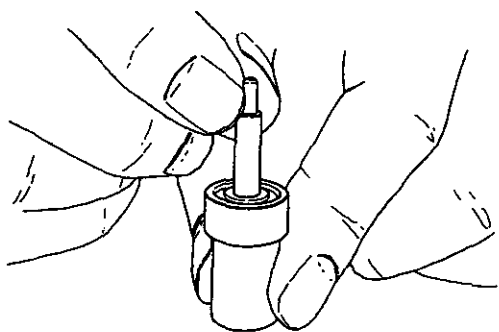

( Nozzle valve sliding check by gravity )  
for indirect injection system

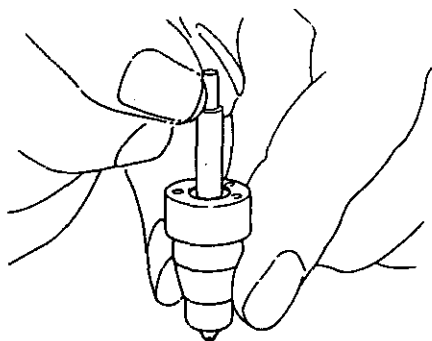

( Nozzle valve sliding check by gravity )  
for direct injection system

**4. Nozzle body identification number**

(Indirect injection system)

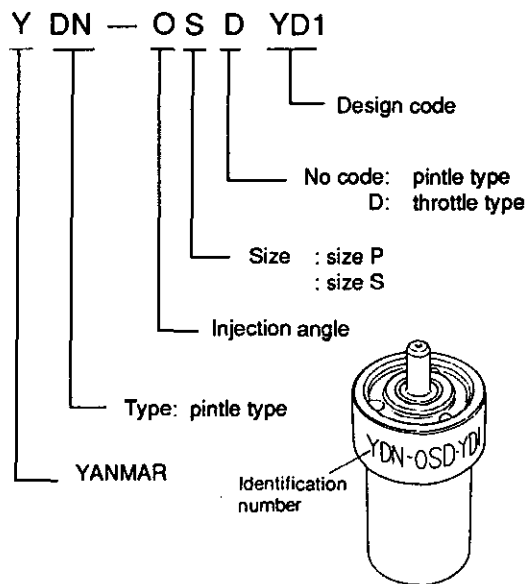

(Direct injection system)

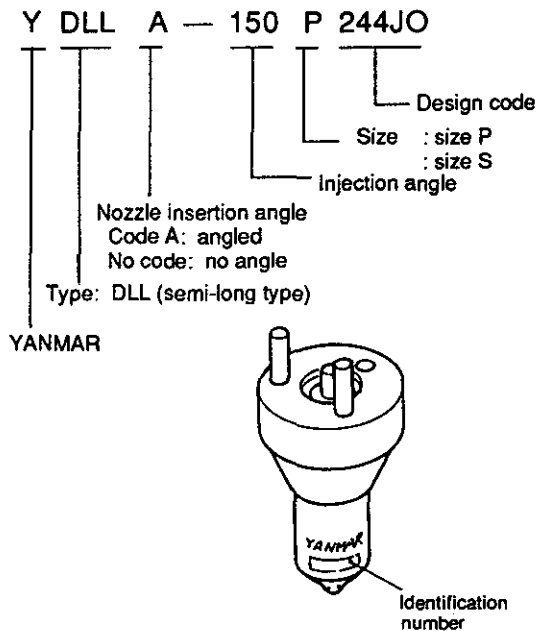

## 6-5. Checking and adjusting the fuel injection timing

### 1. Indirect Injection system

- (1) Using the crankshaft pulley, turn the engine in the specified direction. Check the injection timing at the delivery valve of the fuel injection pump for cylinder No.1. (Cylinders are numbered sequentially from cylinder No. 1 from the flywheel side).

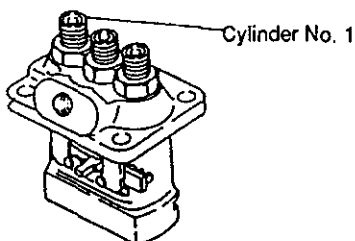
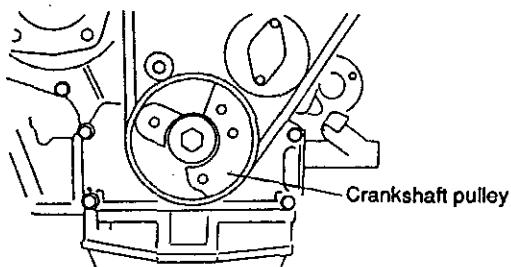

- (2) When the crankshaft is turned in the specified direction, oil level rises at the tip of the delivery valve spring holder. At that time, stop the crankshaft.
- (3) Identify the timing mark stamped on the flywheel through the access hole of the flywheel housing.

\* : For the fuel injection timing of each engine model, refer to Chapter 1, Specifications and Performance.

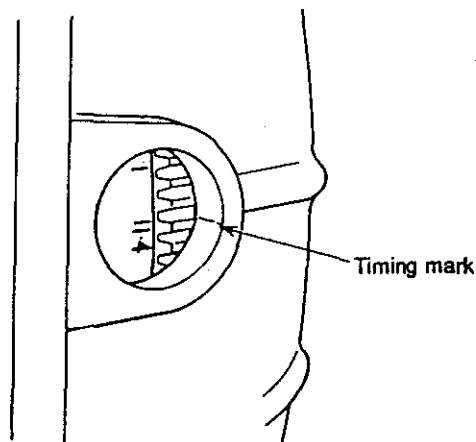
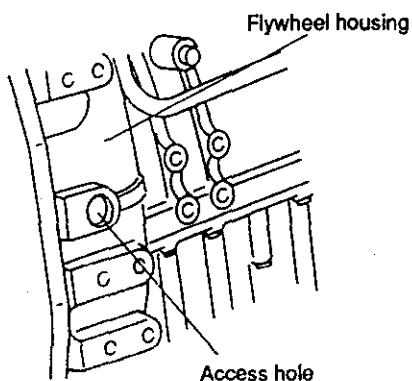

- (4) If the present injection timing differs from the specified timing, remove the fuel injection pump, and adjust the timing by increasing or decreasing the adjusting shim thickness between the fuel injection pump and gear case.
- Increase the shim thickness to delay the injection timing.
  - Decrease the shim thickness to advance the injection timing.

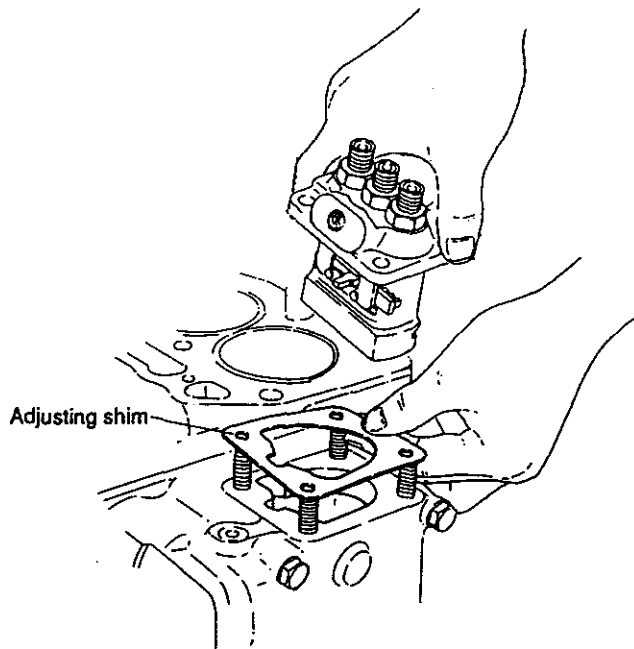



## 2. Direct injection system

- (1) Using the crankshaft pulley, turn the engine in the specified direction. Check the injection timing at the delivery valve of the fuel injection pump for cylinder No.1. (Cylinders are numbered sequentially from cylinder No. 1 from the flywheel side).

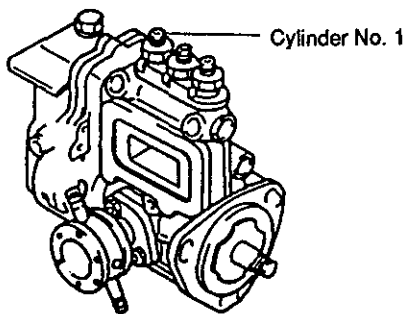
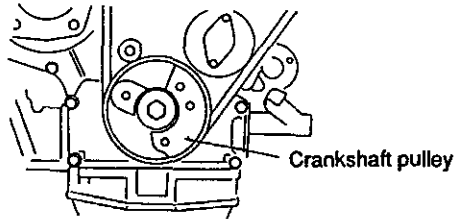

- (2) When the crankshaft is turned in the specified direction, the oil level rises at the tip of the delivery valve spring holder. At that time, stop the crankshaft.
- (3) Identify the timing mark stamped on the flywheel through the access hole of the flywheel housing.

\*: For fuel injection timing for each engine model, refer to Chapter 1, Specifications and Performance.

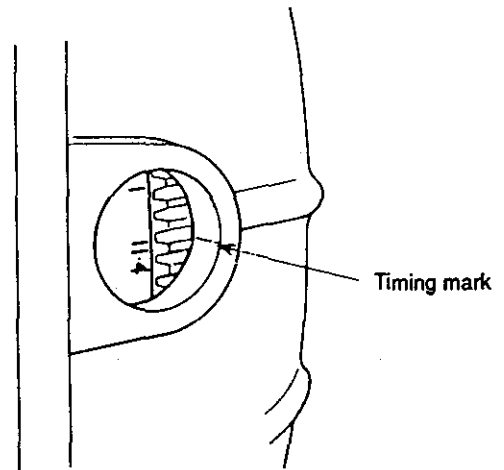
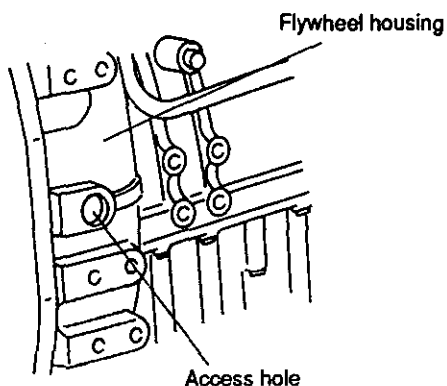

- (4) If the measured injection timing differs from the specified timing, adjust the injection timing by turning down the fuel injection pump toward the engine or to the opposite side after loosening the lock nut of the fuel injection pump.
- If injection timing is late, turn down the fuel injection pump away from the engine.
  - If the injection timing too early, turn the injection pump down toward the engine.

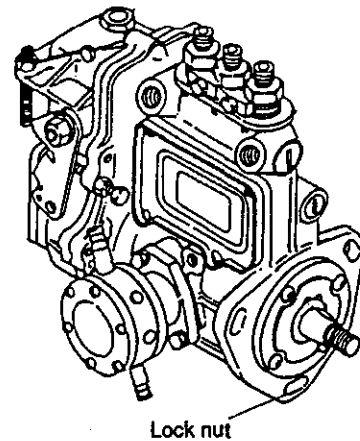

## 6-6. Adjusting the no-load maximum (or minimum) revolutions

- (1) First warm up the engine. Then, gradually increase the engine speed up to the no-load max. revolution (Refer to Chapter 1, Specifications and Performance).
- (2) If the present no-load max. revolution differ from the specified one, adjust the no-load max. revolution using the no-load max. revolution adjusting bolt.
- (3) Set the engine to the idling revolution, (Refer to Chapter 1, Specifications and Performance) by turning the no-load min. revolution adjusting bolt.

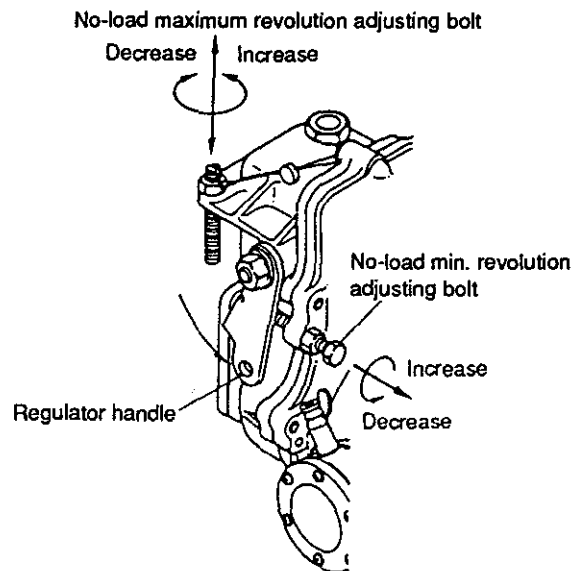

\* : The illustration shows the partial perspective view of the governor for the direct injection system.

## 6-7. Checking the cooling water system and radiator for water leakage

### 1. Checking the cooling water system for water leakage

\* : The cooling water system can be checked effectively while the engine is warm.

- (1) Supply cooling water up to the normal water level in the radiator. Attach the cap tester body to the radiator.
- (2) Start the cooling water pump, and set it to a pressure of  $0.9 \pm 0.15 \text{ kgf/cm}^2$ . Any lower reading of the pressure gauge on the cap tester indicates water leak from the cooling water system. Then, detect the portion where cooling water leaks from the cooling water system.

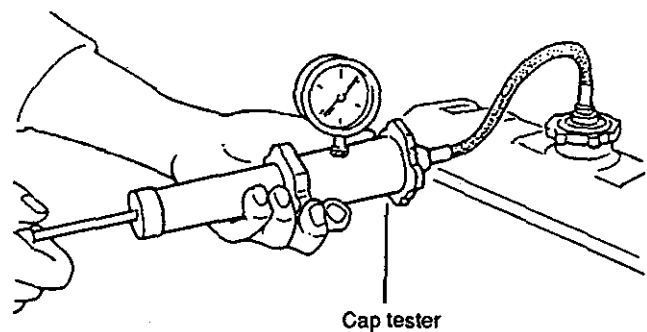

( Checking the cooling water system for water leakage )

### 2. Checking the radiator cap

Attach the radiator cap to a cap tester. Set the tester to a pressure of  $0.9 \pm 0.15 \text{ kgf/cm}^2$ . Check to see if the cap is opened at the set pressure. If not, replace the cap, because it is defective.

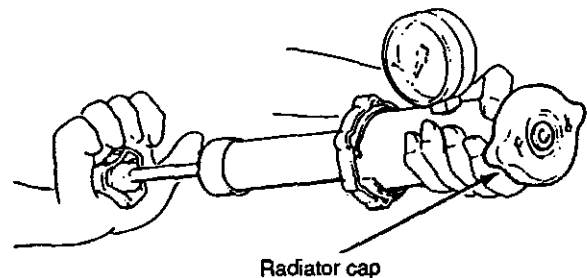

( Checking the radiator cap )

## 6-8. Checking the battery

### 1. Structure of the battery

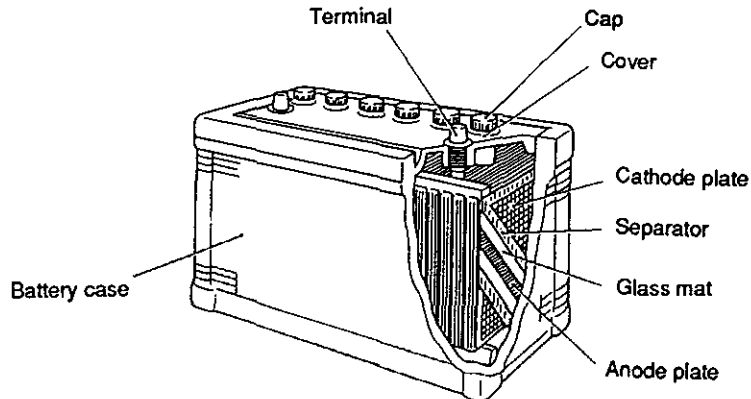

### 2. Checking the battery

#### (1) Electrolyte level

Check the electrolyte level in each cell. If the level is low, add deionized water to bring the level to the UPPER level as illustrated below.

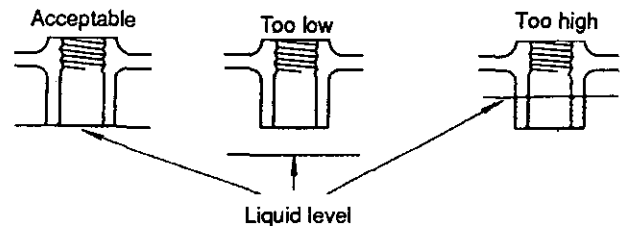
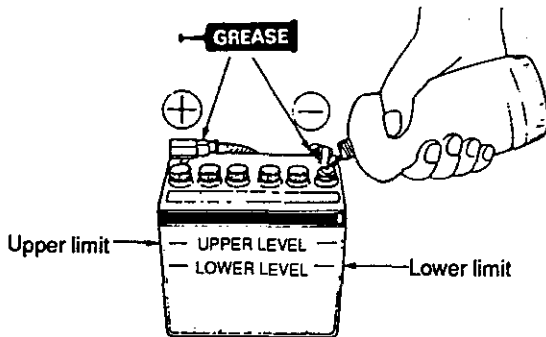

#### (2) Battery charge

Using a battery tester or hydrometer, check the state of the battery. If the battery is discharged, recharge it.

##### ○ Measurement with a battery tester

To check the battery with a battery tester, securely hold the  $\oplus$  terminal of the battery with the red clip of the battery tester and the  $\ominus$  terminal with the black clip. Judge battery charge level from the indicator position:

- Green zone: normal
- Yellow zone: somewhat discharged
- Red zone: abnormal or much discharged

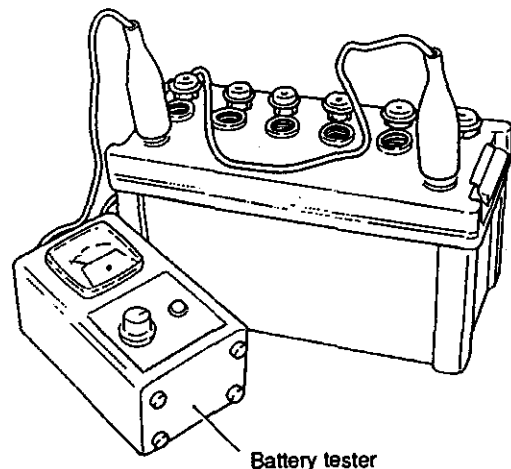

( Measuring the battery charge )  
with battery tester

○ Measurement with a hydrometer

When using a hydrometer, correct the measured specific gravity according to the temperature. The specific gravity of the electrolyte of the battery is the standard when measured at 20°C. Correct the specific gravity according to the following equation, as it changes by 0.0007 per 1°C.

$$S_{20} = S_t + 0.0007 (t - 20)$$

$S_{20}$  — Specific gravity converted to 20°C  
 $S_t$  — Measured specific gravity  
 $t$  — Measured electrolyte temperature

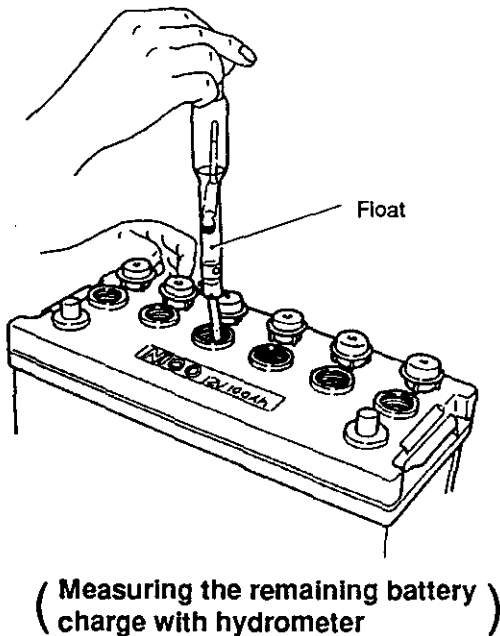

Hydrometer and remaining battery charge

Specific gravity (at 2°C)	Discharged level (%)	Remaining level (%)
1.260	0	100
1.210	25	75
1.160	50	50
1.110	75	25
1.060	100	0

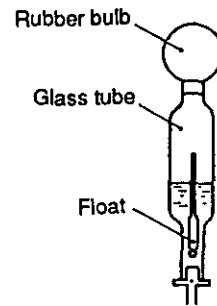

(Hydrometer)

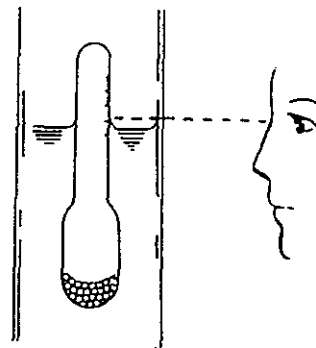

(How to read a hydrometer)

- (3) **Terminals**  
Repair or clean the terminals if corroded or soiled.
- (4) **Fittings**  
Repair or replace the fittings if corroded. Re-tighten them if loosened.
- (5) **Appearance of the battery**  
Replace the battery if cracked or deformed. Clean it using fresh water if contaminated.

## 6-9. Checking the sensors

### 1. Checking the thermostat and thermoswitch

#### (1) Thermostat

Put a thermostat into water in a container. While measuring water temperature, heat the water. Make sure that the thermostat functions at a temperature of 69.5-72.5°C. (80.5 ~ 83.5°C are used as option parts)

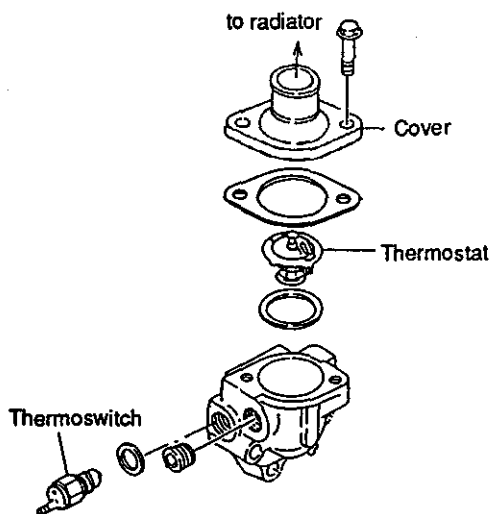
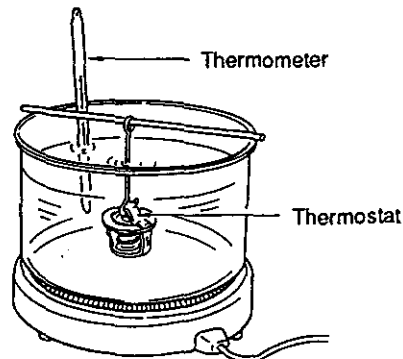

#### (2) Thermoswitch

Put a thermoswitch into an antifreeze or oil in a container. While measuring liquid temperature, heat the liquid. If the tester shows continuity at a temperature of 107-113°C, the thermoswitch is acceptable.

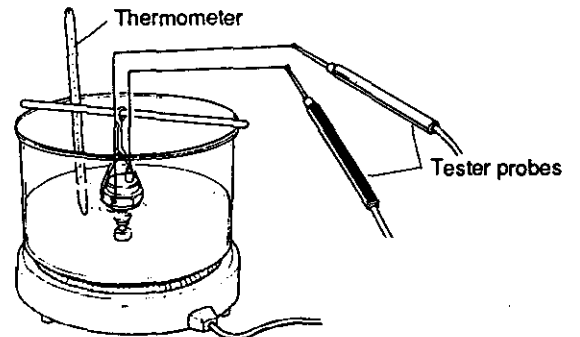

#### 2. LO pressure switch

Remove the connector from the LO pressure switch.

While running the engine, bring the tester probes into contact with the switch terminal and cylinder block. If the tester shows continuity, the LO pressure switch is defective.

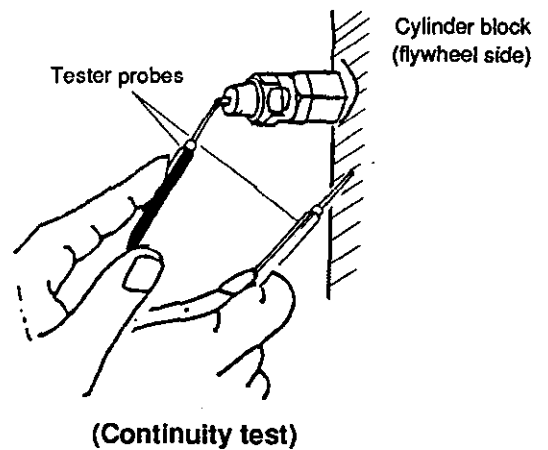

## 6-10. Checking the Oil Cooler

The oil cooler is of the core type and cooled by fresh water. It is installed as a standard component on turbocharged engines in the TNE series.

- (1) Replace the packing at the joint and O-rings at the time of reassembly after disassembly.
- (2) When the oil cooler is disassembled and cleaned for periodic inspection, remove the scale by using descaling agent "Unicon 146".
- (3) Cooling tube leak check  
Close either the inlet or outlet of the cooling tube. Apply an air pressure (5.0 kg/cm<sup>2</sup>) from the other end and check if air is leaking by immersing the tube in water. If leaking, repair or replace the cooling tube.

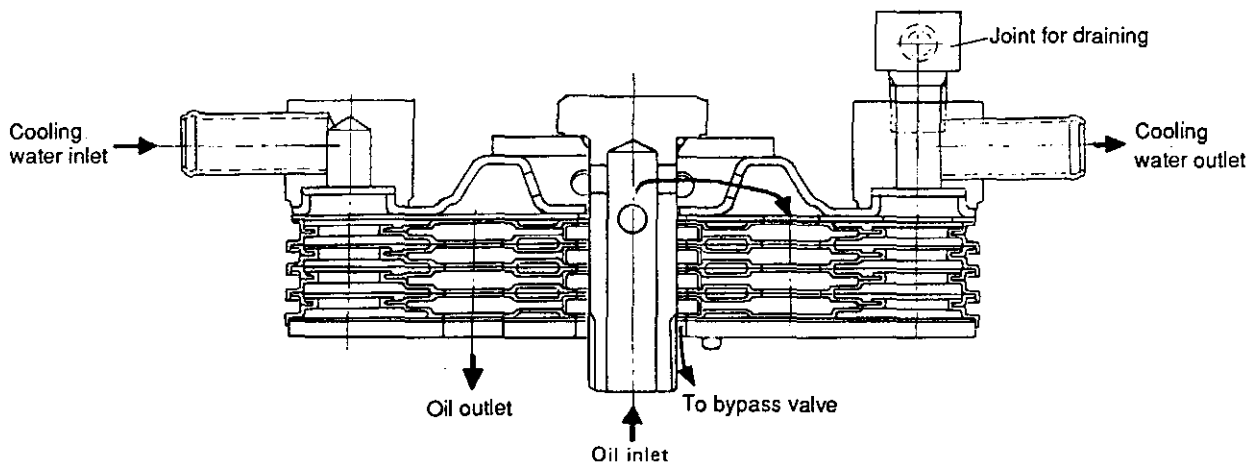

## 6-11. Checking the Piston Cooling Nozzle

The piston cooling nozzle is installed as a standard component on turbocharged engines in the TNE series.

### (1) Piston cooling nozzle function

A nozzle made of a steel pipe is installed below the main gallery in the cylinder body. The lubricating oil from the main gallery is constricted at the nozzle hole ( $\phi 1.77$  mm) at the tip end of the steel pipe to be jet-sprayed. This jet spray comes into contact with the rear face of the piston for cooling it.

Jet flow rate	1.3 e/ min
Jetting pressure	3.5 kg / cm <sup>2</sup>

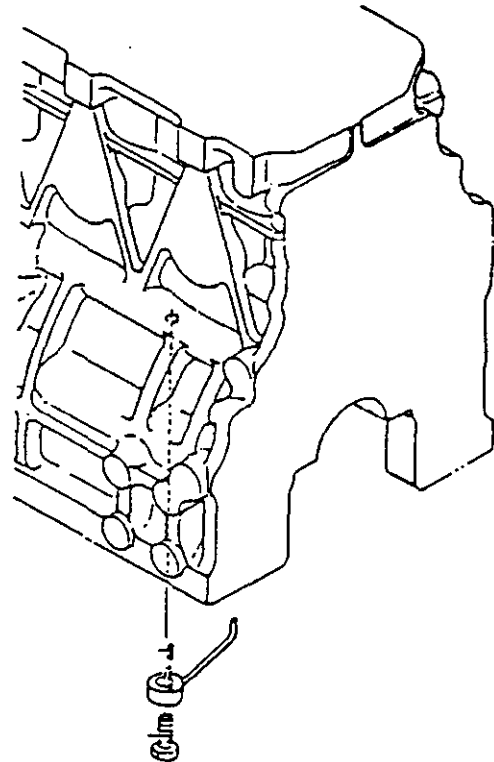
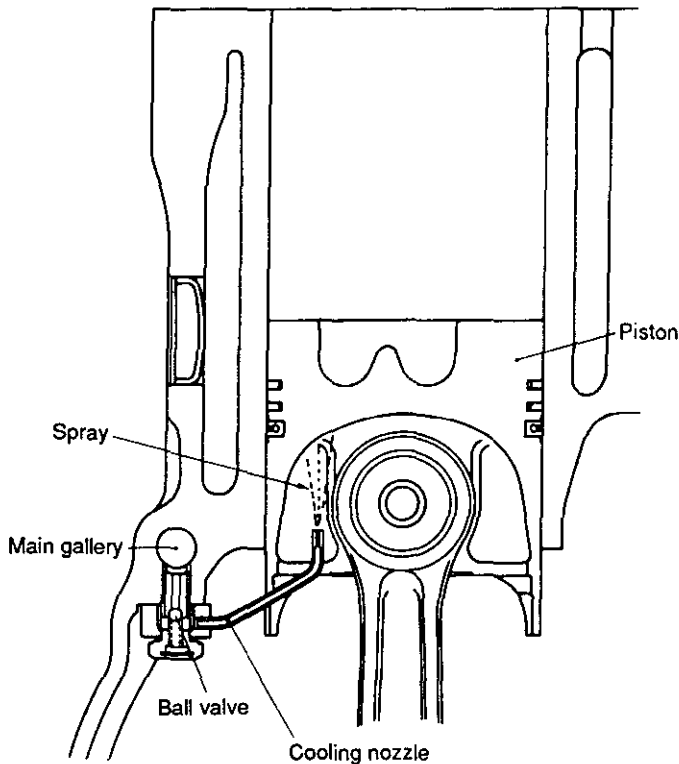

### (2) Checking the piston cooling nozzle

1. Check the nozzle hole at the tip end for clogging with dirt or foreign matter, and clean it.
2. Check the brazed portion of the steel pipe for loosening or freeing by vibration. Replace with a new part if defective.

# 7. Measuring Procedure, Service Data and Corrective Action

In maintaining various parts, make measurement according to the following measurement procedure. If any trouble is found and if any part deviates from the standard size, replace it with a new one. However, if any part within the limit is expected to deviate from the standard presumably because of the record of its use, be sure to replace such a part beforehand.

## 2. Intake/exhaust valve seats

### (1) Valve sinking

Over long periods of use and repeated lappings, combustion efficiency may drop. Measure the sinking depth and replace the valve and valve seat if the valve sinking depth exceeds the standard value.

## 7-1. Cylinder head

### 1. Distortion and inspection of the combustion surface

- (1) Remove intake/exhaust valves and fuel injection valve from the engine. Clean the surface of the cylinder head.
- (2) Place a straight-edge along each of the four sides and each diagonal of the cylinder head. Measure the clearance between the straight-edge and combustion surface with a thickness gauge.

Cylinder head combustion surface distortion	(mm)	
	Standard	Wear limit
All models	0.05 or less	0.15

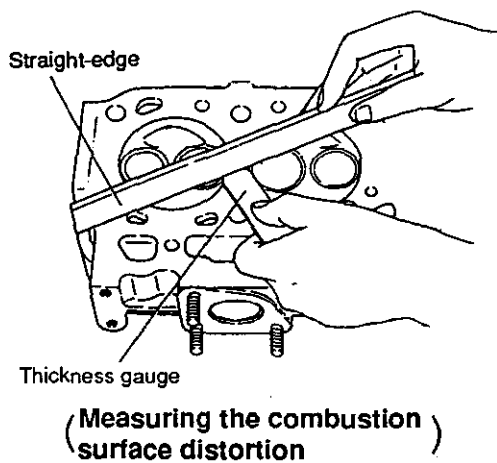

		2/3TNE68		3TNE74	
		Standard	Wear limit	Standard	Wear limit
Valve sinking depth	Intake valve	0.3~0.5	1.0	0.4~0.6	1.0
	Exhaust valve	0.75~0.95	1.0	VM:0.75~0.95 CH:0.40~0.60 VH:0.40~0.60	1.0

		3TNE78A 3TNE82A		3/4TNE82, 3/4TNE84(T), 3/4TNE88	
		Standard	Wear limit	Standard	Wear limit
Valve sinking depth	Intake valve	0.296 ~0.496	1.0	0.306 ~0.506	1.0
	Exhaust valve	0.3~0.5	1.0	0.3~0.5	1.0

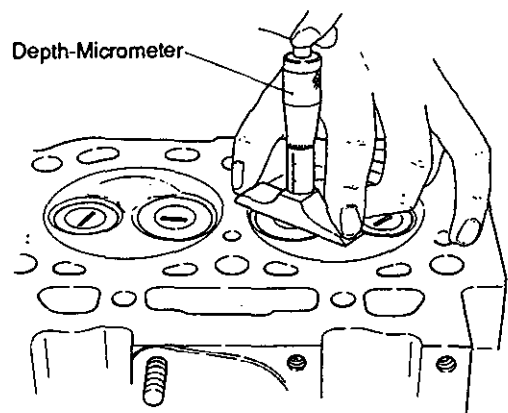

(Measuring the valve sinkage)

- (3) Visually check to see if the combustion surface is free from discoloration, cracks, and crazing. In addition, use the color check kit for cracks and crazing.



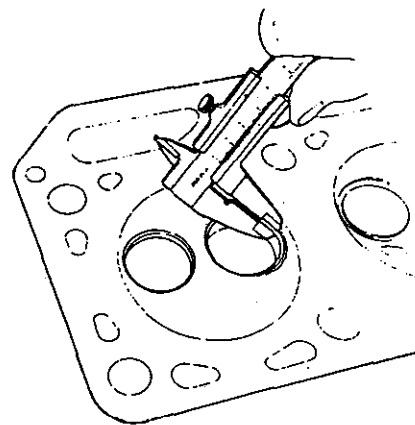
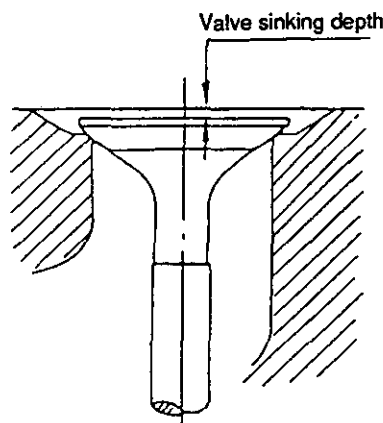

(Measuring the valve seat width)

**(2) Width and angle of the valve seat**

Remove carbon deposits from the seat surface. Measure width and angle of the seat using vernier calipers and an angle gauge.

(mm)

		2/3TNE68		3TNE74	
		Standard	Wear limit	Standard	Wear limit
Valve seat width	Intake	1.15	1.65	1.44	1.98
	Exhaust	1.41	1.91	1.77	2.27
Valve seat angle	Intake	120°	—	120°	—
	Exhaust	90°	—	90°	—

		3TNE78A 3TME82A		3/4TNE82, 3/4TNE84(T), 3/4TNE88	
		Standard	Wear limit	Standard	Wear limit
Valve seat width	Intake	1.36 ~1.53	1.98	1.07 ~1.24	1.74
	Exhaust	1.66 ~1.87	2.27	1.24 ~1.45	1.94
Valve seat angle	Intake	120°	—	120°	—
	Exhaust	90°	—	90°	—

**[Valve Seat Correction Procedure]**

- (1) When the seat surface is worn or roughened slightly, lap the seat surface with a valve compound mixed with oil to a smooth state.
- (2) When the seat surface is worn or roughened heavily, correct seat surface using a seat grinder or seat cutter, and finish it according to step (1).

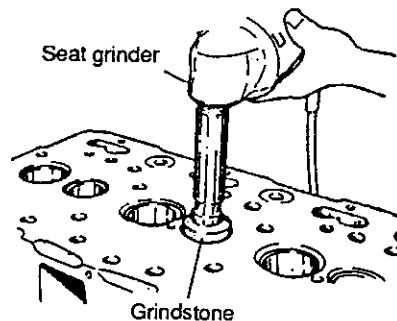

**[Procedure for Using The Seat Grinder and Seat Cutter]**

- (1) Correct the roughened seat surface with a seat grinder or seat cutter.

Seat grinder	Angle (θ)
Intake valve	30°
Exhaust valve	45°

- (2) When the seat width is enlarged from the initial value, correct it by grinding the seat surface with a 70° seat grinder or seat cutter. Then, grind the seat to the standard width with a 15° grinder.

\* When using a seat cutter, evenly apply pressure taking care of avoiding uneven cutting.

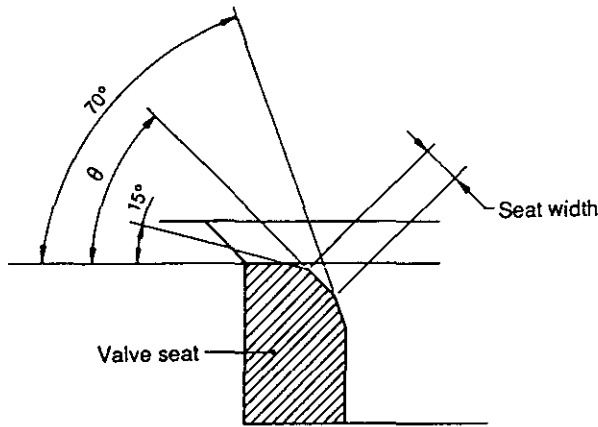

(Valve seat correction angle)

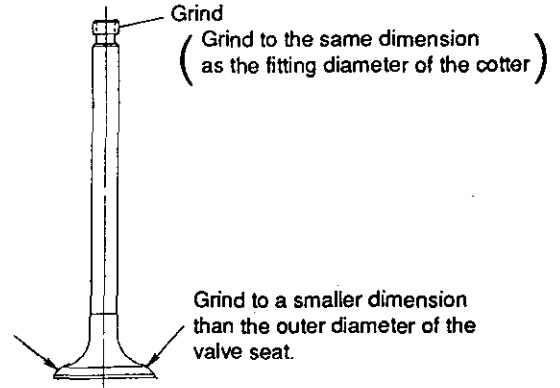

(3) Knead valve compound with oil and finish the valve seat by lapping.

\* If any valve requires correction, be sure to measure the oil clearance between the valve stem outside dia. and valve guide inside dia. If the oil clearance exceeds the limit, replace the valve or valve guide before correcting the valve seat surface. (For oil clearance between the valve and valve guide, refer to section 3 in this chapter.)

(4) Finally, lap the valve using only oil.

\* 1. After the valve seat is corrected, thoroughly clean the valve and cylinder head using diesel oil or the like. Thoroughly remove the valve compound or grindstone powder.  
2. For slightly poor contact, take steps (3) and (4).

Weld the valve with valve seat at three positions

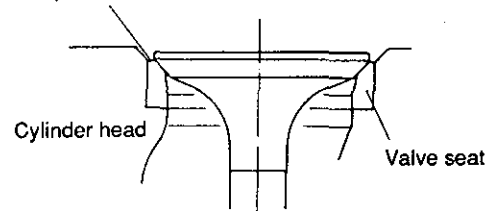

[Insertion of valve seat]

- (1) Put the valve seat in a container which contains liquefied nitrogen, or ether or alcohol with dry ice to cool it sufficiently.
- (2) Heat the cylinder head around the portion for valve seat insertion to 80~100°C with a dryer.
- (3) With the new intake/exhaust valve, securely insert the sufficiently cooled valve seat into the cylinder head by tapping the head of the intake/exhaust valve.
- (4) Stand the cylinder head until the entire cylinder head is cooled to normal temperature.

[Extraction of Valve seat]

Without valve seat	2/3TNE68:	All
	3 TNE74:	VM
	Direct injection system:	CL and VM
With valve seat	3TNE74 (IDI):	CH and VH
	Direct injection system:	CH and VH
	Turbocharged engine:	All

- (1) Grind the circumference of the intake/exhaust valve head being or having been used to the dimension smaller than the valve seat outer diameter.
- (2) Grind the circumference of the stem end of the valve to the same dimension as the fitting diameter of the cotter.
- (3) Weld the intake/exhaust valve head with the valve seat at three positions.
- (4) Hit the stem end of the intake/exhaust valve to extract the valve seat.

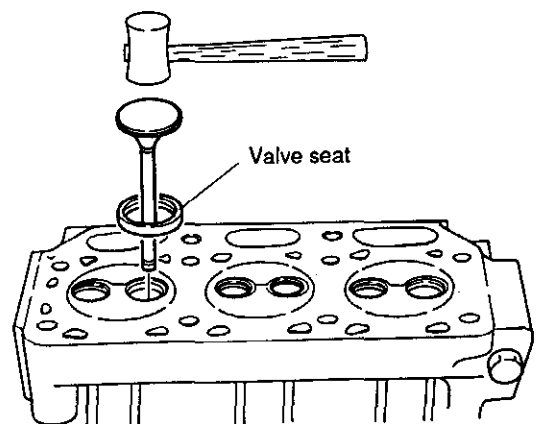

(Insertion of valve seat)

3. Intake/exhaust valve

(1) Wear and bend of the valve stem

Replace a valve stem if bent or worn badly. In this case, replace the valve guide at the same time.

(2) Valve stem and valve guide

Oil clearance is a difference between the valve guide inside diameter measured with a three-point micrometer (capable of measuring inside diameter between 4 mm and 8 mm) or a cylinder gauge (capable of measuring 6 mm or greater inside diameter) and the stem outside diameter measured with a micrometer. When oil clearance is near the limit, replace both the intake/exhaust valve and valve guide with new ones.

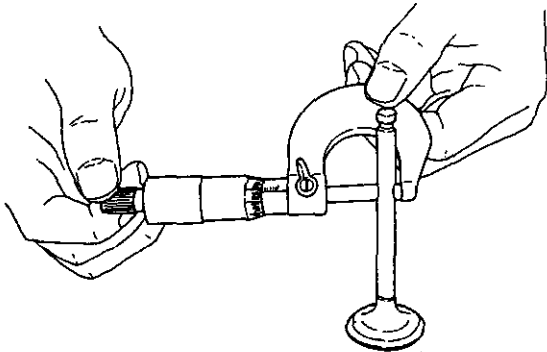

(Measuring the valve stem outside diameter)

(mm)

		2/3TNE68		3TNE74	
		Standard	Wear limit	Standard	Wear limit
Intake valve	Stem O.D.	5.460 ~5.475	5.4	6.960 ~6.975	6.9
	Guide I.D.	5.500 ~5.515	5.58	7.005 ~7.020	7.08
	Oil clearance	0.025 ~0.055	0.18	0.030 ~0.060	0.18
Exhaust valve	Stem O.D.	5.445 ~5.460	5.4	6.945 ~6.960	6.9
	Guide I.D.	5.500 ~5.515	5.58	7.005 ~7.020	7.08
	Oil clearance	0.040 ~0.070	0.18	0.045 ~0.075	0.18

		3TNE78A 3TNE82A		3/4TNE82, 3/4TNE84(T), 3/4TNE88	
		Standard	Wear limit	Standard	Wear limit
Intake valve	Stem O.D.	6.945 ~6.960	6.9	7.955 ~7.975	7.9
	Guide I.D.	7.000 ~7.015	7.08	8.010 ~8.025	8.1
	Oil clearance	0.040 ~0.070	0.18	0.035 ~0.070	0.2
Exhaust valve	Stem O.D.	6.940 ~6.955	6.9	7.955 ~7.970	7.9
	Guide I.D.	7.015 ~0.045	7.08	8.015 ~8.030	8.1
	Oil clearance	0.045 ~0.075	0.18	0.045 ~0.075	0.2

(3) Thickness of valve head

Measure the thickness of the valve head with a micrometer.

When the measured value is near the wear limit, replace the valve with a new one.

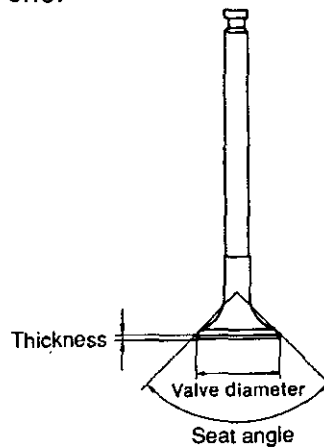

(mm)

		2/3TNE68		3TNE74	
		Standard	Wear limit	Standard	Wear limit
Thick-ness of valve head	Intake valve	0.85 ~1.15	0.50	0.99 ~1.29	0.50
	Exhaust Valve	0.95 ~1.25		0.95 ~1.25	

		3TNE78A 3TNE82A		3/4TNE82, 3/4TNE84(T), 3/4TNE88	
		Standard	Wear limit	Standard	Wear limit
Thick-ness of valve head	Intake valve	1.244 ~1.444	0.50	1.244 ~1.444	0.50
	Exhaust Valve	1.35 ~1.55		1.35 ~1.55	

**[Replacing the Valve Guide]**

(1) Extract the valve guide from the cylinder head using the valve guide extraction tool.

\* For the valve guide extraction tool, refer to Chapter 5, 5-1.

(2) In a container containing liquefied nitrogen, ether or alcohol together with dry ice, put the valve guide to cool it. Then hit the sufficiently cooled valve guide to fit into the cylinder head using the valve guide insertion tool.

\* For the valve guide insertion tool, refer to Chapter 5, 5-1.

(3) After inserting the valve guide, finish the inside of the valve guide with a reamer.

(4) Check the projection of the valve guide.

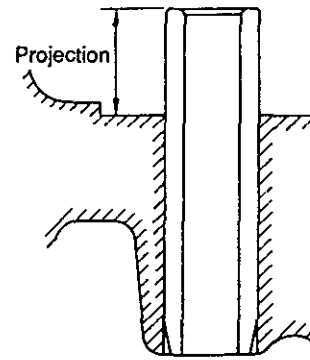

(Valve guide projection)

**4. Valve stem seal**

**[Time of Replacement]**

- (1) When oil loss is found excessive
- (2) When the valve stem seal is removed
- (3) When intake/exhaust valves are removed

**[Precautions on Installation]**

Make sure that the entire surface of valve stem is smooth, and sufficiently apply lubricating oil to the valve stem before reassembling intake/exhaust valves.

(mm)

	2/3TNE68		3TNE74	
	Standard	Wear limit	Standard	Wear limit
Valve guide projection	7	—	9	—

	3TNE78A 3TNE82A		3/4TNE82, 3/4TNE84(T), 3/4TNE88	
	Standard	Wear limit	Standard	Wear limit
Valve guide projection	12	—	15	—

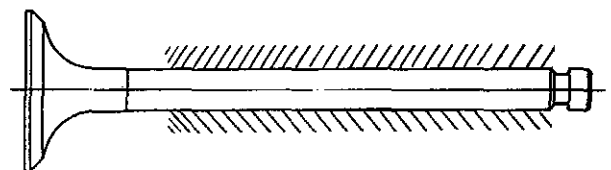
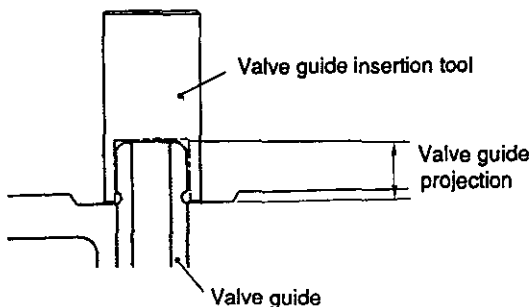
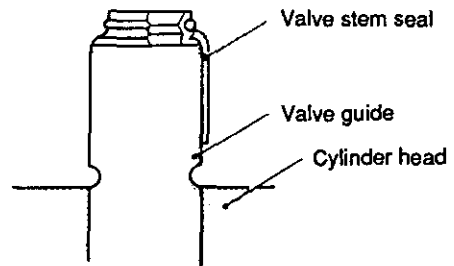

( Hatched portion indicates where to apply lubricating oil. )

5. Checking the valve spring

- (1) Visually check to see if the valve spring is free from flaws and corrosion.
- (2) Measure the free length (length of the spring) and inclination (squareness of the side of the coil).

(mm)

		2/3TNE68		3TNE74	
		Standard	Wear limit	Standard	Wear limit
Valve spring	Free length	28	—	37.4	—
	Inclination	—	0.8	—	1.0
	Tension (kg) (when compressed to by 1 mm)	1.14 ~1.40	—	*2.37/ 1.87	—

\* Tension at variable pitch.

		3TNE78A 3TNE82A		3/4TNE82, 3/4TNE84(T), 3/4TNE88	
		Standard	Wear limit	Standard	Wear limit
Valve spring	Free length	44.4	—	42	—
	Inclination	—	1.1	—	1.1
	Tension (kg) (when compressed to by 1 mm)	*3.61 /2.71	—	*2.36 /3.101	—

\* Tension at variable pitch.

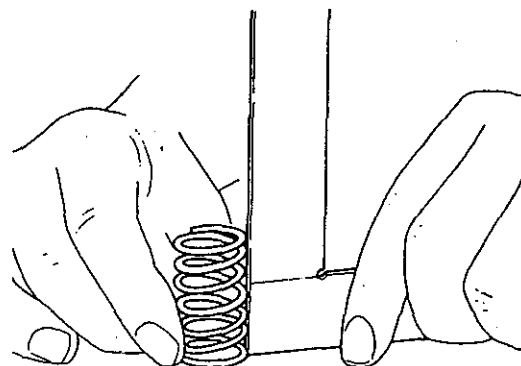

(Measuring the valve spring inclination)

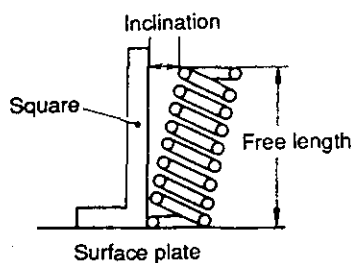

(Measuring the inclination of valve spring)

6. Checking valve spring holder and cotter

Check contact of the inner surface of the valve spring holder with the circumference of the cotter as well as contact of the inner circumference of the cotter with the notch on the head of the valve stem. If such contact is uneven or if the cotter sinks, replace the cotter with a new one.

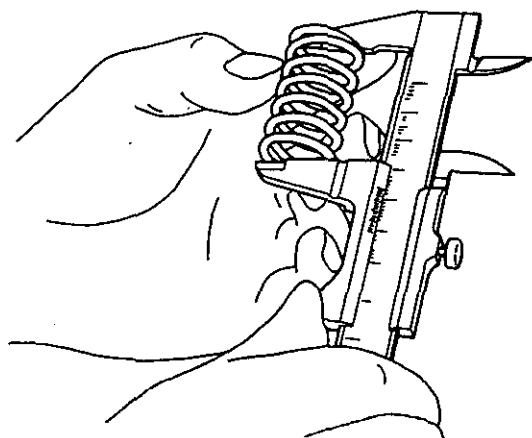

(Measuring the free length)

## 7-2. Cylinder block

### 1. Checking the cylinder block

- (1) Visually check to see if the cylinder block is free from water leak, oil leak and cracks. If any cylinder block is suspected to be cracked, check it by color check.
- (2) Replace the cylinder block if badly damaged and incorrectable.
- (3) Thoroughly clean each oil hole. Make sure that it is not clogged.

### 2. Measuring the bore and distortion of the cylinder

Measure the bore of each cylinder with a cylinder gauge. Measure the cylinder at point a, approx. 20 mm below the crest of the liner, and at points b and c at equal pitch (a-b = b-c).

Obtain distortion (roundness and cylindricity of each cylinder) from the measured values as follows:

- Roundness:  
Difference between max. and min. bore values on the same cross section of each liner.
- Cylindricity:  
Difference between max. and min. bore values in the same direction of each liner.

Honing (honing and boring) is required when the measured value exceeds the limit.

\* For oversized piston and piston ring, refer to this chapter, 7-4, 8.

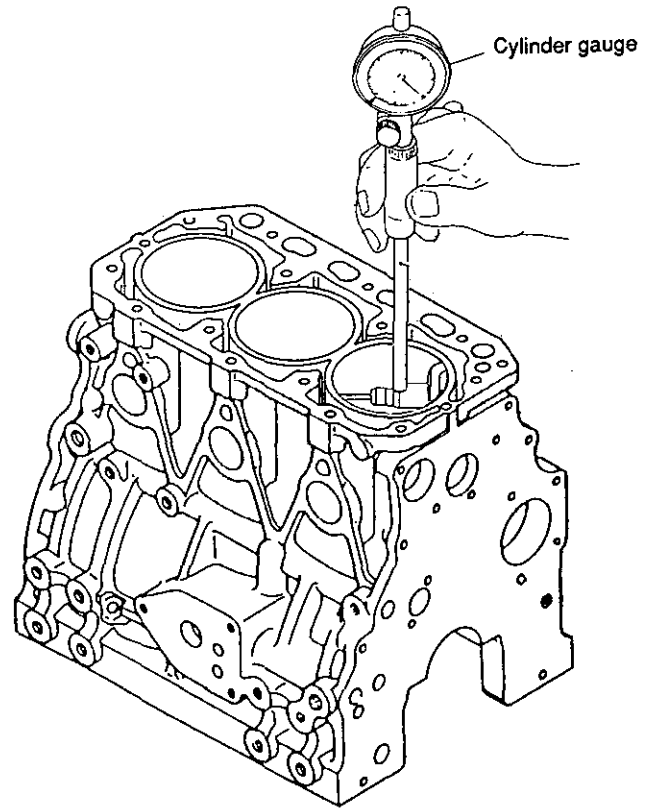

(Measuring the cylinder bore)

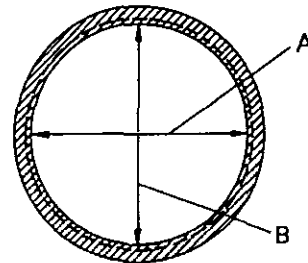
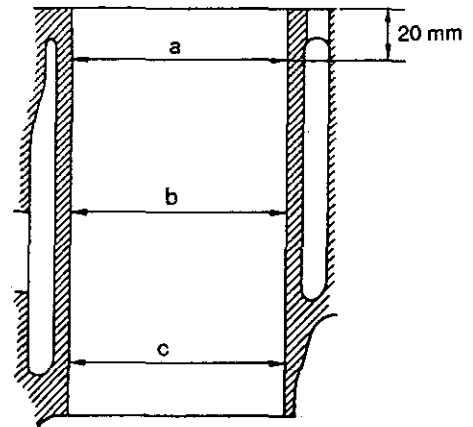

Note: Measurement should be made at a, b and c in the directions of A and B.

(Cylinder bore measuring positions)

(mm)

	2/3TNE68		3TNE74	
	Standard	Wear limit	Standard	Wear limit
Cylinder bore	68.000 ~68.030	68.20	74.000 ~74.030	74.20
Cylinder roundness	0.00 ~0.01	0.03	0.00 ~0.01	0.03
Cylindricity	0.00 ~0.01	0.03	0.00 ~0.01	0.03

	3TNE78A		3TNE82A 3/4TNE82	
	Standard	Wear limit	Standard	Wear limit
Cylinder bore	78.000 ~78.030	78.20	82.000 ~82.030	82.20
Cylinder roundness	0.00 ~0.01	0.03	0.00 ~0.01	0.03
Cylindricity	0.00 ~0.01	0.03	0.00 ~0.01	0.03

	3/4TNE84(T)		3/4TNE88	
	Standard	Wear limit	Standard	Wear limit
Cylinder bore	84.000 ~84.030	84.20	88.000 ~88.030	88.20
Cylinder roundness	0.00 ~0.01	0.03	0.00 ~0.01	0.03
Cylinder cylindricity	0.00 ~0.01	0.03	0.00 ~0.01	0.03

### 3. Honing

#### (1) Practice of honing

Honing or boring the cylinder if unevenly worn, flawed, or otherwise damaged. Slight uneven worn, flaws, etc. may well be only honing with a Flex-Hone. However, significant uneven wear should be first bored and then honed. It is important to take into careful consideration as to whether the cylinder can attain perfect roundness after honing, boring, or both, considering maximum wear. In addition, carefully study as to whether prepared oversized pistons and piston rings are applicable. (For the oversized piston and piston ring, refer to this chapter 7-4, 8.)

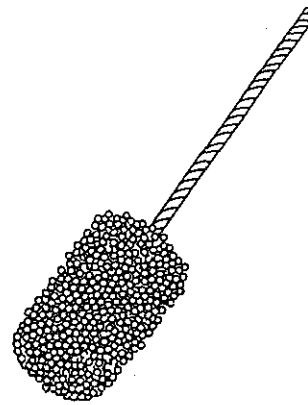

(Flex-Hone)

#### (2) Procedure for using the Flex-Hone

It is common practice to use the Flex-Hone for honing. The procedure for using it appears in the following table. Any material must allow for approx. 1/1000 mm when honed with the Flex-Hone.

#### 1. Necessary items

Flex-Hone, power drill, and honing fluid

Model	Flex-Hone Yanmar code No.	Applicable bore (mm)
2/3TNE68	129400-92400	63~70
3TNE74	129400-92410	70~76
3TNE78A/82A 3/4TNE82 3/4TNE84(T)	129400-92420	76~89
3/4TNE88	129400-92430	83~95

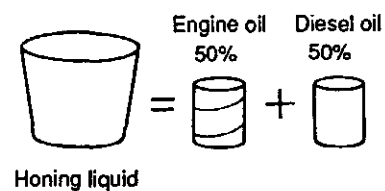
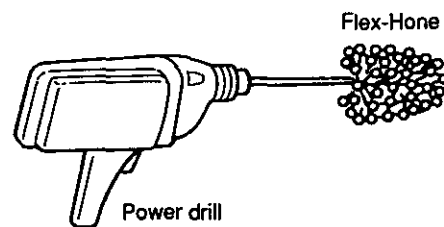

**2. Handling procedure**

Apply the honing fluid to the Flex-Hone. Insert the Flex-Hone into the cylinder while turning it, move it up and down for about 30 sec for a cross hatch angle of 30–40°. Extract the Flex-Hone while turning it.

\* Use the Flex-Hone at a speed of 300–1200 rpm. Use of the Flex-Hone at a higher speed may be hazardous.

\* Never insert into or extract from the cylinder the Flex-Hone, with the power drill left stopped.

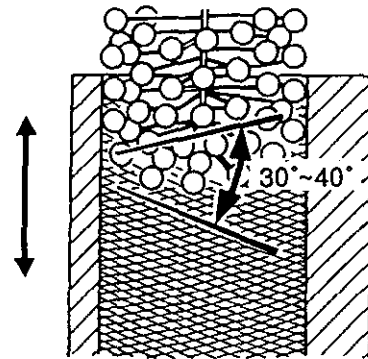

**4. Overhaul of cylinder (Reference)**

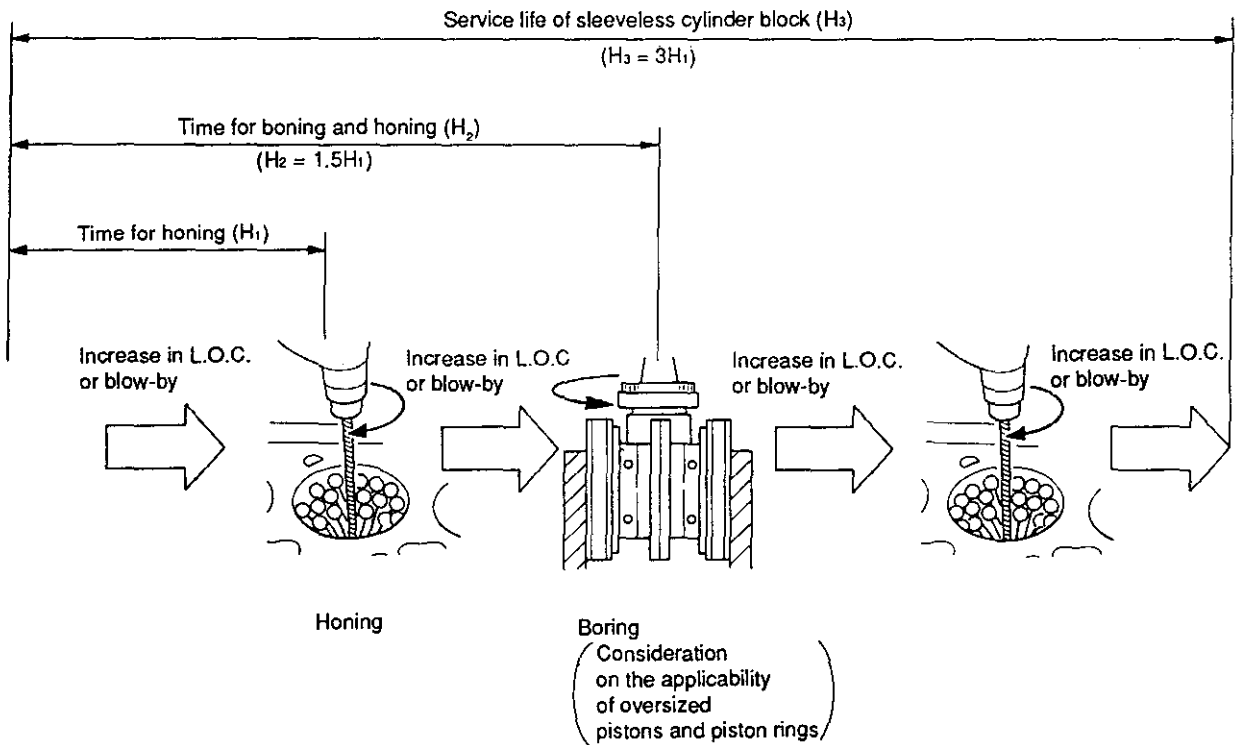



### 7-3. Valve rocker arm

#### 1. Measuring the outside diameter of rocker arm shaft and inside diameter of rocker arm

Oil clearance is the difference between the rocker arm inside diameter measured with a cylinder gauge and the rocker arm shaft outside diameter measured with a micrometer. When the oil clearance is near the limit, replace the rocker arm shaft and rocker arm with new ones.

(mm)

		2/3TNE68		3TNE74		3TNE78A/82A 3/4TNE82, 3/4TNE84(T), 3/4TNE88	
		Standard	Wear limit	Standard	Wear limit	Standard	Wear limit
Intake/exhaust rocker arm	Rocker arm shaft outside diameter	9.972 ~9.987	9.95	11.966 ~11.984	11.95	15.966 ~15.984	15.95
	Rocker arm bushing inside diameter	10.000 ~10.020	10.09	12.000 ~12.020	12.09	16.000 ~16.020	16.09
	Oil clearance	0.013 ~0.048	0.14	0.016 ~0.054	0.14	0.016 ~0.054	0.14

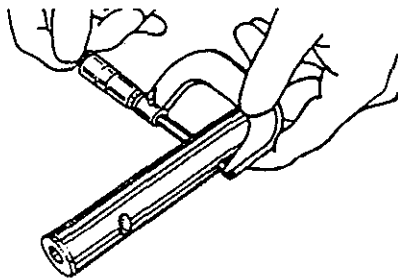

(Measuring the rocker arm shaft outside diameter)

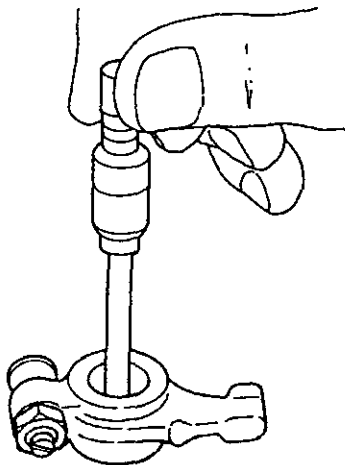

(Measuring the rocker arm inside diameter)

#### 2. Checking push rod bend, measuring tappet outside diameter and checking contact surface

Put the push rod on the stool, and measure the gap between the push rod and stool to make sure the push rod is in close contact with the stool. Also, measure the outside diameter of the tappet with a micrometer.

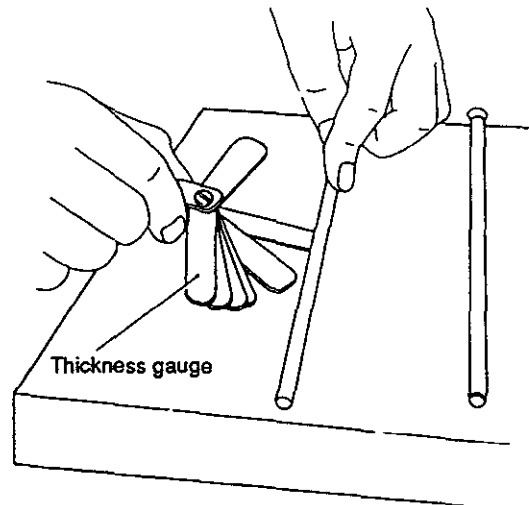

(Measuring the push rod bend)

(mm)

		2/3TNE68		3TNE74		3TNE78A/82A, 3/4TNE82, 3/4TNE84(T), 3/4TNE88	
		Standard	Wear limit	Standard	Wear limit	Standard	Wear limit
Push rod bending		0.03 or less	—	0.03 or less	—	0.03 or less	—
Tappet	Tappet stem outside diameter	17.950 ~17.968	17.93	20.927 ~20.960	20.90	11.975 ~11.990	11.93
	Tappet guide hole inside diameter	18.000 ~18.018	18.05	21.000 ~21.021	21.05	12.000 ~12.018	12.05
	Oil clearance	0.032 ~0.068	0.12	0.040 ~0.094	0.15	0.010 ~0.043	0.12

**3. Other checks**

**(1) Valve rocker arm shaft spring**

Check to see if the rocker arm shaft spring is free from corrosion and wear. If not, replace it with a new one.

**(2) Wear of intake/exhaust valve rocker arm and valve cap**

Check the intake/exhaust valve rocker arm for their contact surfaces with valve cap. If any of them is abnormally worn or partially flaked, replace it.

**(3) Check the portion where the valve clearance adjusting screw is in contact with the push rod. If the portion is worn and flaked, replace the pushrod or adjusting screw.**

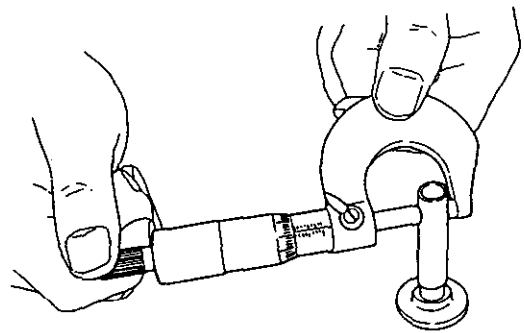

(Measuring the tappet outside diameter)

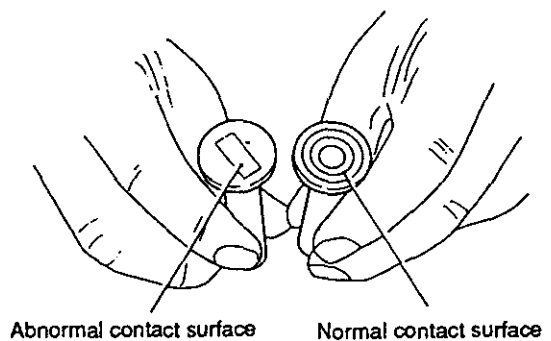
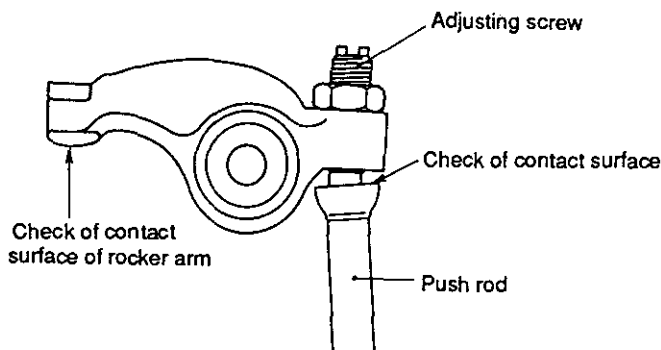

(Checking the tappet contact surface)

### 7-4. Piston and piston ring

#### 1. Checking the piston

- (1) Remove carbon deposits from the head and combustion surface of the piston so as not to impair the piston. Check to see if there is any crack or damage.
- (2) Check the circumference and ring groove of the piston, and replace if worn or damaged.

#### 2. Measuring the piston outside diameter

To measure the piston outside diameter, measure the long diameter of the oval hole in vertical direction to the pin hole and at a position 22–25 mm from the lower end of the piston.

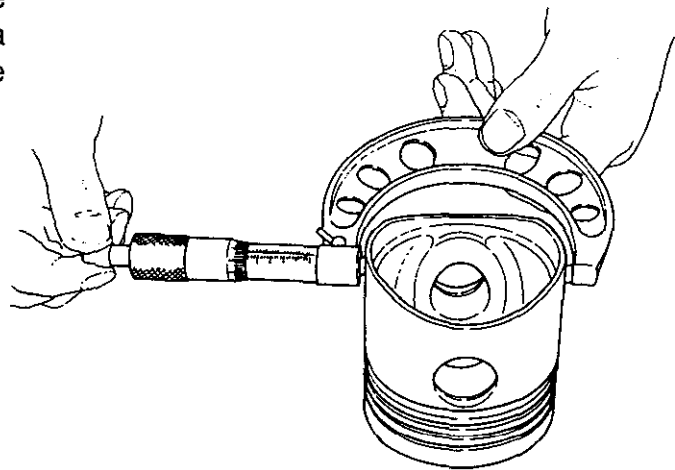
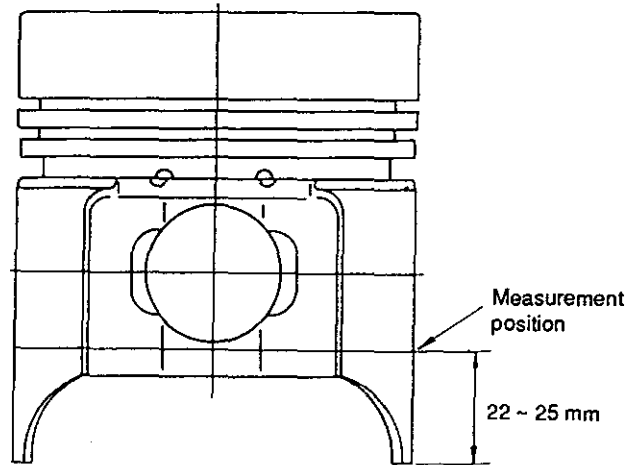

(Measuring the piston outside diameter)

(mm)

	2/3TNE68				3TNE74		3TNE78A		3TNE82A		3/4TNE82		3/4TNE84(T)		3/4TNE88	
	VM, VH		CH		Standard	Wear limit	Standard	Wear limit	Standard	Wear limit	Standard	Wear limit	Standard	Wear limit	Standard	Wear limit
	Standard	Wear limit	Standard	Wear limit												
Piston outside diameter	67.960 ~67.990	67.90	67.940 ~67.970	67.90	73.940 ~73.970	73.90	77.950 ~77.980	77.90	81.950 ~81.980	81.90	81.945 ~81.975	81.90	83.945 ~83.975	83.90	87.945 ~87.975	87.90
Minimum clearance between piston and cylinder	0.025 ~0.055	—	0.045 ~0.075	—	0.045 ~0.075	—	0.035 ~0.065	—	0.035 ~0.065	—	0.040 ~0.070	—	0.040 ~0.070	—	0.040 ~0.070	—

#### 3. Shapes of piston rings

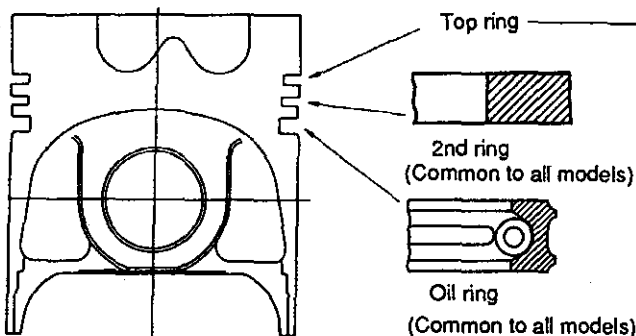

Model	2/3TNE68, 3TNE74
Application	VM, CH, VH
Top ring	

Model	3TNE78A/82A, 3/4TNE84(T) 3/4TNE82, 3/4TNE88
Application	CL, VM   CH, VH, w/turbocharged
Top ring	

**4. Measuring the ring groove width, ring width, and end clearance**

To measure the piston ring groove width, first measure the width of the piston ring. Then, insert the piston ring into the ring groove that has been carefully cleaned. Insert a thickness gauge in between the piston ring and groove to measure the gap between them. Obtain the ring groove width by adding ring width to the measured side clearance.

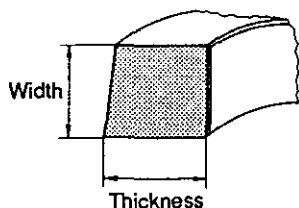

To measure the end clearance, push the piston ring into the sleeve using the piston head, insert a thickness gauge in end clearance to measure. If the sleeve is worn, measure the end clearance after pushing the piston ring to the portion of the sleeve which is less worn (approx. 30 mm from the lower end of the sleeve).

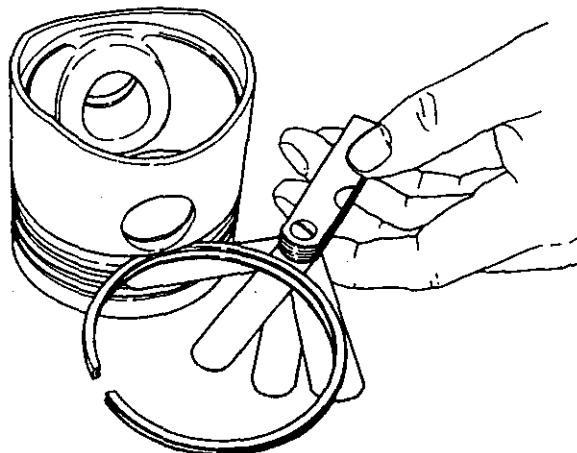

(Measuring the side clearance)

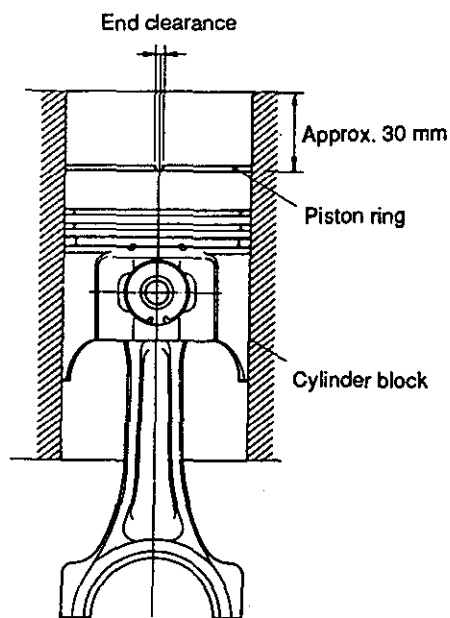
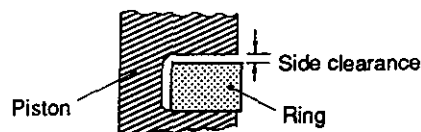

( Measuring the end clearance )  
of piston ring

(mm)

		2/3TNE68		3TNE74		3TNE78A		3TNE82A, 3/4TNE82, 3/4TNE84(T)		3/4TNE88	
		Standard	Wear limit	Standard	Wear limit	Standard	Wear limit	Standard	Wear limit	Standard	Wear limit
Top ring	Ring groove width	1.550 ~1.570	—	1.550 ~1.570	—	2.035 ~2.050	—	2.065 ~2.080	—	2.060 ~2.075	—
	Ring width	1.470 ~1.490	—	1.470 ~1.490	—	1.940 ~1.960	—	1.970 ~1.990	—	1.970 ~1.990	—
	Min. side clearance	0.060 ~0.100	—	0.060 ~0.100	—	0.075 ~0.110	—	0.075 ~0.110	—	0.070 ~1.105	—
	End clearance	0.100 ~0.250	1.5	0.200 ~0.400	1.5	0.200 ~0.400	1.5	0.200 ~0.400	1.5	0.200 ~0.400	1.5
2nd ring	Ring groove width	1.540 ~1.555	—	1.520 ~1.535	—	2.025 ~2.040	—	2.035 ~2.050	—	2.025 ~2.040	—
	Ring width	1.430 ~1.450	—	1.410 ~1.430	—	1.975 ~1.990	—	1.970 ~1.990	—	1.970 ~1.990	—
	Min. side clearance	0.090 ~0.125	—	0.090 ~0.125	—	0.035 ~0.065	—	0.045 ~0.080	—	0.035 ~0.070	—
	End clearance	0.150 ~0.350	1.5	0.200 ~0.400	1.5	0.250 ~0.400	1.5	0.200 ~0.400	1.5	0.200 ~0.400	1.5
Oil ring	Ring groove width	3.010 ~3.025	—	3.010 ~3.025	—	3.015 ~3.030	—	4.015 ~4.030	—	4.015 ~4.030	—
	Ring width	2.970 ~2.990	—	2.970 ~2.990	—	2.970 ~2.990	—	3.970 ~3.990	—	3.970 ~3.990	—
	Min. side clearance	0.020 ~0.055	—	0.020 ~0.055	—	0.025 ~0.060	—	0.025 ~0.060	—	0.025 ~0.060	—
	End clearance	0.150 ~0.350	1.5	0.150 ~0.350	1.5	0.200 ~0.400	1.5	0.200 ~0.400	1.5	0.200 ~0.400	1.5

5. Reassembly of piston ring

- Using the piston ring replacer, insert the piston ring into the ring groove, with the manufacturer's mark near the joint of the piston ring facing up to the combustion chamber side. After fitting the piston ring, make sure that the piston ring moves freely.

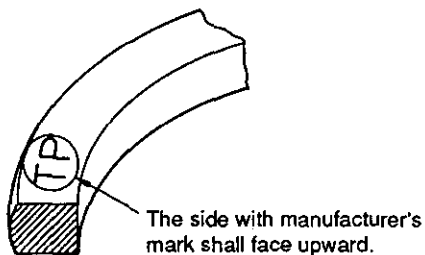

- Stagger the piston rings joints at 120° intervals, making sure that they are not aligned along the piston. Apply lube oil to the circumference of the piston.

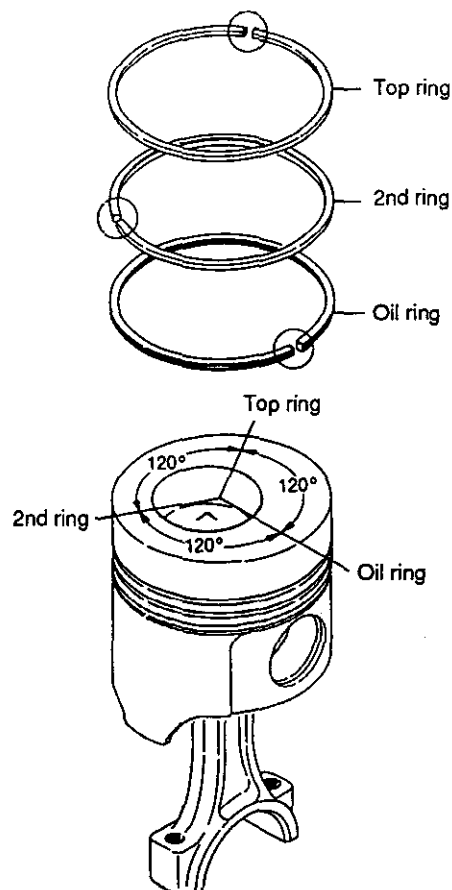

**6. Measuring the outside diameter of the piston pin and the pin hole diameter**

Measure outside diameter of the piston pin and pin hole diameter. Replace the piston pin if the wear limit is exceeded.

Apply lubricating oil to the piston pin before inserting it into the piston.

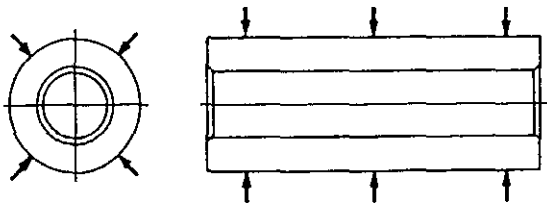

(Measuring point of the piston pin O. D.)

(mm)

		2/3TNE68		3TNE74	
		Standard	Wear limit	Standard	Wear limit
Piston and piston pin	Piston pin outside diameter	19.991 ~20.000	19.90	20.991 ~21.000	20.90
	Piston pin hole dia.	20.000 ~20.008	20.02	21.000 ~21.008	21.02
	Oil clearance	0.000 ~0.017	0.12	0.000 ~0.017	0.12

		3TNE78A 3TNE82A		3/4TNE82, 3/4TNE84(T), 3/4TNE88	
		Standard	Wear limit	Standard	Wear limit
Piston and piston pin	Piston pin outside diameter	22.991 ~23.000	22.90	25.987 ~26.000	25.90
	Piston pin hole dia.	23.000 ~23.008	23.02	26.000 ~26.009	26.02
	Oil clearance	0.000 ~0.017	0.12	0.000 ~0.022	0.12

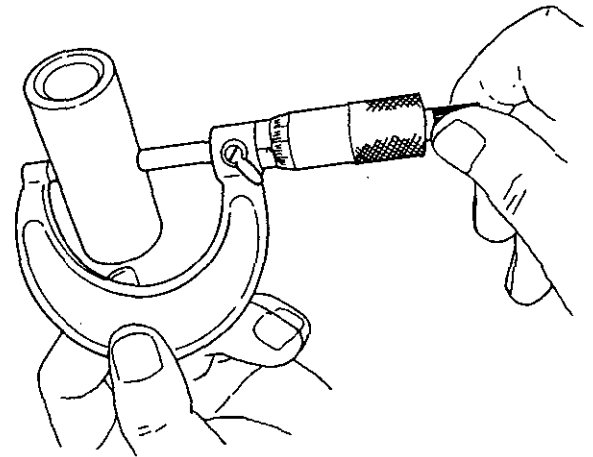

(Measuring the piston pin outside diameter)

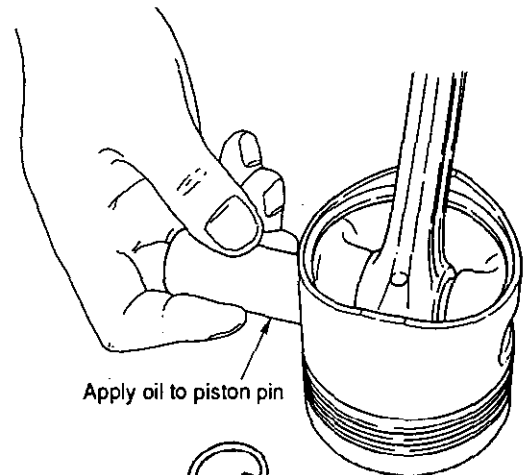

Apply oil to piston pin

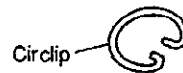

(Insertion of piston pin)

**7. [Reference] Top clearance**

(mm)

	2/3TNE68		3TNE74	
	Standard	Wear limit	Standard	Wear limit
Top clearance	0.610 ~0.730	—	0.658 ~0.778	—

	3TNE78A 3TNE82A		3/4TNE82, 3/4TNE84(T), 3/4TNE88	
	Standard	Wear limit	Standard	Wear limit
Top clearance	0.650 ~0.770	—	0.660 ~0.780	—

**8. List of the oversized piston and piston ring**

(0.250S: Oversized by 0.25 mm)

Model		Size classification	Piston assy code (including piston ring assy)	Piston ring assy code
2/3TNE68	VM VH	0.250S	119265—22930	119265—22950
	CH	0.250S	119265—22900	
3TNE74	VM CH VH	0.250S	119623—22900	119623—22950
3TNE78A	CL VM CH VH	0.250S	119818—22910	119818—22950
3TNE82A	CL VM	0.250S	119813—22900	129003—22950
3/4TNE82	CL VM	0.250S	129003—22900	129003—22950
	CH VH	0.250S	129003—22910	129003—22950
3/4TNE84(T)	CL VM	0.250S	129002—22900	129002—22950
	CH VH	0.250S	129002—22910	129002—22950
3/4TNE88	CL VM	0.250S	129001—22900	129001—22950

## 7-5. Connecting rod

### 1. Visual inspection

Inspect the portion near the boundary of the chamfered portion and I-beam section of the big and small ends of the connecting rod as well as the portion near the oil hole of the bushing at the small end for cracks, deformation, and discoloration.

### 2. Measuring the twist and parallelism

Measure the twist and parallelism by use of the connecting rod aligner.

(mm)

	All models	
	Standard	Wear limit
Twist and parallelism	0.03 or less per 100 mm	0.08

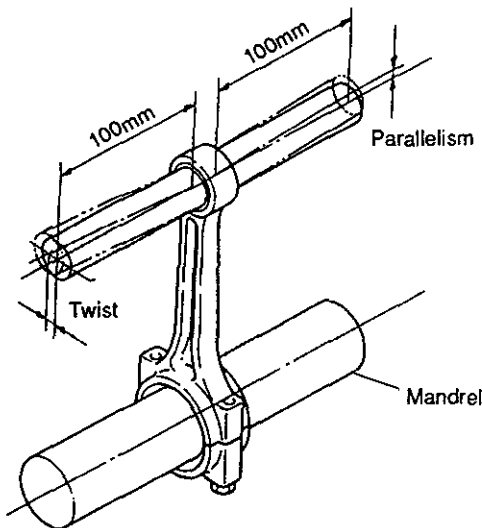

(Measuring the twist and parallelism)

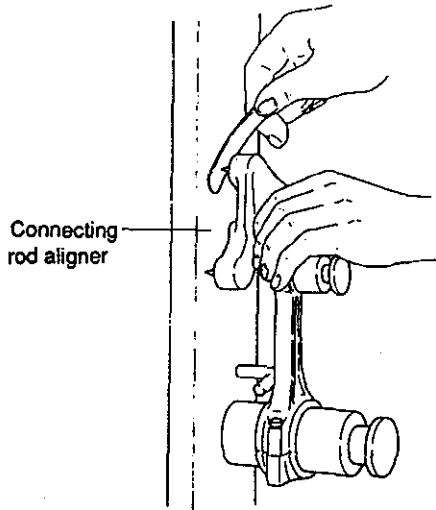

(Measuring the twist with connecting rod aligner)

### 3. Measuring the crankpin and bushing clearance

To measure the oil clearance of the crankpin and bushing, measure the inside diameter of the crankpin metal and outside diameter of the crankpin, and obtain the difference between them.

If the measured oil clearance exceeds or near the wear limit, replace the crankpin metal. If the crankpin is excessively or unevenly worn, grind the crankpin, and use an oversized crankpin metal.

\* To measure the inside diameter of the crankpin metal, reassemble the crankpin metal to the connecting rod and tighten the rod bolt to the specified torque, making sure each metal is fitted on the correct position.

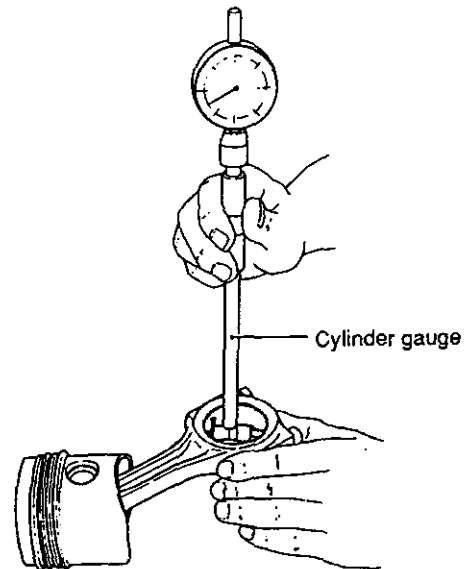

( Measuring the inside diameter of the crankpin metal )

(kgf-m)

	2/3TNE68 3TNE74	3TNE78A 3TNE82A	3/4TNE82, 3/4TNE84(T), 3/4TNE88
	Specified torque		
Rod bolt tightening torque (Apply lube oil to the rod bolt)	2.3-2.8	3.8-4.2	4.5-5.5



(mm)

		2/3TNE68		3TNE74		3TNE78A 4TNE82A		3/4TNE82, 3/4TNE84(T), 3/4TNE88	
		Standard	Wear limit	Standard	Wear limit	Standard	Wear limit	Standard	Wear limit
Crankpin side	Crankpin bushing inside dia.	39.000 ~39.016	—	43.000 ~43.016	—	46.000 ~46.016	—	51.000 ~51.010	—
	Crankpin metal thickness	1.487 ~1.500	—	1.487 ~1.500	—	1.487 ~1.500	—	1.492 ~1.500	—
	Crankpin outside diameter	35.970 ~35.980	35.91	39.970 ~39.980	39.91	42.952 ~42.962	42.91	47.952 ~47.962	47.91
	Oil clearance	0.033 ~0.059	0.15	0.033 ~0.059	0.15	0.038 ~0.0900	0.16	0.038 ~0.074	0.16

**4. Measuring the oil clearance between the piston pin bushing and piston pin**

To measure of oil clearance between the piston pin bushing and piston pin, measure the inside diameter of the piston pin bushing and outside diameter of the piston pin, and obtain the difference between them.

(mm)

		2/3TNE68		3TNE74	
		Standard	Wear limit	Standard	Wear limit
Piston pin side	Piston pin bushing inside diameter	20.025 ~20.038	20.10	21.025 ~21.038	21.10
	Piston pin outside diameter	19.991 ~20.000	19.90	20.991 ~21.000	20.90
	Oil clearance	0.025 ~0.047	0.2	0.025 ~0.047	0.2

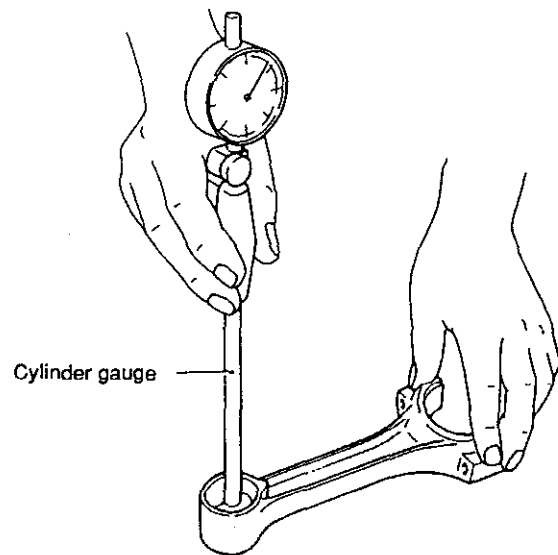

( Measuring the inside diameter of the piston pin bushing )

		3TNE78A 3TNE82A		3/4TNE82, 3/4TNE84(T), 3/4TNE88	
		Standard	Wear limit	Standard	Wear limit
Piston pin side	Piston pin bushing inside diameter	23.025 ~23.038	23.10	26.025 ~26.038	26.10
	Piston pin outside diameter	22.991 ~23.000	22.90	25.987 ~26.000	25.90
	Oil clearance	0.025 ~0.047	0.2	0.025 ~0.051	0.2

**5. Checking the crankpin metal for contact**

Apply a blue ink or a minium to the crankpin metal upper surface. Attach the crankpin metal to the connecting rod, and tighten the rod bolt to the crankshaft to the specified torque (Refer to this section 3) to check the metal for contact. If the contact surface occupies 75% or more of the total surface, the crankpin metal is acceptable in terms of contact.

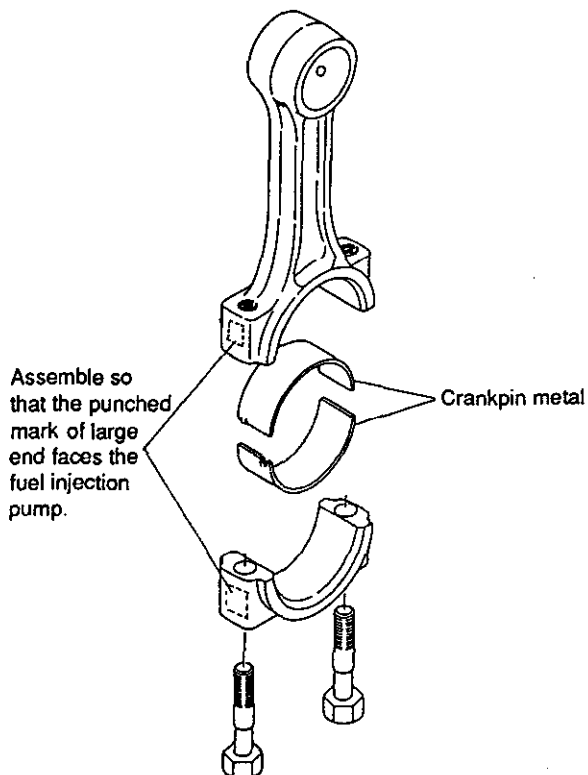

**6. Assembling the piston and connecting rod**

Assemble the piston with the connecting rod, with the mark at the big end of the connecting rod facing the fuel injection pump. Reassemble the piston so that the recess of the combustion chamber is on the side of the fuel injection pump as seen from the top.

**(Direct injection system piston)**

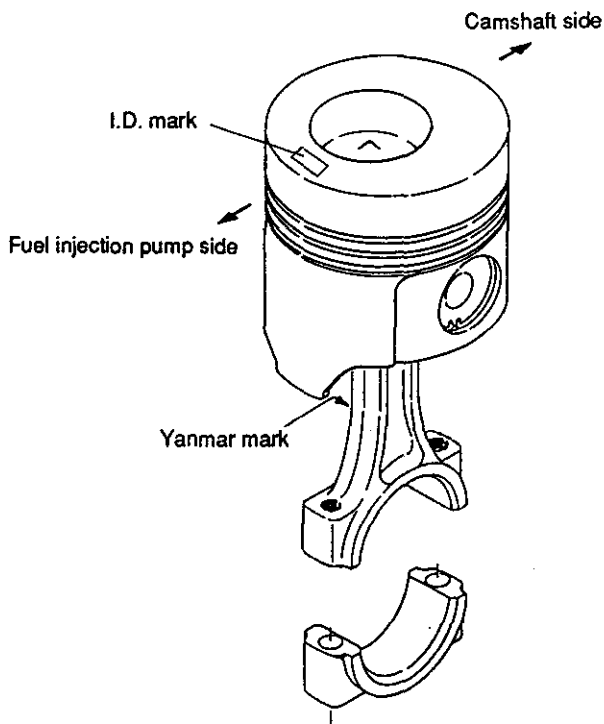

**(Indirect injection system piston)**

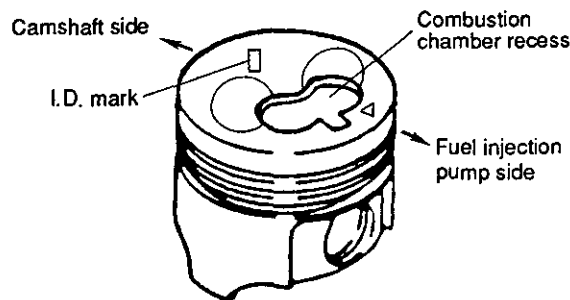

**7. Side gap of the connecting rod**

After attaching the connecting rod to the crankshaft, tighten the rod bolt to the specified torque (see this section 3). Measure the side gap by inserting a thickness gauge into the side gap. If the standard is exceeded, replace the crankpin metal or connecting rod.

(mm)

	All models
Side gap	0.2~0.4

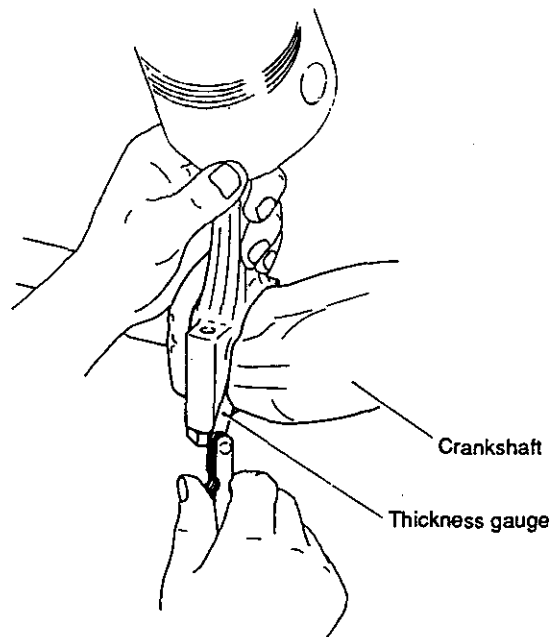

**(Measuring the connecting rod side gap)**

8. Oversized crankpin metal

(0.25mm, oversized)

	Crankpin metal	
	Part code No.	Metal thickness (mm)
		Standard
2/3TNE68	119260—23350	1.625
3TNE74	119620—23350	1.625
3TNE78A/82A	119810—23350	1.625
3/4TNE82 3/4TNE84(T) 3/4TNE88	129150—23350	1.625

7-6. Camshaft

1. Camshaft side gap

Before extracting the camshaft, bring a dial gauge into contact with the camshaft gear and measure the side gap around the camshaft. If the measured value exceeds the limit, replace the thrust metal with a new one.

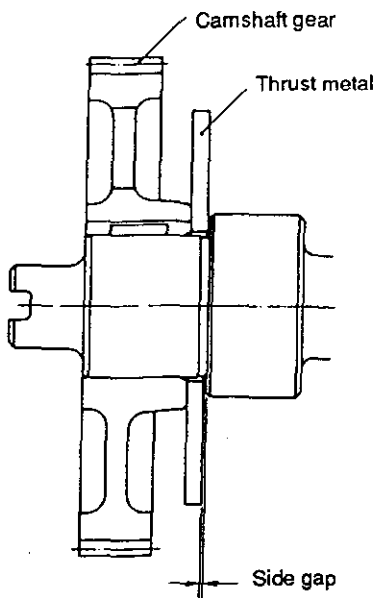

(mm)

	All models
Side gap	0.05~0.25

2. Checking the camshaft for appearance

Check the camshaft for the contact surface of the tappet to the cam, seizure and wear of the bearing, and damage of the cam gear.

3. Measuring the bend of the camshaft

Support the camshaft with V blocks. Using a dial gauge, measure the runout of the journal at the center of the camshaft, while rotating the camshaft.

Take 50% of the measured runout as bend.

(mm)

	All models	
	Standard	Wear limit
Camshaft bend	0.02 or less	0.05

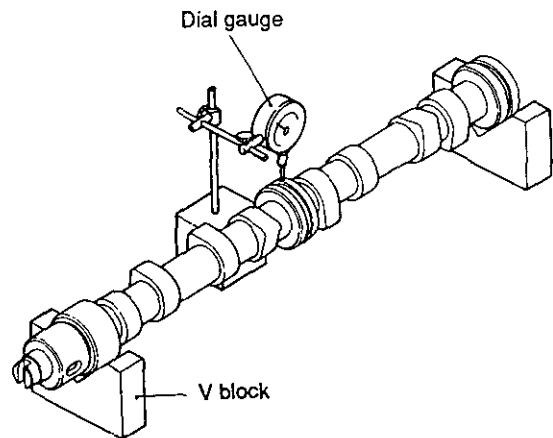

(Measuring the camshaft bend)

4. Measuring the intake/exhaust cam height

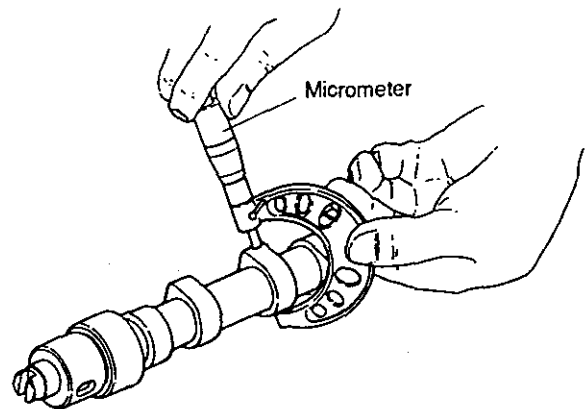

(Measuring the cam height)

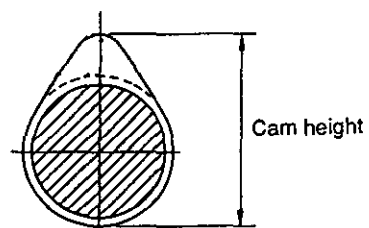

(mm)

		2/3TNE68		3TNE74		3TNE78A/82A, 3/4TNE82, 3/4TNE84(T), 3/4TNE88	
		Standard	Wear limit	Standard	Wear limit	Standard	Wear limit
Cam height	Intake cam	29.970 ~30.030	29.75	33.950 ~34.050	33.75	38.635 ~38.765	38.40
	Exhaust cam	29.970 ~30.030	29.75	33.950 ~34.050	33.75	38.635 ~38.765	38.40

**5. Measuring the outside diameter of the camshaft bearing**

Measure the outside diameter of the camshaft with a micrometer. Calculate the oil clearance from measured camshaft outside diameter and the camshaft bushing inside diameter measured with a cylinder gauge after inserting the camshaft bushing into the cylinder block.

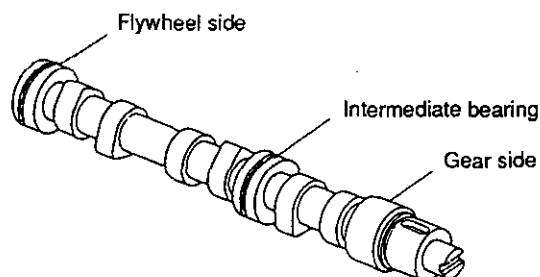

(mm)

		2/3TNE68		3TNE74		3TNE78A/82A, 3/4TNE82, 3/4TNE84(T), 3/4TNE88	
		Standard	Wear limit	Standard	Wear limit	Standard	Wear limit
Gear side	Camshaft journal outside diameter	35.940 ~35.960	35.85	39.940 ~39.960	39.85	44.925 ~44.950	44.85
	Oil clearance	0.040 ~0.085	—	0.040 ~0.085	—	0.040 ~0.130	—
Intermediate	Camshaft journal outside diameter	35.910 ~35.935	35.85	39.910 ~39.935	39.85	44.910 ~44.935	44.85
	Oil clearance	0.065 ~0.115	—	0.065 ~0.115	—	0.065 ~0.115	—
Flywheel side	Camshaft journal outside diameter	35.940 ~35.960	35.85	39.940 ~39.960	39.85	44.925 ~44.950	44.85
	Oil clearance	0.040 ~0.125	—	0.040 ~0.125	—	0.040 ~0.100	—

**6. Extracting the camshaft bushing**

Extract the bushing with camshaft bushing tool (refer to Chapter 5, 5-1.)

## 7-7. Crankshaft

### 1. Side gap around the crankshaft

Before extracting the crankshaft and when reassembling it, bring a dial gauge into contact to the end of the crankshaft. Force the crankshaft to both sides in the axial direction to measure the thrust gap. Alternatively, insert a thickness gauge directly into a thrust gap between the thrust metal in the standard part and crankshaft to measure the side gap.

If the limit is exceeded, replace the thrust metal with a new one.

(mm)

	All models
Thrust gap	0.090~0.271

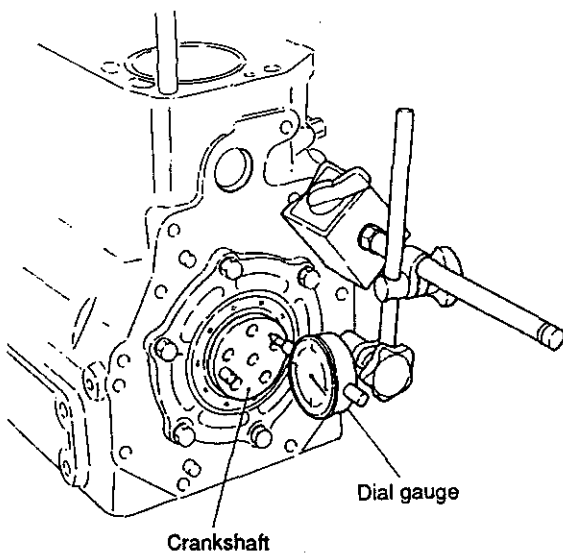

### 2. Color check of crankshaft

Clean the crankshaft and check it using a color check kit or a magnaflux inspector. Replace the crankshaft if cracked or badly damaged. If the crankshaft is slightly damaged, correct it by re-grinding.

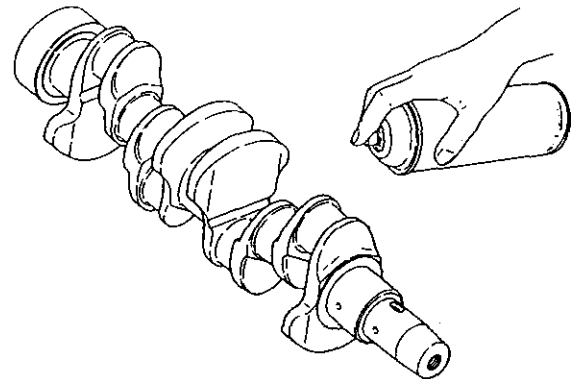

(Color check Inspection)

### 3. Checking the metal

Check the metal for flaking, melting, seizure, and the state of the contact face. Replace the metal if found defective.

### 4. Bend of the crankshaft

Support the crankshaft with V-blocks at both ends of the journals; measure the runout at the center journal with a dial gauge while rotating the crankshaft to check the extent of crankshaft bend.

(mm)

	All models
	Standard
Bend	0.02 or less

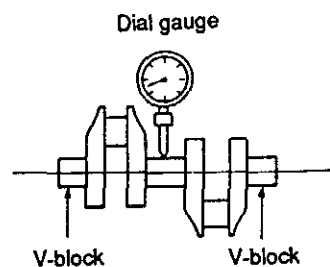
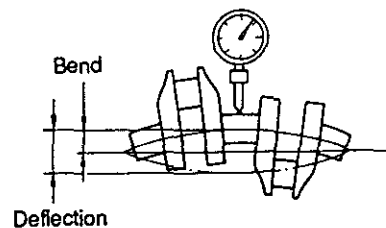

(Measuring the crankshaft bend)

**5. Measurement of crankpin and journal**

Measure the outside diameter, roundness, taper angle of the crankpin and the journal. If uneven wear or roundness exceeds the wear limit but measured outside diameter is within the limit, use the crankpin and journal after correcting them by regrinding. Replace them with new ones, if any of the limit is exceeded.

An oversized crankpin metal by 0.25 mm is available. (See this Chapter 7-5, 8.)

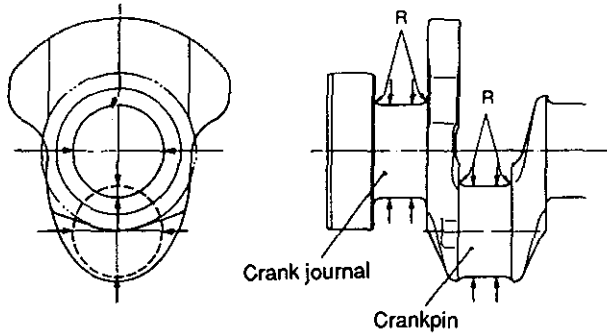
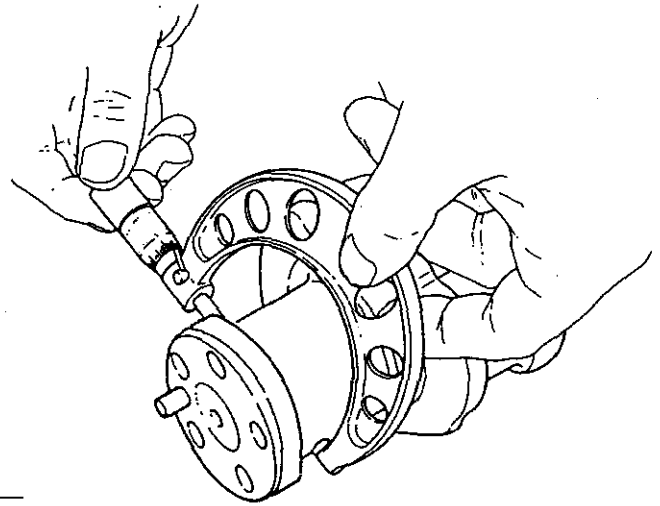

( Measuring position of the crankpin )  
( and crankjournal )

(mm)

		2/3TNE68		3TNE74		3TNE78A 4TNE82A		3/4TNE82, 3/4TNE84(T), 3/4TNE88	
		Standard	Wear limit	Standard	Wear limit	Standard	Wear limit	Standard	Wear limit
Crankpin	Crankpin outside diameter	35.970 ~35.980	35.91	39.970 ~39.980	39.91	42.952 ~42.962	42.91	47.952 ~47.962	47.91
Crank journal	Crankshaft journal outside diameter	39.970 ~39.980	39.90	43.970 ~43.980	43.90	46.952 ~46.962	46.91	53.952 ~53.962	53.91
	Bearing metal thickness	1.487 ~1.500	—	1.987 ~2.000	—	1.987 ~2.000	—	1.995 ~2.010	—
	Crank journal and bushing oil clearance	0.033 ~0.059	0.15	0.033 ~0.059	0.15	0.038 ~0.093	0.25	0.038 ~0.068	0.15

**6. Precautions in mounting the metal cap**

- (1) The lower metal (cap side) has no oil groove.
- (2) The upper metal (cylinder block side) has an oil groove.
- (3) Check the cylinder block alignment No.
- (4) Place the relief mark "FW" of the cap on the flywheel side.
- (5) Place the main bearing metal on the flywheel side.

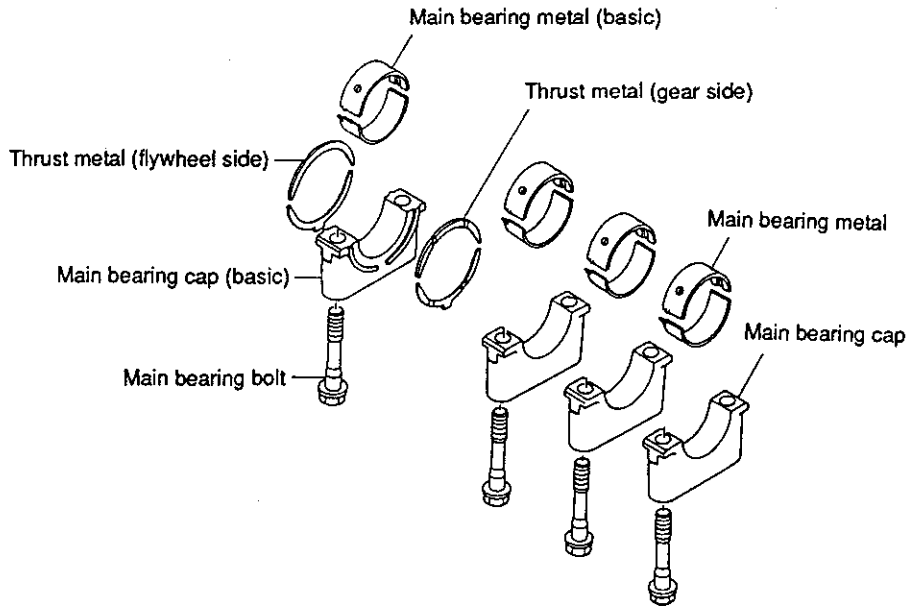

**7. Undersized main metal by 0.25 mm and the oversized thrust metal by 0.25 mm**

	Main metal		Thrust metal	
	Part code	Metal thickness (mm)	Part code	Metal thickness (mm)
		Standard		Standard
2/3TNE68	719260—02870	1.625	119260—02940	2.125
3TNE74	719620—02870	2.125	119620—02940	2.125
3TNE78A/82A	119810—02870	2.125	119810—02940	2.125
3/4TNE82 3/4TNE84(T) 3/4TNE88	129150—02870	2.125	129150—02940	2.125

## 7-8. Gears

### 1. Checking gears

Inspect the gears and replace if the teeth are damaged, worn, or chipped.

### 2. Measuring the backlash

Apply a dial gauge onto the pitch circle of the gear, and measure the backlash.

(mm)

		2/3TNE68, 3TNE74	3TNE78A/82A, 3/4TNE82, 3/4TNE84(T), 3/4TNE88
Back-lash	Crankshaft gear, Camshaft gear, Idle gear and Fuel injection pump drive gear	0.04~0.12	0.07~0.15
	L.O. pump gear	0.11~0.19	

### (Indirect Injection system)

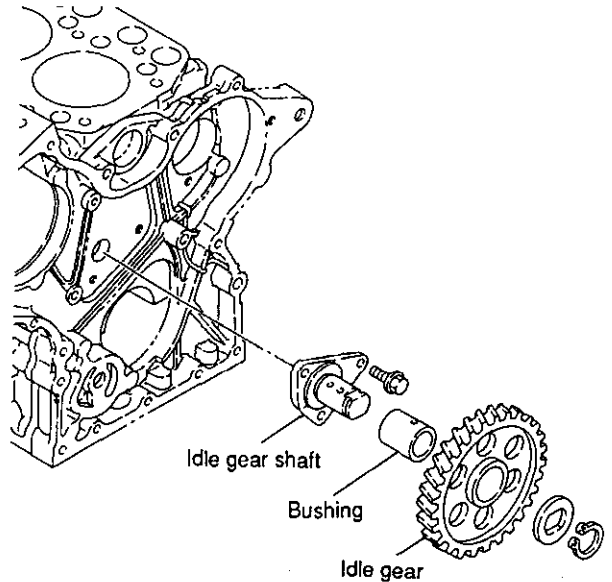

### 3. Checking and measuring the idling gear shaft and idling gear

- Measure the bushing inside diameter and the idle gear shaft outside diameter, and replace the bushing or idling gear shaft if the oil clearance exceeds the wear limit.

(mm)

		2/3TNE68, 3TNE74		3TNE78A/82A, 3/4TNE82, 3/4TNE84(T), 3/4TNE88	
		Standard	Wear limit	Standard	Wear limit
Idle gear	Shaft outside dia.	19.959 ~19.980	19.93	45.950 ~45.975	45.93
	Bushing inside dia.	20.000 ~20.021	—	46.000 ~46.025	46.08
	Oil clearance	0.020 ~0.062	0.15	0.025 ~0.075	0.15

### (Direct Injection system)

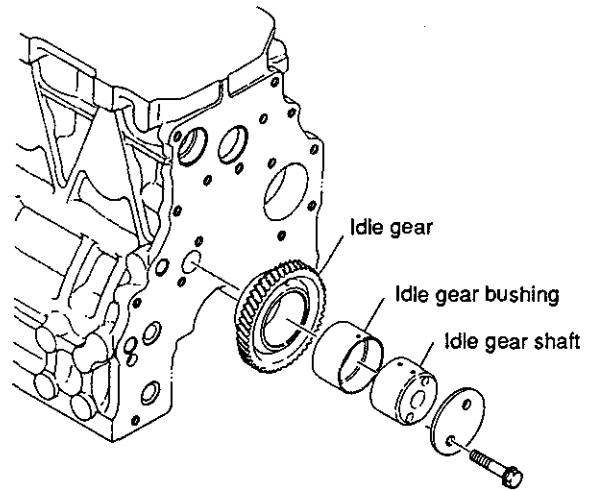

- Make sure that the oil hole of the idle gear shaft and bushing is a through hole.



#### 4. Gear train

After installing each gear, make sure that aligning marks **A**, **B** and **C** of the idle gear are aligned with those of the fuel injection pump gear, cam gear and crank gear.

(View the gear case)

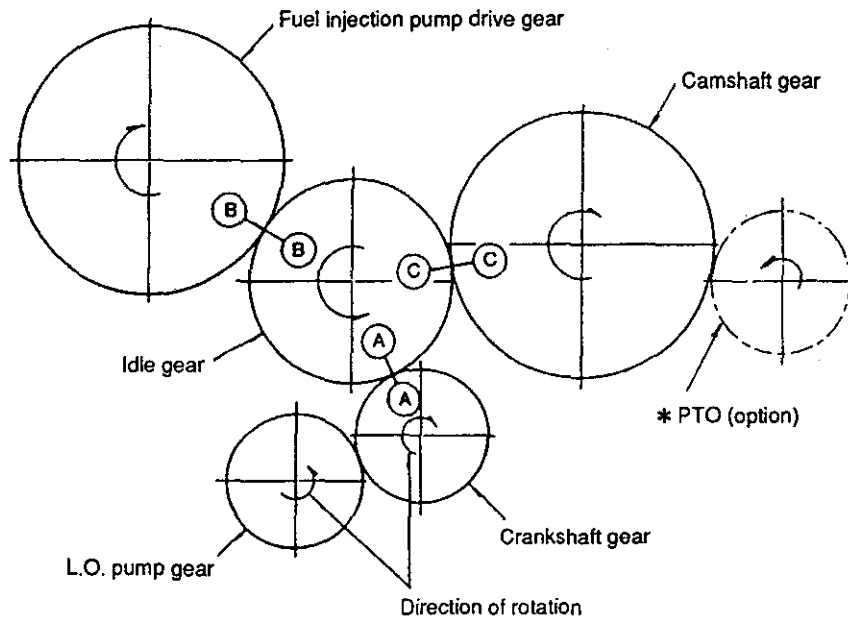

## 7-9. Trochoid pump

### 1. Clearance between outer rotor and pump body

Insert a thickness gauge between the outer rotor and pump body to measure the clearance. (mm)

	All models	
	Standard	Wear limit
Clearance between outer rotor and pump body	0.10~0.16	0.25

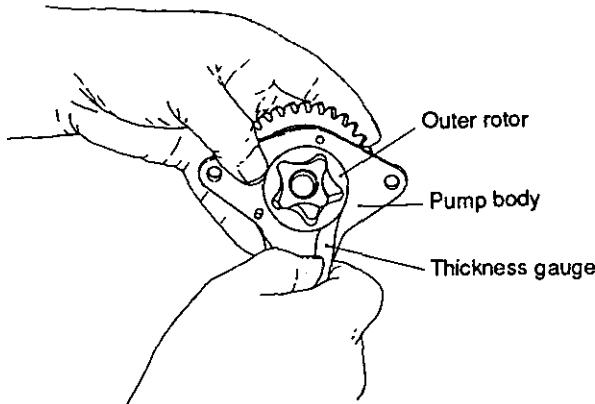

(Measuring the clearance between outer rotor and pump body)

### 2. Clearance between outer rotor and inner rotor

Insert a thickness gauge between the top of the inner rotor tooth and the top of the outer rotor tooth to measure the clearance. (mm)

	All models	
	Standard	Wear limit
Clearance between outer rotor and inner rotor	—	0.15

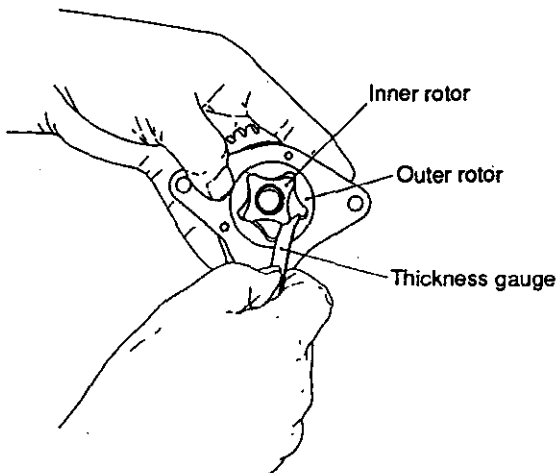

(Measuring the clearance between outer rotor and inner rotor)

### 3. Side clearance between pump body and inner rotor, outer rotor

Place a straight-edge against the end of the pump and insert a thickness gauge between the straight-edge and the rotors to measure the side clearance. (mm)

	2/3TNE68 3TNE74		3TNE78A 3TNE82A		3/4TNE82, 3/4TNE84(T), 3/4TNE88	
	Standard	Wear limit	Standard	Wear limit	Standard	Wear limit
	Pump body and inner-, outer-rotor side clearance	0.03 ~0.09	0.13	0.05 ~0.10	0.15	0.03 ~0.09

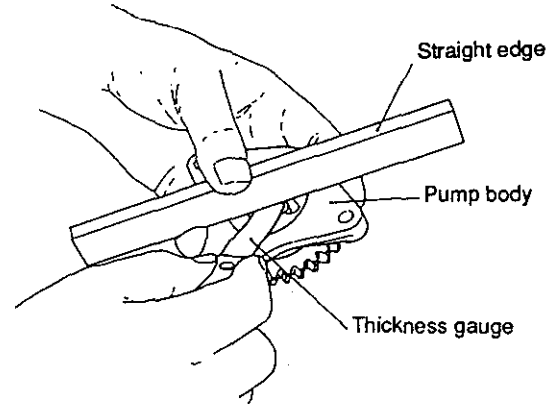

(Measuring the clearance between the pump body and inner-, outer-rotor)

### 4. Clearance between rotor shaft and side cover hole

Measure the rotor shaft outside diameter and the side cover hole diameter, and calculate the difference between the hole diameter and the outside diameter. (mm)

	All models	
	Standard	Wear limit
Clearance between rotor shaft and side cover hole	0.013 ~0.043	0.2

### 5. Others

- (1) Check for looseness of drive gear/rotor shaft fitting, and replace the entire assembly if loose or wobbly.
- (2) Push the oil pressure regulating valve piston from the oil hole side, and replace the entire assembly if the piston does not return due to spring breakage, etc. (Engine with oil cooler only)
- (3) Make sure that the rotor shaft rotates smoothly and easily when the drive gear is rotated.

## 8. Disassembly and Reassembly

Peripheral parts such as air cleaner, muffler and radiator differ in installation and types for each application. Therefore, description in this Chapter is started with the steps to be taken just after the peripheral parts have been removed.

Perform the procedure, with reference to the attached drawings, "Engine component Exploded View."

### 8-1. Disassembly

\* For the number following the part name, refer to attached drawing 1 and 2, "Exploded Views of Engine Components"

Step	Removal Parts	Remarks
1	<ol style="list-style-type: none"> <li>1. Thoroughly remove sand, dust, dirt and soil from the surface of the engine.</li> <li>2. Drain cooling water and lubricating oil from the engine.</li> </ol>	
2	<ol style="list-style-type: none"> <li>1. Remove turbocharger ⑦④ and exhaust manifold ①.</li> <li>2. Remove intake manifold ② and surge tank ⑦⑤.</li> </ol>	
3	<ol style="list-style-type: none"> <li>1. Close the fuel cock valve of the fuel tank.</li> <li>2. Remove high-pressure fuel pipe ③.</li> <li>3. Remove fuel return pipe ④.</li> <li>4. Loosen the tightening nut on fuel injection nozzle retainer ⑤ and extract the retainer and fuel injection nozzle ⑥.</li> </ol> <p>* Fuel injection nozzle for Indirect injection system is screwed type.</p>	<ol style="list-style-type: none"> <li>1. If nozzle seat ⑦ is left on the cylinder head, remove the cylinder head before extracting nozzle seat ⑦.</li> <li>2. To prevent dust from entering fuel injection nozzle ⑥, fuel injection pump ⑧ and high-pressure fuel pipe ③, seal their respective threads with a tape or the like.</li> <li>3. Whenever extracting fuel injection nozzle ⑥, replace nozzle protector ⑨ with a new one.</li> </ol>
4	<ol style="list-style-type: none"> <li>1. Remove bonnet assembly ⑩.</li> </ol>	
5	<ol style="list-style-type: none"> <li>1. Remove valve rocker arm shaft assembly ⑪.</li> <li>2. Remove push rod ⑫.</li> </ol>	<ol style="list-style-type: none"> <li>1. Attach a tag to push rod ⑫ for each cylinder No. to put the push rod in order.</li> <li>2. Remove valve cap ⑬ from the intake/exhaust valve head.</li> <li>3. Note that tappet ⑤⑨ of the indirect injection system can be removed at the same time when push rod ⑫ is extracted.</li> <li>4. Attach a tag to tappet ⑤⑨ for each cylinder No. to put the tappet in order.</li> </ol>

**8. Disassembly and Reassembly**

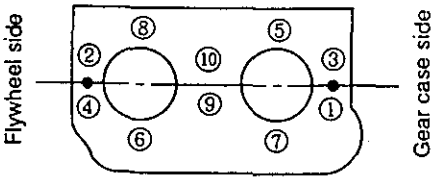
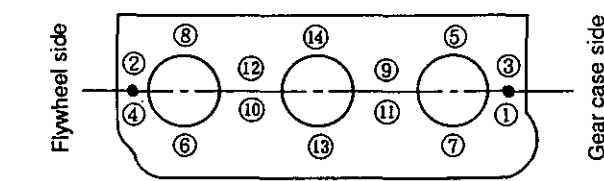
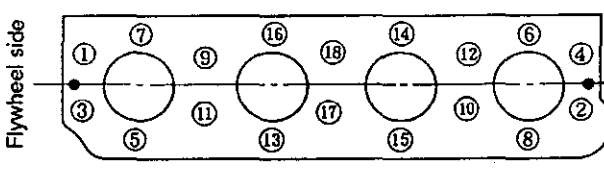
Step	Removal Parts	Remarks
6	<ol style="list-style-type: none"> <li>1. Remove fan mounting bolt ⑭ , and then remove fan ⑮ .</li> <li>2. Loosen adjusting bolt ⑯ for the V-belt adjuster, and then remove V-belt ⑰ .</li> <li>3. Remove alternator ⑱ .</li> <li>4. Remove the spacer for cooling fan ⑲ and V-pulley ⑳ .</li> </ol>	<ol style="list-style-type: none"> <li>1. Never turn down alternator ⑱ vigorously toward the cylinder block. Otherwise, your finger may be nipped and alternator ⑱ broken.</li> </ol>
7	<ol style="list-style-type: none"> <li>1. Remove lubricating oil filter assembly ㉑ .</li> <li>2. Extract dipstick ㉒ from the oil dipstick hole.</li> </ol>	
8	<ol style="list-style-type: none"> <li>1. Disconnect fuel return pipes ㉓ to ㉖ .</li> <li>2. Remove fuel filter ㉗ .</li> </ol>	
9	<ol style="list-style-type: none"> <li>1. Disconnect cooling water pipe ㉘ from the cooling water pump.</li> <li>2. Remove thermostat assembly ㉙ .</li> <li>3. Remove cooling water pump ㉚ .</li> </ol>	
10	<ol style="list-style-type: none"> <li>1. Remove cylinder head tightening bolt ㉛ .</li> <li>2. Remove cylinder head assembly ㉜ .</li> <li>3. Remove cylinder head gasket ㉝ .</li> </ol> <div style="text-align: center;"> <p>Camshaft side</p>  <p>Flywheel side</p> <p>Gear case side</p> <p>Fuel injection pump side</p> </div>	<ol style="list-style-type: none"> <li>1. Lay a cardboard or the like on the floor and place cylinder head assembly ㉜ on it so as not to damage the combustion surface.</li> <li>2. Order of loosening the cylinder head tightening bolts</li> </ol> <div style="text-align: center;"> <p>Camshaft side</p>  <p>Flywheel side</p> <p>Gear case side</p> <p>Fuel injection pump side</p> </div> <div style="text-align: center;"> <p>Camshaft side</p>  <p>Flywheel side</p> <p>Gear case side</p> <p>Fuel injection pump side</p> </div>

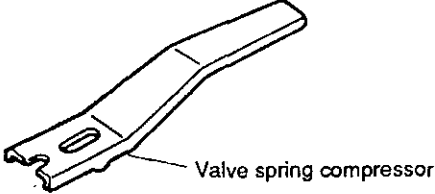
Step	Removal Parts	Remarks
		<p>3. To remove the intake/exhaust valves from cylinder head assembly ③② , take the following steps.</p> <p>(1) Using a valve spring compressor (see Chapter 5, 5-1), compress valve spring ③④ and remove valve cotter ③⑤ .</p>  <p>(2) Remove valve retainer ③⑥ and valve spring ③④ .</p> <p>(3) Remove intake valve ③⑦ and exhaust valve ③⑧ .</p>
11	<ol style="list-style-type: none"> <li>1. Remove crankshaft V-pulley clamping bolt ③⑨ .</li> <li>2. Using a puller, extract crankshaft V-pulley ④⑩ .</li> </ol>	<ol style="list-style-type: none"> <li>1. Extract crankshaft V-pulley ④⑩ by hitting the bolt of the puller using a plastic hammer or the like.</li> </ol>
12	<ol style="list-style-type: none"> <li>1. Remove oil pan mounting bolt ④② under gear case ④① .</li> <li>2. Remove gear case mounting bolt ④③ .</li> <li>3. Remove gear case ④① .</li> </ol>	<ol style="list-style-type: none"> <li>1. Never fail to remove stiffener bolt ④④ at the center of the gear case.</li> <li>2. When removing the gear case, carefully protect oil seal ④⑤ from damage.</li> </ol>
13	<ol style="list-style-type: none"> <li>1. Remove the nut from fuel injection pump drive gear ④⑥ . Extract fuel injection pump drive gear ④⑥ using a puller.</li> </ol>	<ol style="list-style-type: none"> <li>1. Before removing fuel injection pump ⑧ , make sure of the position of the arrow of the pump body for adjusting fuel injection timing as well as the position of the scribed line of the gear case flange. (Applies only to direct injection system.)</li> </ol>
14	<ol style="list-style-type: none"> <li>1. Remove lubricating oil pump ④⑦ .</li> </ol>	
15	<ol style="list-style-type: none"> <li>1. Remove starting motor ⑤⑤ from flywheel housing ⑤④ .</li> </ol>	
16	<ol style="list-style-type: none"> <li>1. Remove flywheel mounting bolt ⑤⑥ .</li> <li>2. Remove flywheel ⑤⑦ .</li> </ol>	<ol style="list-style-type: none"> <li>1. Carefully protect the ring gear from damage.</li> </ol>
17	<ol style="list-style-type: none"> <li>1. Remove flywheel housing ⑤④ .</li> <li>2. Remove oil seal case ⑤⑧ with a screwdriver or the like by utilizing grooves on both sides of oil seal case ⑤⑧ .</li> </ol>	<ol style="list-style-type: none"> <li>1. Carefully protect the oil seal from damage.</li> </ol>

## 8. Disassembly and Reassembly

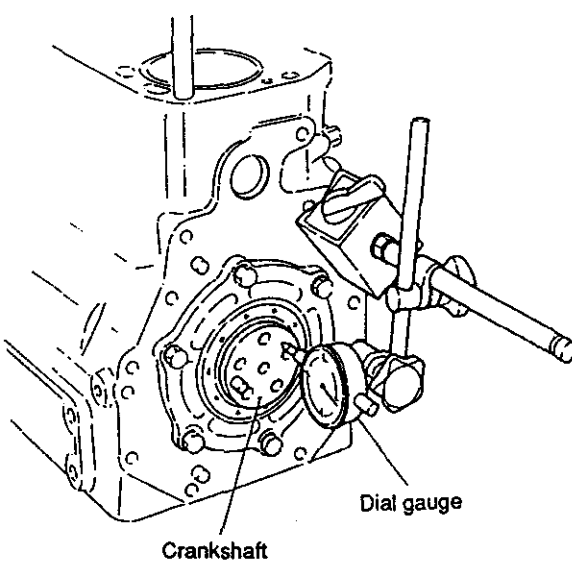
Step	Removal Parts	Remarks
18	1. Remove oil pan ⑥① and spacer ⑥② .	<ol style="list-style-type: none"> <li>1. Put the cylinder block with the attaching surface of the cylinder head facing down.</li> <li>2. Carefully protect the combustion surface of the cylinder block from damage.</li> <li>3. For indirect injection system, be careful to the possibility of the tappet to drop off when the cylinder block is turned upside down, because the tappet is cylindrical in shape.</li> </ol>
19	<ol style="list-style-type: none"> <li>1. Remove idle gear shaft ④⑧ , and then remove idle gear ④⑨ .</li> <li>2. Remove mounting bolt ⑤② of thrust bearing ⑤① through the hole of the camshaft gear ⑤⑩ . Remove camshaft assembly ⑤③ .</li> </ol>	<ol style="list-style-type: none"> <li>1. Turn the cylinder block aside and carefully prevent tappet ⑤⑨ from jamming on the cam.</li> <li>2. Preheat camshaft gear ⑤⑩ and camshaft assembly ⑤③ to 180°C ~ 200°C which are shrink fitted, before removing them.</li> </ol>
20	1. Remove gear case flange ⑥② .	
21	1. Remove lubricating oil strainer ⑥③ .	
22	<ol style="list-style-type: none"> <li>1. Remove crankpin side cap ⑥④ of the connecting rod. <ul style="list-style-type: none"> <li>○ While turning crankshaft ⑥⑤ , place piston ⑥⑥ in the bottom dead center (BDC).</li> </ul> </li> </ol>	<ol style="list-style-type: none"> <li>1. Before extracting piston ⑥⑥ , remove carbon deposits from the upper wall of the cylinder using fine sandpaper, while taking care not to damage the inner surface of the cylinder.</li> <li>2. Make sure that cap No. of connecting rod ⑥⑦ agrees with cylinder No.</li> <li>3. Take care not to let crankpin metal ⑥⑧ fall when removing connecting rod crankpin side cap ⑥④ .</li> </ol>
23	<ol style="list-style-type: none"> <li>1. Remove main bearing cap bolt ⑥⑨ . While shaking main bearing cap ⑦⑩ , remove main bearing cap ⑦⑩ together with lower main bearing metal ⑦① .</li> <li>2. Extract crankshaft ⑥⑤ , taking care not to damage it.</li> <li>3. Remove upper main bearing metal ⑦② .</li> </ol>	<ol style="list-style-type: none"> <li>1. Before extracting crankshaft ⑥⑤ , measure the side gap around it.</li> </ol> 

Step	Removal Parts	Remarks				
		<p>Apply a dial gauge to the end of crankshaft (65) . Force the crankshaft on both sides in the axial direction to measure the thrust gap. Alternatively, insert a thickness gauge directly between the base thrust metal and the thrust surface of the crankshaft to measure the gap. If the limit size is exceeded, replace the thrust metal with a new one.</p> <p style="text-align: right;">(mm)</p> <table border="1" data-bbox="791 524 1471 631"> <tr> <td data-bbox="791 524 1129 568"></td> <td data-bbox="1129 524 1471 568">All models</td> </tr> <tr> <td data-bbox="791 568 1129 631">Thrust gap</td> <td data-bbox="1129 568 1471 631">0.090 ~ 0.271</td> </tr> </table> <p>2. Notice on the removal of thrust metal (73) .</p> <p>(1) When removing thrust metal (73) , ascertain the position and direction where thrust metal is installed in relation to the cap.</p> <p>(2) Make sure that the thrust metal groove is outward in relation to the cap.</p>		All models	Thrust gap	0.090 ~ 0.271
	All models					
Thrust gap	0.090 ~ 0.271					
24	1. Remove piston (66) and connecting rod (67) assembly.	<p>1. To selectively remove a desired piston and connecting rod assembly without extracting crankshaft (65) , take the steps itemized below:</p> <p>(1) Remove carbon deposits from the upper wall of the cylinder using fine sandpaper, taking care not to damage the inner surface of the cylinder.</p> <p>(2) While turning the crankshaft, with the crankpin side cap (64) removed, raise the piston up to the top dead center (TDC).</p> <p>(3) Extract the piston/connecting rod assembly while tapping the connecting rod (67) at the large end with the handle of a plastic hammer or the like.</p>				
25	1. Remove tappet (59) .					

## 8-2. Precautions before and during reassembly

To reassemble engine components, reverse the procedure of disassembly. However, follow the precautions below particularly before and during reassembly.

### (1) Cleaning the component

Use particular care to clean the cylinder block, cylinder head, crankshaft, and camshaft. Ensure that they are free from chips, dust, sand, and other foreign matter.

### (2) Parts to be replaced during reassembly

Be sure to replace the following parts with new ones during assembly.

- (1) Valve stem seal
- (2) Head gasket packing
- (3) Nozzle protector of the fuel injection valve
- (4) Various copper packings, O-rings and gasket packings.

### (3) Measuring the side gap around crankshaft

Apply a dial gauge to the end of the crankshaft. Force the crankshaft on both sides in the axial direction to measure the thrust gap. Alternatively, insert a thickness gauge

directly between the base thrust metal and the thrust surface of the crankshaft to measure the gap. If the limit size is exceeded, replace the thrust metal with a new one.

(mm)	
	All models
Thrust gap	0.090 ~ 0.271

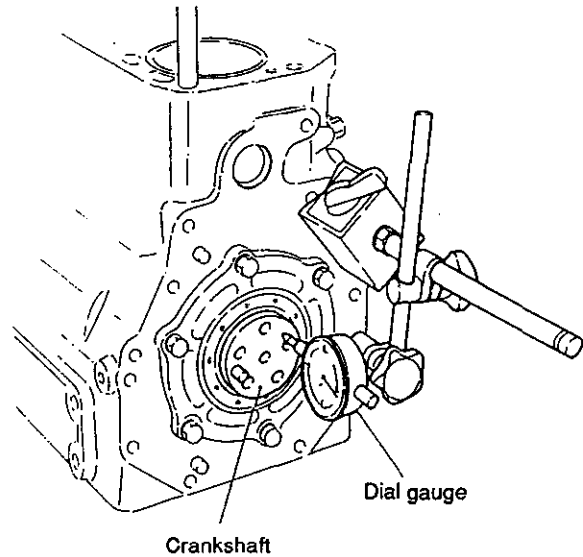

( Measurement of side gap around )  
crankshaft

### (4) Gear train

After having installed each gear, make sure that marks **A**, **B** and **C** of the idle gear align with marks of the fuel injection pump drive gear, camshaft gear and crankshaft gear as shown below.

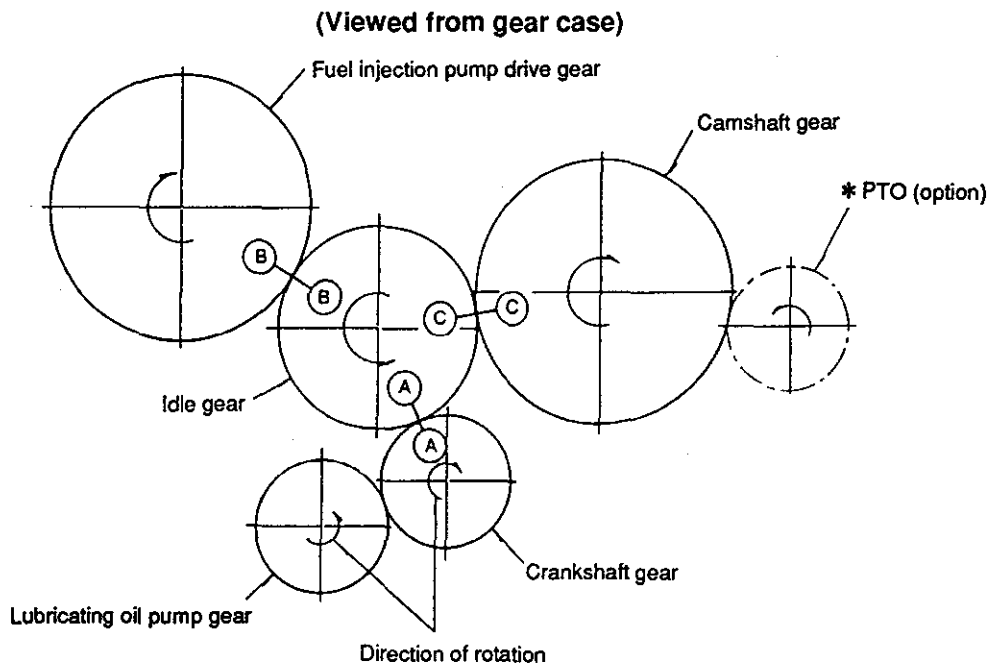



**(5) Where to use liquid packings**

1. Between the cylinder block and gear case flange
2. Between the gear case flange and gear case cover
3. Between the cylinder block and oil seal case (indirect injection system only)
4. Oil pan installation surface

\* Use *Three Bond No. 005* (Yanmar part code: 97777-001212) as the liquid packing.

\* Apply the liquid packing so as not to form any break on the midway. Otherwise, oil leakage, etc., may result.

**(6) Coating the lubricating oil on intake/exhaust valve stem**

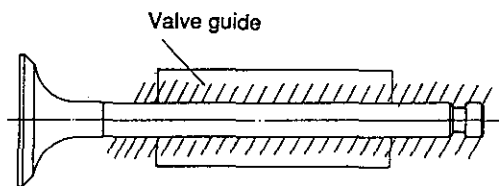

Apply lubricating oil down to the lower surface (hatched portion in the figure) of the valve guide before reassembling the valve stem.

**(7) Reassembly of the piston ring**

1. Insert the piston ring into the ring groove, where the side with the manufacturer's mark on the matching ends facing up (to the combustion chamber side), using a piston ring replacer. After fitting the piston ring, make sure it moves easily and smoothly.

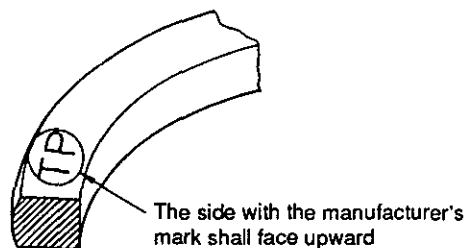

2. Assemble the piston rings to the cylinder, staggering the piston rings joints at 120° intervals, making sure that they are not aligned along the piston. Apply lube oil to the circumference of the piston.

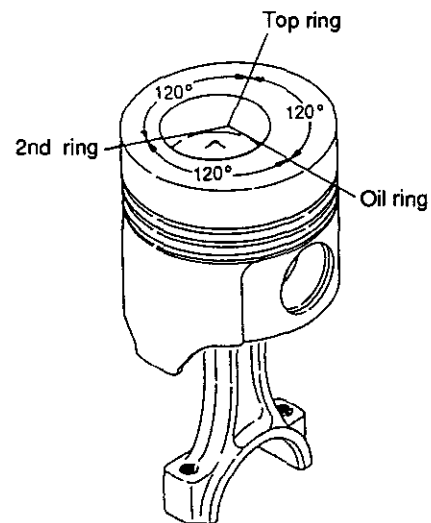
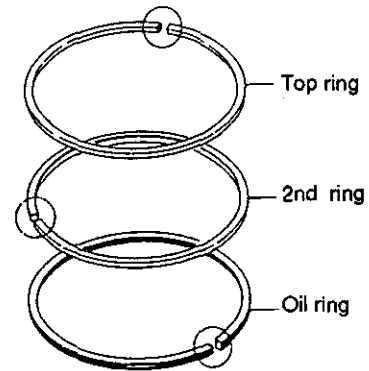

**(8) Coating the lubricating oil to pushrod adjusting screw contact**

Apply lubricating oil to the hatched portion of the push rod as shown in the figure, before reassembly.

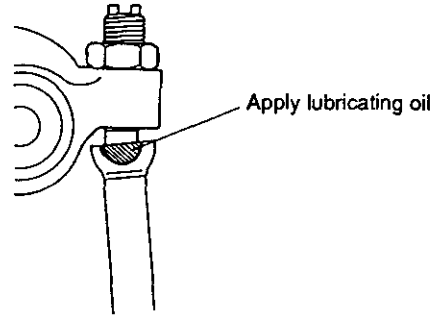

**(9) Assembly direction of piston and connecting rod**

	2/3TNE68, 3TNE74	3TNE78A, 3TNE82A, 3/4TNE82 3/4TNE84(T), 3/4TNE88
Piston	<p>Diagram of a piston for models 2/3TNE68 and 3TNE74. It shows the camshaft side on the left and the nozzle side on the right. The flywheel side is at the bottom and the cylinder size mark is on the left. An I.D. mark is indicated on the piston crown.</p>	<p>Diagram of a piston for models 3TNE78A, 3TNE82A, 3/4TNE82, 3/4TNE84(T), and 3/4TNE88. It shows the camshaft side on the left and the nozzle side on the right. The flywheel side is at the bottom and the cylinder size mark is on the left. An I.D. mark is indicated on the piston crown.</p>
Connecting rod	<p>Diagram of a connecting rod for models 2/3TNE68 and 3TNE74. It shows an embossed mark on the flywheel side and an alignment mark on the opposite side.</p>	<p>Diagram of a connecting rod for models 3TNE78A, 3TNE82A, 3/4TNE82, 3/4TNE84(T), and 3/4TNE88. It shows an embossed mark on the flywheel side and an alignment mark on the opposite side.</p>

**(10) Order of tightening cylinder heads and tightening torque**

Tighten cylinder heads in numerical order shown below to the specified torque.

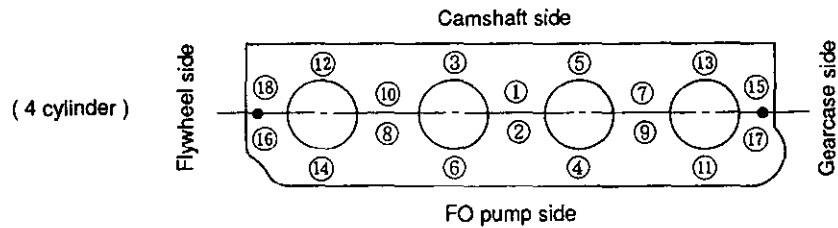
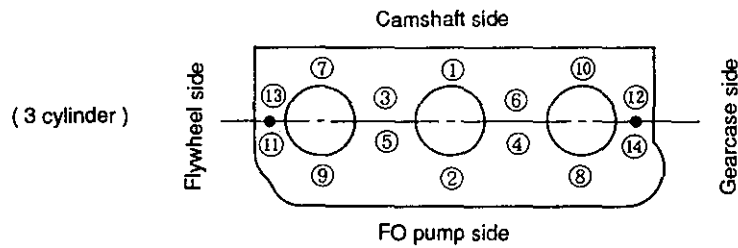
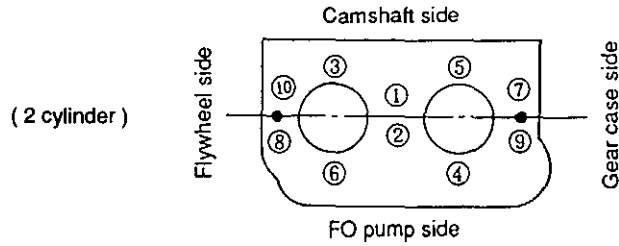

(kgf-m)

	2/3TNE68	3TNE74	3TNE78A 3TNE82A	3/4TNE82 3/4TNE84(T) 3/4TNE88
Tightening torque	3.8 ~4.2	6.0~6.5	6.8~7.2	8.7~9.3

**(11) After having reassembled the cylinder heads, carry out confirmation running to see if they are free from leakage of water and oil.**

# 9. Service Data

## 9-1 Cylinder Head

(Unit: mm)

Item		Model		2/3TNE68		3TNE74		3TNE78A 3TNE82A		3/4TNE82, 3/4TNE84(T), 3/4TNE88	
		Standard	Wear limit	Standard	Wear limit	Standard	Wear limit	Standard	Wear limit		
Cylinder head combustion surface distortion		0.05 or less	0.15	0.05 or less	0.15	0.05 or less	0.15	0.05 or less	0.15	0.05 or less	0.15
Valve seat angle	Intake	120°	—	120°	—	120°	—	120°	—	120°	—
	Exhaust	90°	—	90°	—	90°	—	90°	—	90°	—
Valve seat width	Intake	1.15	1.65	1.44	1.98	1.36~1.53	1.98	1.07~1.24	1.74		
	Exhaust	1.41	1.91	1.77	2.27	1.66~1.87	2.27	1.24~1.45	1.94		
Intake valve	Valve stem outside dia.	5.460 ~5.475	5.4	6.960 ~6.975	6.9	6.945 ~6.960	6.9	7.955 ~8.025	7.9		
	Valve guide inside dia.	5.500 ~5.515	5.58	7.005 ~7.020	7.08	7.000 ~7.015	7.08	8.010 ~7.975	8.1		
	Oil clearance	0.025 ~0.055	0.18	0.030 ~0.060	0.18	0.040 ~0.070	0.18	0.035 ~0.070	0.2		
Exhaust valve	Valve stem outside dia.	5.445 ~5.460	5.4	6.945 ~6.960	6.9	6.940 ~6.955	6.9	7.955 ~8.030	7.9		
	Valve guide inside dia.	5.500 ~5.515	5.58	7.005 ~7.020	7.08	7.000 ~7.015	7.08	8.015 ~7.970	8.1		
	Oil clearance	0.040 ~0.070	0.18	0.045 ~0.075	0.18	0.045 ~0.075	0.18	0.045 ~0.075	0.2		
Valve guide projection		7	—	9	—	12	—	15	—		
Valve sinking depth	Intake valve	0.3~0.5	1.0	0.4~0.6	1.0	0.296 ~0.496	1.0	0.306 ~0.506	1.0		
	Exhaust valve	0.75~0.95		VM: 0.75~0.95 CH: 0.40~0.60 VH: 0.40~0.60		0.3~0.5		0.3~0.5			
Thickness of valve head	Intake valve	0.85~1.15	0.5	0.99~1.29	0.5	1.244 ~1.444	0.5	1.244 ~1.444	0.5		
	Exhaust valve	0.95~1.25		0.95~1.25		1.35~1.55		1.35~1.55			
Intake valve timing	Open	b.TDC	—	7°~17°	—	10°~20°	—	10°~20°	—		
	Close	a.BDC		37°~47°		35°~45°		40°~50°		40°~50°	
Exhaust valve timing	Open	b.BDC	—	40°~50°	—	51°~60°	—	51°~61°	—		
	Close	a.TDC		5°~15°		8°~18°		13°~23°		13°~23°	
Valve spring	Free length		28	—	37.4	—	44.4	—	42	—	
	Inclination		—	0.8	—	1.0	—	1.1	—	1.1	
	Tension (kg) (when compressed to 1mm length)		1.14 ~1.40	—	2.37 (variable pitch) /1.87	—	3.61 (variable pitch) /2.71	—	2.36 (variable pitch) /3.101	—	
Intake & exhaust valve clearance		0.15~0.25	—	0.15~0.25	—	0.15~0.25	—	0.15~0.25	—		

## 9-2 Cylinder Block

(Unit: mm)

Model		2/3TNE68		3TNE74		3TNE78A	
		Standard	Wear limit	Standard	Wear limit	Standard	Wear limit
Cylinder bore		68.000 ~68.030	68.20	74.000 ~74.030	74.20	78.000 ~78.030	78.20
Cylinder bore	L mark	68.020 ~68.030		74.020 ~74.030		78.020 ~78.030	
	M mark	68.010 ~68.020		74.010 ~74.020		78.010 ~78.020	
	S mark	68.000 ~68.010		74.000 ~74.010		78.000 ~78.010	
Cylinder roundness		0.00 ~0.01	0.03	0.00 ~0.01	0.03	0.00 ~0.01	0.03
Cylindricity		0.00 ~0.01	0.03	0.00 ~0.01	0.03	0.00 ~0.01	0.03

Model		3TNE82A 3/4TNE82		3/4TNE84(T)		3/4TNE88	
		Standard	Wear limit	Standard	Wear limit	Standard	Wear limit
Cylinder bore		82.000 ~82.030	82.20	84.000 ~84.030	84.20	88.000 ~88.030	88.20
Cylinder bore	L mark	82.020 ~82.030		84.020 ~84.030		88.020 ~88.030	
	M mark	82.010 ~82.020		84.010 ~84.020		88.010 ~88.020	
	S mark	82.000 ~82.010		84.000 ~84.010		88.000 ~88.010	
Cylinder roundness		0.00 ~0.01	0.03	0.00 ~0.01	0.03	0.00 ~0.01	0.03
Cylindricity		0.00 ~0.01	0.03	0.00 ~0.01	0.03	0.00 ~0.01	0.03

## 9-3 Valve rocker arm

(Unit: mm)

Model		2/3TNE68		3TNE74		3TNE78A/82A, 3/4TNE82, 3/4TNE84(T), 3/4TNE88	
		Standard	Wear limit	Standard	Wear limit	Standard	Wear limit
Intake & Exhaust rocker arm	Rocker arm shaft outside dia.	9.972~9.987	9.95	11.966~11.984	11.95	15.966~15.984	15.95
	Rocker arm bushing inside dia.	10.000~10.020	10.09	12.000~12.020	12.09	16.000~16.020	16.09
	Oil clearance	0.013~0.048	0.14	0.016~0.054	0.14	0.016~0.054	0.14
Pushrod bending		0.03 or less	—	0.03 or less	—	0.03 or less	—
Tappet	Tappet stem outside dia.	17.950~17.968	17.93	20.927~20.960	20.90	11.975~11.990	11.93
	Tappet guide hole inside dia.	18.000~18.018	18.05	21.000~21.021	21.05	12.000~12.018	12.05
	Oil clearance	0.032~0.068	0.12	0.040~0.094	0.15	0.010~0.043	0.12

## 9-4 Piston

(Unit: mm)

Model		2/3TNE68				3TNE74		3TNE78A		3TNE82A	
		VM, VH		CH		Standard	Wear limit	Standard	Wear limit	Standard	Wear limit
		Standard	Wear limit	Standard	Wear limit						
Piston outside dia.		67.960 ~67.990	67.90	67.940 ~67.970	67.90	73.940 ~73.970	73.90	77.950 ~77.980	77.90	81.950 ~81.980	81.90
Piston outside dia.	L mark	67.980 ~67.990		67.960 ~67.970		73.960 ~73.970		77.970 ~77.980			
	ML mark	67.975 ~67.980		67.955 ~67.960		73.955 ~73.960		77.965 ~77.970			
	MS mark	67.970 ~67.975		67.950 ~67.955		73.950 ~73.955		77.960 ~77.965			
	S mark	67.960 ~67.970		67.940 ~67.950		73.940 ~73.950		77.950 ~77.960			
Min. clearance between piston and cylinder		0.025 ~0.055	—	0.045 ~0.075	—	0.045 ~0.075	—	0.035 ~0.065	—	0.035 ~0.065	—
Top clearance		0.610 ~0.730		—	0.658 ~0.778	—	0.650 ~0.770	—	0.650 ~0.770	—	
Piston and piston pin	Piston pin outside dia.	19.991 ~20.000	19.90	20.991 ~21.000	20.90	22.991 ~23.000	22.90	22.991 ~23.000	22.90		
	Piston pin hole dia.	20.000 ~20.008	20.02	21.000 ~21.008	21.02	23.000 ~23.008	23.02	23.000 ~23.008	23.02		
	Oil clearance	0.000 ~0.017	0.12	0.000 ~0.017	0.12	0.000 ~0.017	0.12	0.000 ~0.017	0.12		

Model		3/4TNE82		3/4TNE84(T)		3/4TNE88	
		Standard	Wear limit	Standard	Wear limit	Standard	Wear limit
Piston outside dia.		81.945 ~81.975	81.90	83.945 ~83.975	83.90	87.945 ~87.975	87.90
Piston outside dia.	L mark	81.965 ~81.975		83.965 ~83.975		87.965 ~87.975	
	ML mark	81.960 ~81.965		83.960 ~83.965		87.960 ~87.965	
	MS mark	81.955 ~81.960		83.955 ~83.960		87.955 ~87.960	
	S mark	81.945 ~81.955		83.945 ~83.955		87.945 ~87.955	
Min. clearance between piston and cylinder		0.040 ~0.070	—	0.040 ~0.070	—	0.040 ~0.070	—
Top clearance		0.660 ~0.780	—	0.660 ~0.780	—	0.660 ~0.780	—
Piston and piston pin	Piston pin outside dia.	25.987 ~26.000	25.90	25.987 ~26.000	25.90	25.987 ~26.000	25.90
	Piston pin hole dia.	26.000 ~26.009	26.02	26.000 ~26.009	26.02	26.000 ~26.009	26.02
	Oil clearance	0.000 ~0.022	0.12	0.000 ~0.022	0.12	0.000 ~0.022	0.12

## 9-5 Piston Ring

(Unit: mm)

Model		2/3TNE68		3TNE74		3TNE78A	
		Standard	Wear limit	Standard	Wear limit	Standard	Wear limit
Top ring	Ring groove width	1.550 ~1.570	—	1.550 ~1.570	—	2.035 ~2.050	—
	Ring width	1.470 ~1.490	—	1.470 ~1.490	—	1.940 ~1.960	—
	Min. side clearance	0.060 ~0.100	—	0.060 ~0.100	—	0.075 ~0.110	—
	End clearance	0.100 ~0.250	1.5	0.200 ~0.400	1.5	0.200 ~0.400	1.5
2nd ring	Ring groove width	1.540 ~1.555	—	1.520 ~1.535	—	2.025 ~2.040	—
	Ring width	1.430 ~1.450	—	1.410 ~1.430	—	1.975 ~1.990	—
	Min. side clearance	0.090 ~0.125	—	0.090 ~0.125	—	0.035 ~0.065	—
	End clearance	0.150 ~0.350	1.5	0.200 ~0.400	1.5	0.250 ~0.400	1.5
Oil ring	Ring groove width	3.010 ~3.025	—	3.010 ~3.025	—	3.015 ~3.030	—
	Ring width	2.970 ~2.990	—	2.970 ~2.990	—	2.970 ~2.990	—
	Min. side clearance	0.020 ~0.055	—	0.020 ~0.055	—	0.025 ~0.060	—
	End clearance	0.150 ~0.350	1.5	0.150 ~0.350	1.5	0.200 ~0.400	1.5

Model		3TNE82A 3/4TNE82		3/4TNE84(T)		3/4TNE88	
		Standard	Wear limit	Standard	Wear limit	Standard	Wear limit
Top ring	Ring groove width	2.065 ~2.080	—	2.065 ~2.080	—	2.060 ~2.075	—
	Ring width	1.970 ~1.990	—	1.970 ~1.990	—	1.970 ~1.990	—
	Min. side clearance	0.075 ~0.110	—	0.075 ~0.1100	—	0.070 ~0.105	—
	End clearance	0.200 ~0.400	1.5	0.200 ~0.400	1.5	0.200 ~0.400	1.5
2nd ring	Ring groove width	2.035 ~2.050	—	2.035 ~2.050	—	2.025 ~2.040	—
	Ring width	1.970 ~1.990	—	1.970 ~1.990	—	1.970 ~1.990	—
	Min. side clearance	0.045 ~0.080	—	0.045 ~0.080	—	0.035 ~0.070	—
	End clearance	0.200 ~0.400	1.5	0.200 ~0.400	1.5	0.200 ~0.400	1.5
Oil ring	Ring groove width	4.015 ~4.030	—	4.015 ~4.030	—	4.015 ~4.030	—
	Ring width	3.970 ~3.990	—	3.970 ~3.990	—	3.970 ~3.990	—
	Min. side clearance	0.025 ~0.060	—	0.025 ~0.060	—	0.025 ~0.060	—
	End clearance	0.200 ~0.400	1.5	0.200 ~0.450	1.5	0.200 ~0.400	1.5

## 9-6 Connecting Rod

(Unit: mm)

Model		2/3TNE68		3TNE74		3TNE78A 3TNE82A		3/4TNE82, 3/4TNE84(T), 3/4TNE88	
		Standard	Wear limit	Standard	Wear limit	Standard	Wear limit	Standard	Wear limit
Crankpin side	Crankpin bushing inside dia.	39.000 ~39.016	—	43.000 ~43.016	—	46.000 ~46.016	—	51.000 ~51.010	—
	Crankpin metal thickness	1.487 ~1.500	—	1.487 ~1.500	—	1.487 ~1.500	—	1.492 ~1.500	—
	Crankpin outside dia.	35.970 ~35.980	35.91	39.970 ~39.980	39.91	42.952 ~42.962	42.91	47.952 ~47.962	47.91
	Oil clearance	0.033 ~0.059	0.15	0.033 ~0.059	0.15	0.038 ~0.090	0.16	0.038 ~0.074	0.16
Piston pin side	Piston pin bushing inside dia.	20.025 ~20.038	20.10	21.025 ~21.038	21.10	23.025 ~23.038	23.10	26.025 ~26.038	26.10
	Piston pin outside dia.	19.991 ~20.000	19.90	20.991 ~21.000	20.90	22.991 ~23.000	22.90	25.987 ~26.000	25.90
	Oil clearance	0.025 ~0.047	0.2	0.025 ~0.047	0.2	0.025 ~0.047	0.2	0.025 ~0.051	0.2
Twist and parallelism		Less than 0.03 per 100 mm	0.08	Less than 0.03 per 100 mm	0.08	Less than 0.03 per 100 mm	0.08	Less than 0.03 per 100 mm	0.08

## 9-7 Camshaft

(Unit: mm)

Model		2/3TNE68		3TNE74		3TNE78A/82A, 3/4TNE82, 3/4TNE84(T), 3/4TNE88	
		Standard	Wear limit	Standard	Wear limit	Standard	Wear limit
Gear side	Camshaft journal outside dia.	35.940 ~35.960	35.85	39.940 ~39.960	39.85	44.925 ~44.950	44.85
	Oil clearance	0.040 ~0.085	—	0.040 ~0.085	—	0.040 ~0.130	—
Intermediate	Camshaft journal outside dia.	35.910 ~35.935	35.85	39.910 ~39.935	39.85	44.910 ~44.935	44.85
	Oil clearance	0.065 ~0.115	—	0.065 ~0.115	—	0.065 ~0.115	—
Flywheel side	Camshaft journal outside dia.	35.940 ~35.960	35.85	39.940 ~39.960	39.85	44.925 ~44.950	44.85
	Oil clearance	0.040 ~0.125	—	0.040 ~0.125	—	0.050 ~0.100	—

## 9-8 Crankshaft

(Unit: mm)

Model		2/3TNE68		3TNE74		3TNE78A 3TNE82A		3/4TNE82, 3/4TNE84(T), 3/4TNE88	
		Standard	Wear limit	Standard	Wear limit	Standard	Wear limit	Standard	Wear limit
Crank journal	Crankshaft journal outside dia.	39.970 ~39.980	39.90	43.970 ~43.980	43.90	46.952 ~46.962	46.91	53.952 ~53.962	53.91
	Bearing metal thickness	1.487 ~1.500	—	1.987 ~2.000	—	1.987 ~2.000	—	1.995 ~2.000	—
	Crank journal and bushing oil clearance	0.033 ~0.059	0.15	0.033 ~0.059	0.15	0.038 ~0.093	0.25	0.038 ~0.068	0.15
Bend		0.02 or less	—	0.02 or less	—	0.02 or less	—	0.02 or less	—



### 9-9 Side Gap and Backlash

(Unit: mm)

Item		Model	All models
			Standard
Side gap	Crankshaft		0.090~0.271
	Camshaft		0.05~0.25
	Connecting rod		0.2~0.4
	Idle gear		0.1~0.3

(Unit: mm)

Item		Model	2/3TNE68, 3TNE74	3TNE78A/82A, 3/4TNE82, 3/4TNE84(T), 3/4TNE88
		Backlash	Crankshaft gear, Camshaft gear, Idle gear and Fuel injection pump drive gear	
L.O. pump gear			0.11 ~ 0.19	

### 9-10 Others

(Unit: mm)

Item			Model	2/3TNE68	3TNE74	3TNE78A 3TNE82A	3/4TNE82, 3/4TNE84(T), 3/4TNE88
Lubricating oil pump discharge volume	High speed operation	$e/min$		11.9 (at 3600rpm) 2.5 (at 750rpm)	15.8 (at 3600rpm)	19.6 (at 3600rpm) 4.4 (at 800rpm)	25.0 (at 3000rpm) 8.0 (at 800rpm)
	Low speed operation						
Pressure control valve opening pressure			$kgf/cm^2$	3.0~4.0	3.0~4.0	3.0~4.0	3.0~4.0
L.O. pressure switch operating pressure			$kgf/cm^2$	0.4~0.6	0.4~0.6	0.4~0.6	0.4~0.6
Cooling water pump discharge volume			$e/min$	45 (at 4320~ 4380 rpm) 32 (at 3320~ 3380 rpm)	55 (at 4320~ 4380 rpm) 40 (at 3320~ 3380 rpm)	35 (at 3220~ 3280 rpm)	70 (at 3220~ 3280 rpm)
Thermostat valve opening temperature	Opening temperature	$^{\circ}C$		69.5~72.5	69.5~72.5	69.5~72.5	69.5~72.5
	Lift height	mm		Min. 4.5 (at 85°C and above)	Min. 8.0 (at 85°C and above)	Min. 8.0 (at 85°C and above)	Min. 8.0 (at 85°C and above)
Thermoswitch operating temperature	ON	$^{\circ}C$		107~113	107~113	107~113	107~113
	OFF			100 and above	100 and above	100 and above	100 and above

# 10. Tightening Torque

## 10-1 Main bolt/nut

(Unit: kgf-m)

No.	Item	Model				
		Torque	2/3TNE68	3TNE74	3TNE78A 3TNE82A	3/4TNE82, 3/4TNE84(T), 3/4TNE88
1	Cylinder head bolt	Lubricating oil applied (Thread dia. × pitch)	3.8~4.2 (M8 × 1.25)	6.0~6.5 (M9 × 1.25)	6.8~7.2 (M9 × 1.25)	8.7~9.3 (M10 × 1.25)
2	Connecting rod bolt	Lubricating oil applied (Thread dia. × pitch)	2.3~2.8 (M7 × 1.0)	2.3~2.8 (M7 × 1.0)	3.8~4.2 (M8 × 1.0)	4.5~5.5 (M9 × 1.0)
3	Flywheel clamping bolt	Lubricating oil applied (Thread dia. × pitch)	8.2~8.8 (M10 × 1.25)	8.0~9.0 (M10 × 1.25)	8.5~9.0 (M10 × 1.25)	8.5~9.0 (M10 × 1.25)
4	Metal cap clamping bolt	Lubricating oil applied (Thread dia. × pitch)	5.3~5.7 (M9 × 1.25)	8.0~8.5 (M10 × 1.25)	7.8~8.2 (M10 × 1.5)	9.8~10.2 (M12 × 1.5)
5	Crankshaft V-pulley clamping bolt	Lubricating oil applied (Thread dia. × pitch)	S48C:11.5~12.5 FC25: 8.5~9.5 (M12 × 1.5)	S48C:11.5~12.5 FC25: 8.5~9.5 (M12 × 1.5)	11.5~12.5 (M14 × 1.5)	11.5~12.5 (M14 × 1.5)
6	Fuel injection nozzle nut	Lubricating oil not applied (Thread dia. × pitch)	5.0~5.4 (M20 × 1.5)	5.0~5.4 (M20 × 1.5)	0.7~0.9 (M6 × 1.0)	0.7~0.9 (M6 × 1.0)
7	Timer clamping nut	Lubricating oil not applied (Thread dia. × pitch)	—	—	6.0~7.0 (M12 × 1.75)	6.0~7.0 (M12 × 1.75)
8	Glow plug	Lubricating oil not applied (Thread dia. × pitch)	1.5~2.0 (M10 × 1.25)	1.5~2.0 (M10 × 1.25)	—	—
9	Stub shaft bolt	Lubricating oil not applied (Thread dia. × pitch)	5.5~6.5 (M10 × 1.5)	5.5~6.5 (M10 × 1.5)	—	—
10	Governor weight support nut	Lubricating oil not applied (Thread dia. × pitch)	7.0~7.5 (M12 × 1.25)	7.0~7.5 (M12 × 1.25)	4.5~5.0 (M12 × 1.25)	4.5~5.0 (M12 × 1.25)
11	High pressure pipe sleeve clamping nut	Lubricating oil not applied (Thread dia. × pitch)	3.0~3.5 (M12 × 1.5)	3.0~3.5 (M12 × 1.5)	3.0~3.5 (M12 × 1.5)	3.0~3.5 (M12 × 1.5)

## 10-2 Standard bolt and nut

\* : Lubricating oil not applied

(Unit: kgf-m)

Item	Thread dia. × pitch	Tightening torque	Remarks
Hexagon headed bolt (7T) and nut	M6 × 1	1.0~1.2	1) When bolting the aluminum parts, tighten the bolts with 80% of the tightening torque specified in the Table. 2) 4T bolt and lock nut should be tightened with 60% of the torque shown in the table.
	M8 × 1.25	2.3~2.9	
	M10 × 1.5	4.5~5.5	
	M12 × 1.75	8.0~10.0	
PT plug	1/8	1.0	_____
	1/4	2.0	
	3/8	3.0	
	1/2	6.0	
Pipe joint bolt	M8	1.3~1.7	_____
	M12	2.5~3.5	
	M14	4.0~5.0	
	M16	5.0~5.5	

# 11. Fuel Injection Pump for Indirect Injection System

## 11-1. Exploded view (YPFR type)

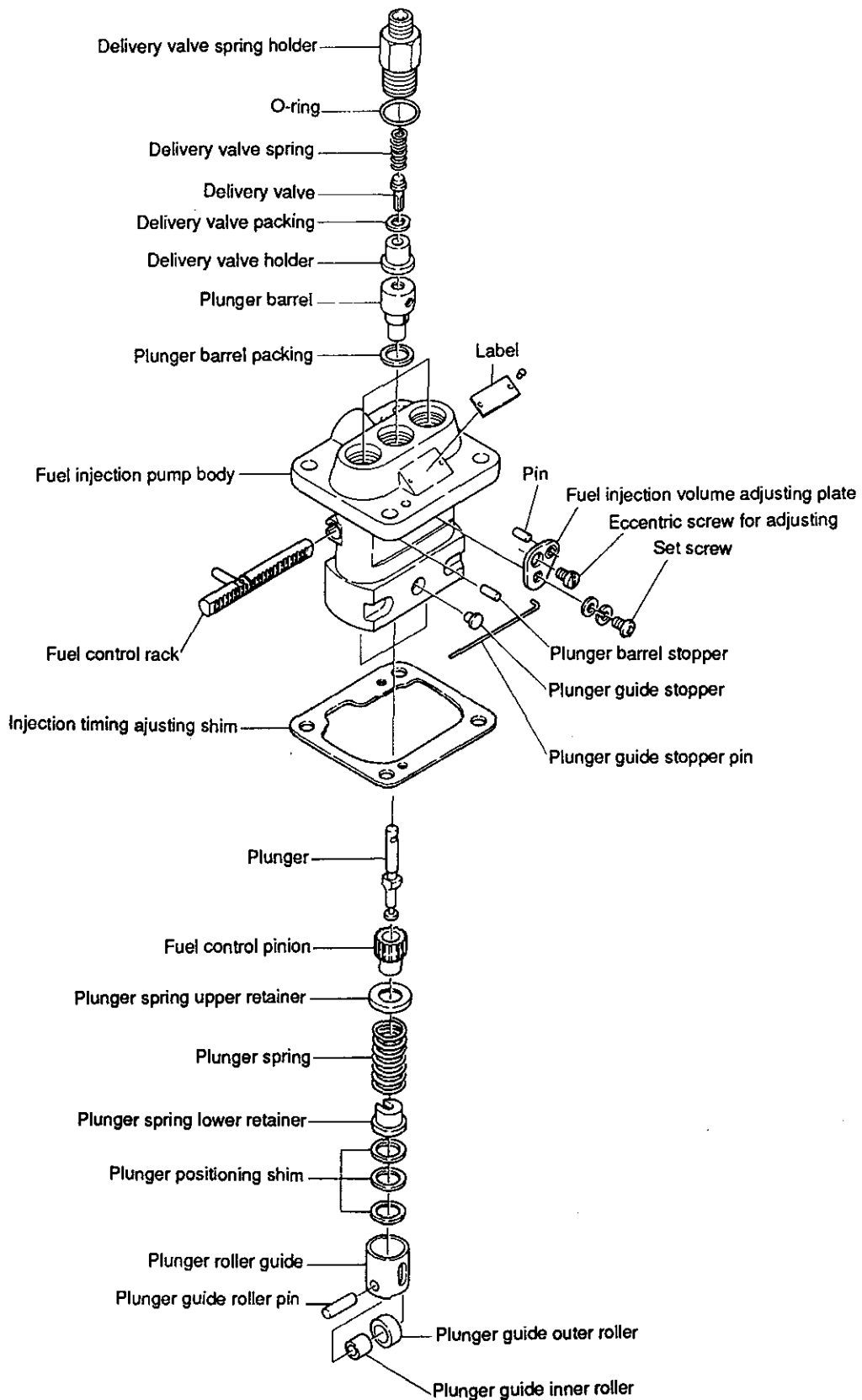

## 11-2. Disassembly

To disassemble the fuel injection pump, classify disassembled parts for each cylinder and carefully avoid allowing them to be mixed with one another. Identifiably classify paired parts supplied as assemblies, such as "plunger and plunger barrel" and "delivery valve and delivery valve holder" for each cylinder. Use particular care to prevent the assembly from going to pieces and being scattered.

- (1) Remove the fuel injection pump.
- (2) Extract the plunger guide stopper pin and remove the plunger guide stopper and plunger barrel stopper.

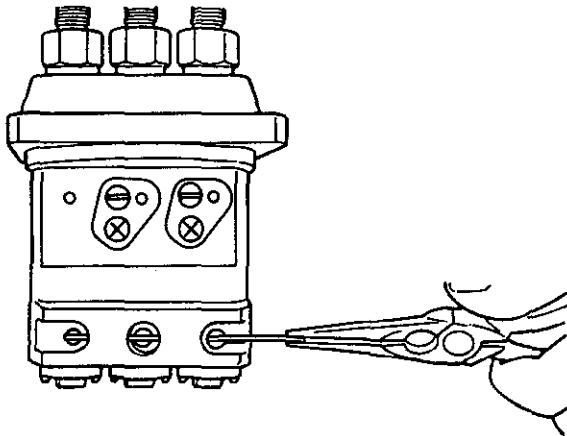

- (3) Remove the right plunger roller guide assembly.

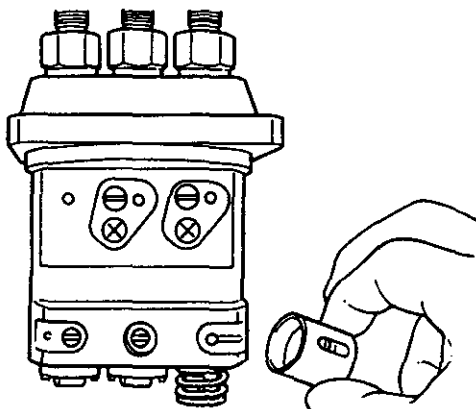

- (4) Remove the plunger spring and plunger spring lower retainer.

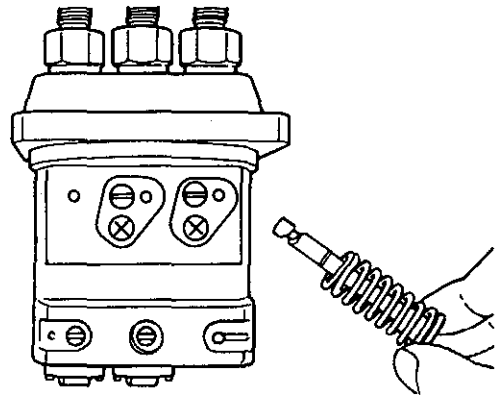

- (5) Remove the plunger spring upper retainer and the fuel control pinion.

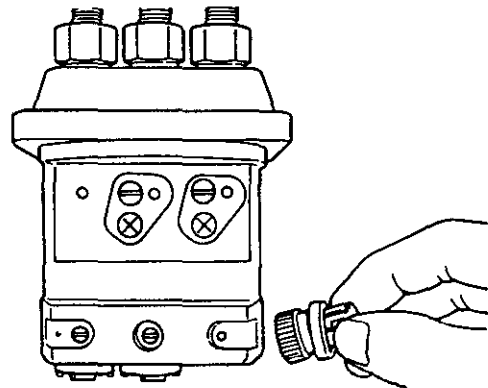

- (6) Remove the delivery valve spring holder and then remove fuel control rack, delivery valve holder, delivery valve spring and delivery valve.

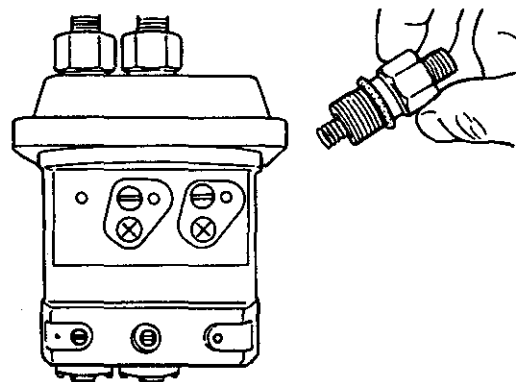

(7) Remove the plunger barrel assembly.

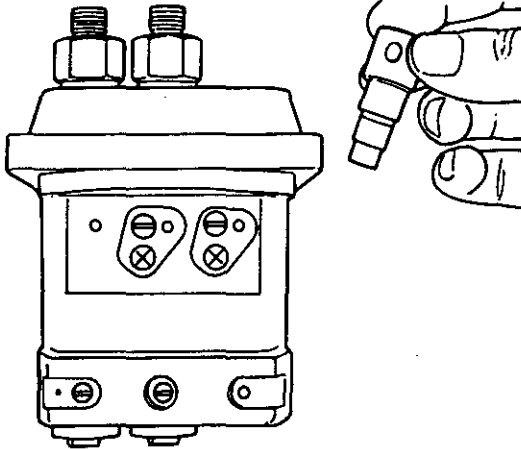

(8) Remove the other plungers by repeating the above steps.

*\* Never loosen the eccentric screw for adjusting and set screw for the fuel injection volume adjusting plate.*

### 11-3. Inspection

Before inspection, thoroughly clean the parts, using new diesel oil. Be careful to avoid damage to the sliding surface of the plunger and delivery valve, etc.

(1) **Plunger guide outer roller, inner roller and plunger roller guide.**

Inspect for wear and scratches with the plunger guide outer roller, inner roller and plunger roller guide. If a gap between the fuel injection pump camshaft and plunger guide outer roller exceeds 0.3 mm, replace the plunger roller guide assembly with a new one.

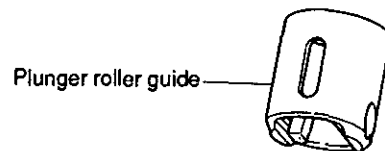

Plunger roller guide



Plunger guide roller pin

Plunger guide inner roller

Plunger guide outer roller

(2) **Fuel control rack and fuel control pinion**

1. Inspect for bending of fuel control rack and wear or deformation of engaged surface of fuel control pinion and fuel control rack.

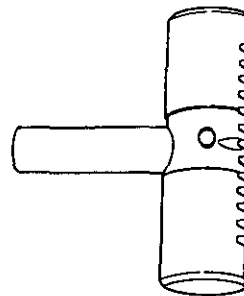

(Fuel control rack)

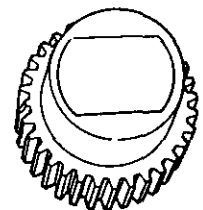

(Fuel control pinion)

2. Check to see if the fuel control rack moves smoothly. If not, replace the fuel control rack with a new one.

**(3) Plunger**

1. Thoroughly clean the plunger. If any plunger lead is scratched or discolored, replace the plunger assembly with a new one.

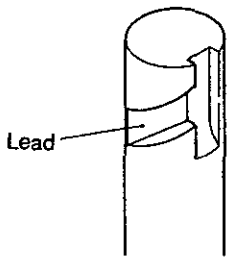

(Plunger)

2. To test the plunger, hold the plunger barrel tilted approx. 60° and check to see if it slides down smoothly. If so, the plunger is acceptable. While turning the plunger, repeat the test several times. If any plunger slides down too quickly (slowly) or jams in the midway, correct it or replace the whole plunger assembly.

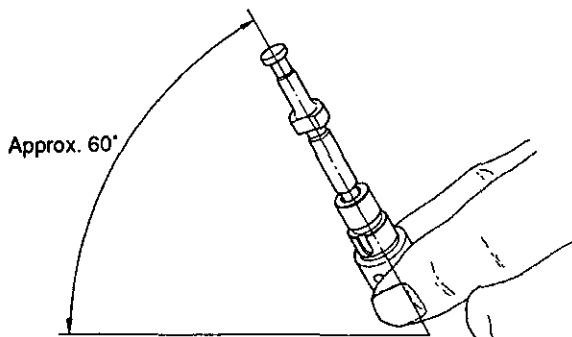

(Fall by gravity test of plunger)

**(4) Delivery valve**

1. If the suck-back collar or seat of the delivery valve is found scratched, dented, worn, or otherwise damaged, replace the whole delivery valve assembly.

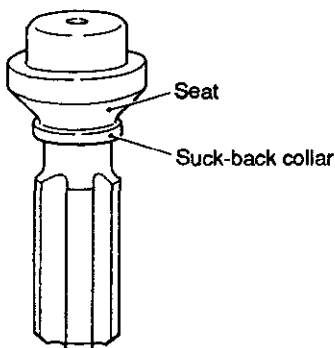

2. Stop up the hole in the bottom of the delivery valve holder and keep the seat as it is. Insert the delivery valve to the holder. While releasing your upper finger, check to see if the delivery valve springs back. If so, it is acceptable.

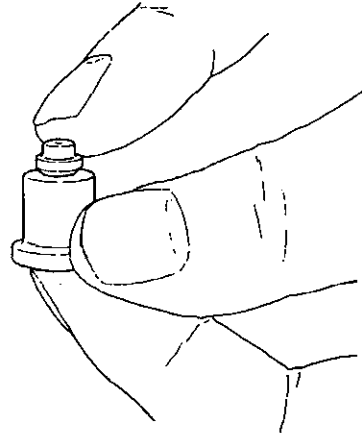

(Inspection of delivery valve)

3. Likewise as described in item 2, stop up the hole in the bottom of the delivery valve holder and check to see if the delivery valve perfectly falls by gravity, when the finger is released from the bottom hole. If so, the delivery valve is acceptable. If not, replace it.

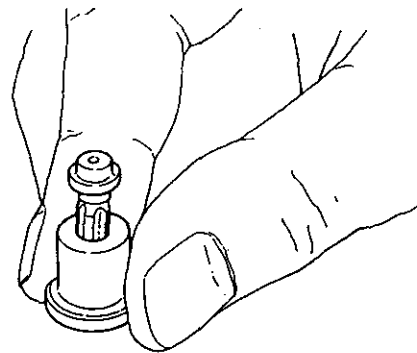

(Fall by gravity test of delivery valve)

### 11-4. Reassembly

- (1) Insert the plunger barrel packing into the fuel injection pump body.
- (2) Insert the plunger barrel assembly.

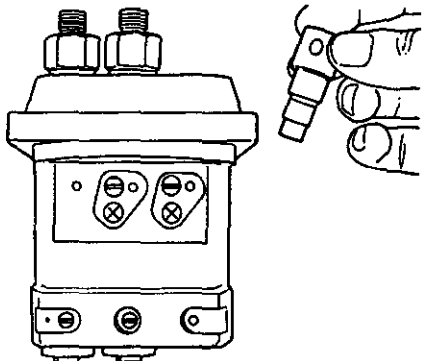

- (5) Fit the plunger mounted with the plunger spring upper retainer, plunger spring and plunger spring lower retainer.
  - \* Ensure that the match mark of the plunger aligns with that of the fuel control pinion.

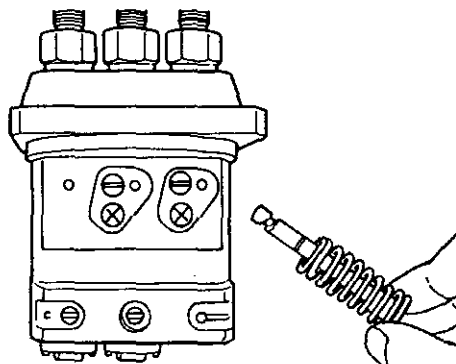

- (3) Fit the delivery valve assembly, delivery valve spring and delivery valve spring holder.

(kgf-m)

Delivery valve spring holder tightening torque.	4.0 ~4.5
---	----------

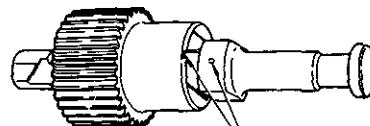

Matching marks

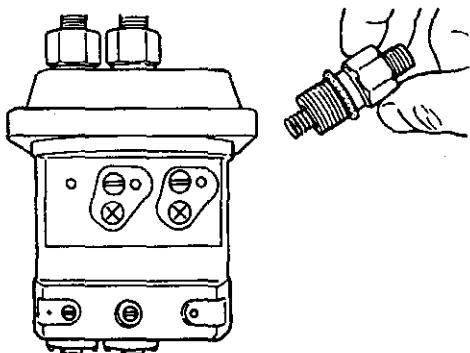

- (6) Insert the plunger adjusting shim. Press the plunger guide assembly by hand. While aligning the plunger guide stopper pin with the mating hole of the stopper pin of the fuel injection pump body, attach the plunger guide stopper pin.

- (4) Reassemble the fuel control rack and fuel control pinion.

- \* 1. Ensure that the match mark of the fuel control rack aligns with that of the fuel control pinion.
- \* 2. Make sure that the fuel control rack moves smoothly over all the strokes.

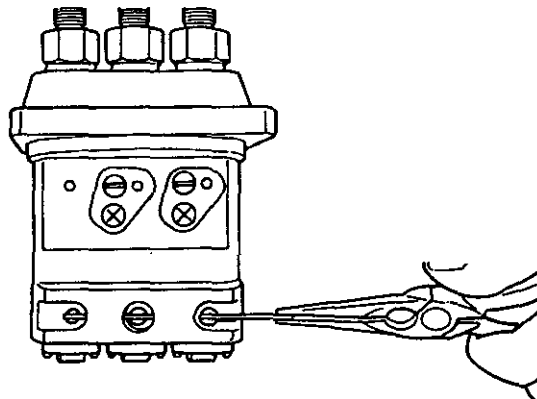
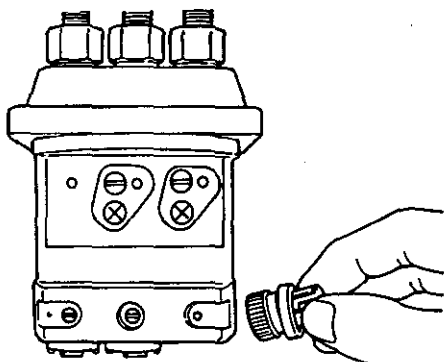
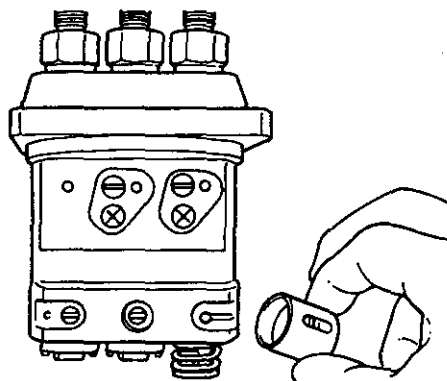

# 12. Fuel Injection Pump for Direct Injection System

## 12-1. Exploded view (YPES type)

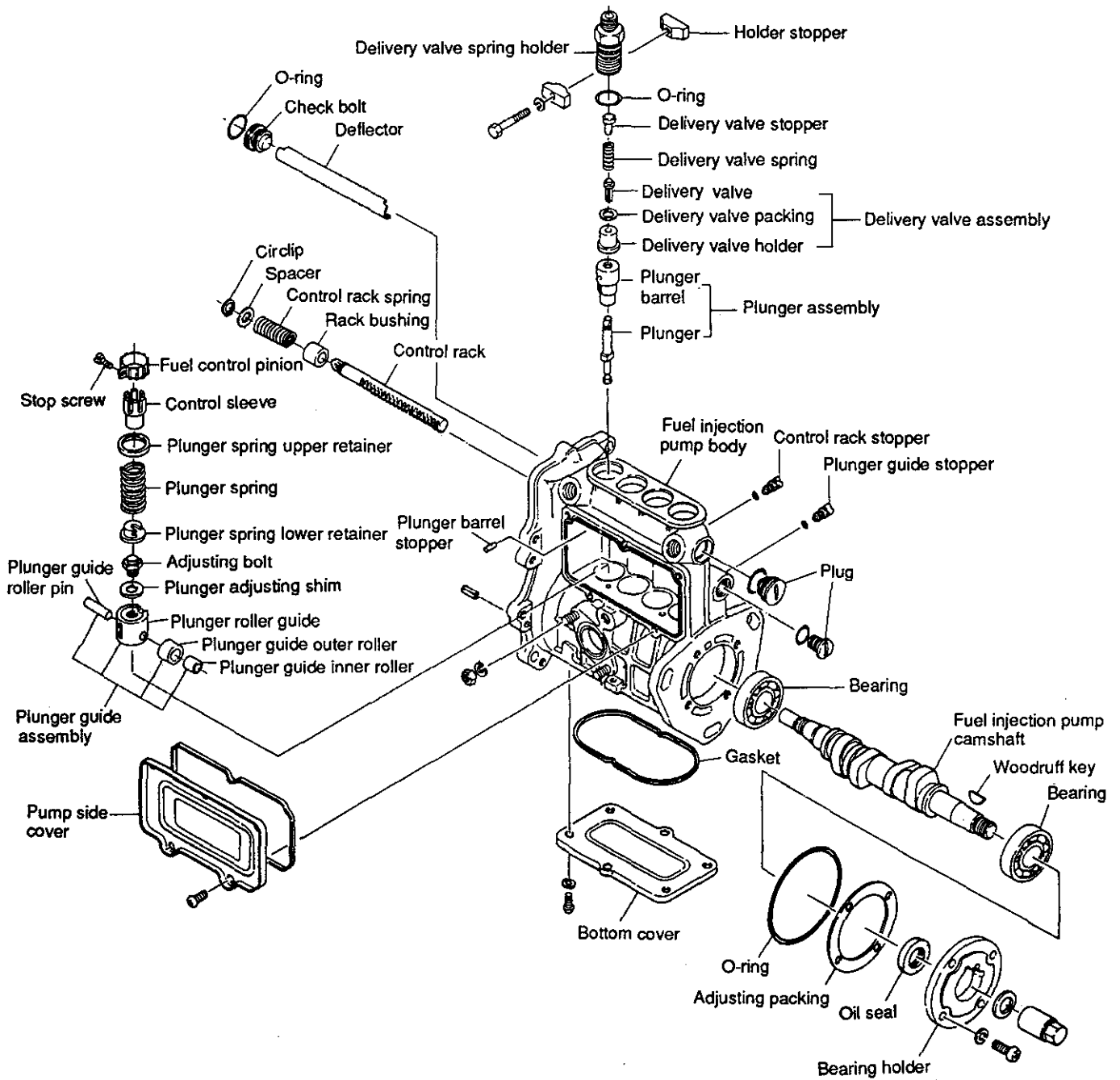

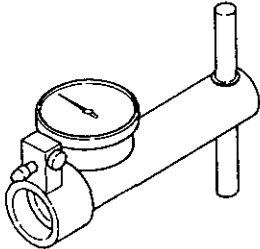
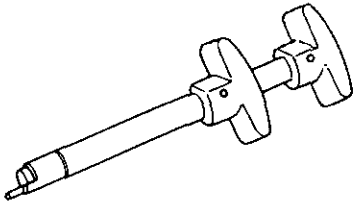
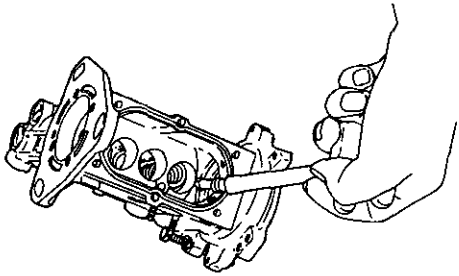
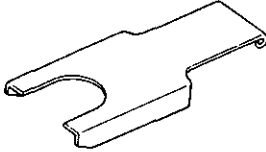
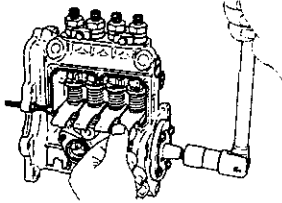
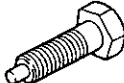
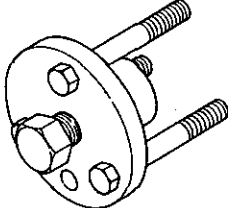
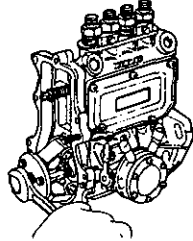

## 12-2. Special service tools for disassembly and reassembly

No.	Name of tool	Shape and size	Application						
1	Side clearance measuring gauge <table border="1" style="margin-left: 20px;"> <tr> <td>Yanmar code No.</td> <td>158090-51050</td> </tr> </table>	Yanmar code No.	158090-51050		Measurement of camshaft side clearance				
Yanmar code No.	158090-51050								
2	Plunger insertion tool <table border="1" style="margin-left: 20px;"> <tr> <td>Yanmar code No.</td> <td>158090-51100</td> </tr> </table>	Yanmar code No.	158090-51100						
Yanmar code No.	158090-51100								
3	Tappet holder tool <table border="1" style="margin-left: 20px;"> <tr> <td>Yanmar code No.</td> <td>158090-51200</td> </tr> </table>	Yanmar code No.	158090-51200						
Yanmar code No.	158090-51200								
4	Rack lock screw <table border="1" style="margin-left: 20px;"> <tr> <td>Yanmar code No.</td> <td>158090-51510</td> </tr> </table>	Yanmar code No.	158090-51510						
Yanmar code No.	158090-51510								
5	Governor weight extractor tool <table border="1" style="margin-left: 20px;"> <tr> <td></td> <td>Yanmar code No.</td> </tr> <tr> <td>Governor weight for 3 pcs.</td> <td>158090-51400</td> </tr> <tr> <td>Governor weight for 4 pcs.</td> <td>158090-51450</td> </tr> </table>		Yanmar code No.	Governor weight for 3 pcs.	158090-51400	Governor weight for 4 pcs.	158090-51450		
	Yanmar code No.								
Governor weight for 3 pcs.	158090-51400								
Governor weight for 4 pcs.	158090-51450								

### 12-3. Disassembly

- (1) Remove the bottom cover from the fuel injection pump to drain lubricating oil from the fuel injection pump.
- (2) Turn the fuel injection pump upside down to drain fuel oil.

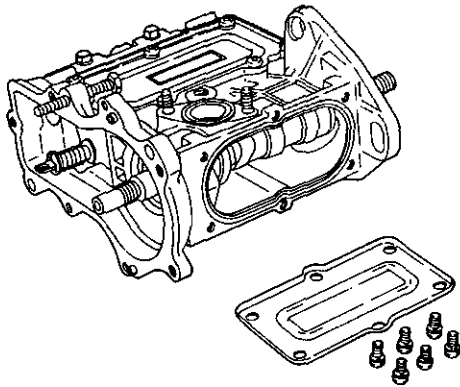

- (4) Remove the fuel feed pump.

\* Do not disassemble the fuel feed pump.

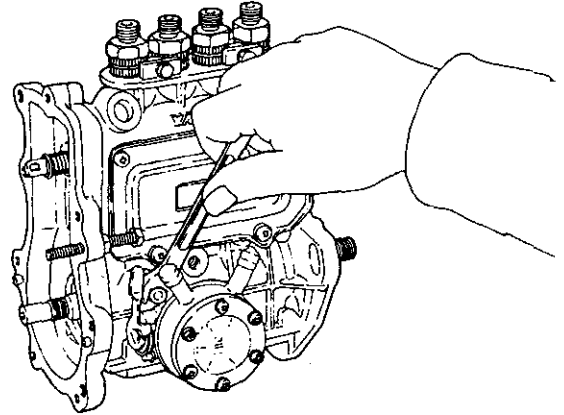

- (3) Take out the governor weight assembly using the governor weight extractor tool (special service tool)

\* For separating the governor assembly from the fuel injection pump, refer to Chapter 13, 13-3.

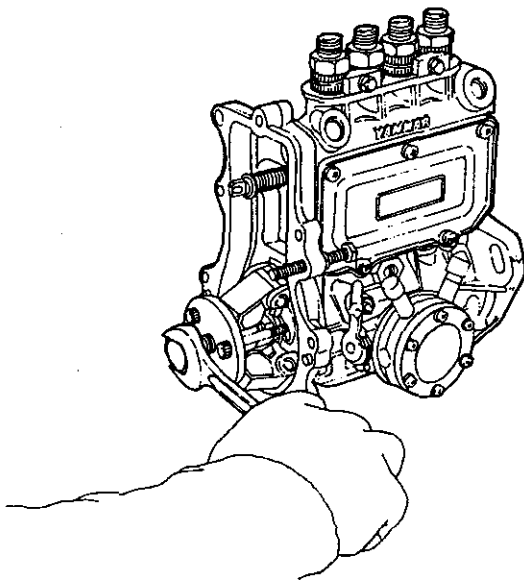

- (5) Remove the fuel injection pump side cover.

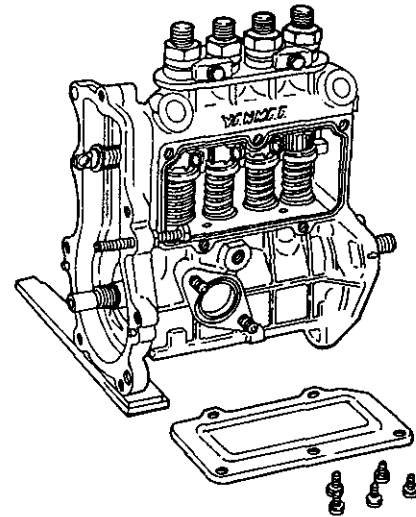

- (6) While turning the fuel injection pump camshaft, raise the plunger guide up to the max. stroke. Insert the tappet holders (special service tool) between the plunger spring lower retainer and fuel injection pump body.

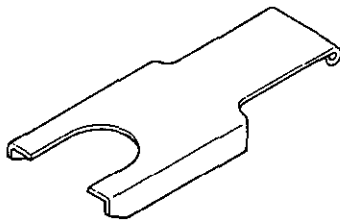
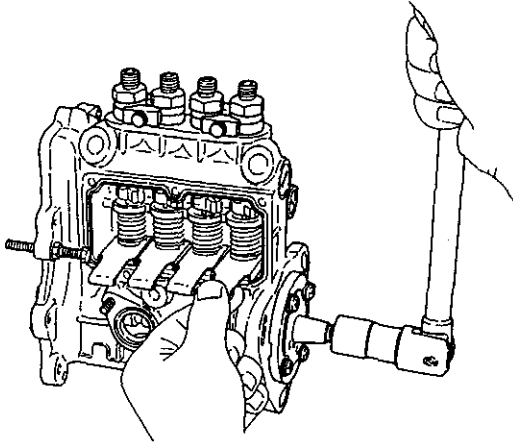

(Special service tool: Tappet Holder)

- (7) Extract the woodruff key from the fuel injection pump camshaft.
- (8) Extract the fuel injection pump camshaft bearing horizontally by inserting a screwdriver into the two grooves on the face where the bearing holder of the fuel injection pump camshaft is installed.

- \*1. Carefully avoid allowing the thread of the fuel injection pump camshaft to damage the oil seal.
- \*2. Carefully avoid allowing the adjusting packings and oil seal between the pump body and bearing holder to be lost.

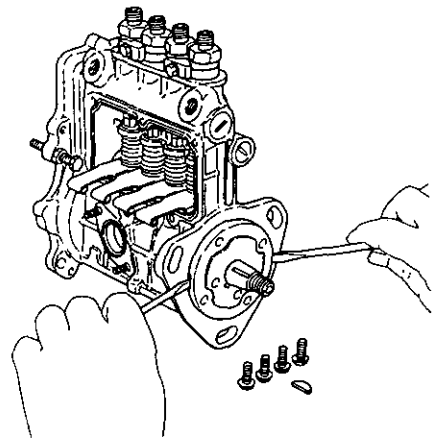

- (9) Turn the fuel injection pump upside down. Move all plunger guides toward the plunger. Then, turn aside the fuel injection pump. While turning the fuel injection pump camshaft, find a position where the cams of each cylinder does not interfere with the plunger guide outer roller and place the camshaft in the position.
- (10) Apply a plate against the governor end side of the camshaft. While tapping the plate, extract a set of the camshaft and drive bearing.

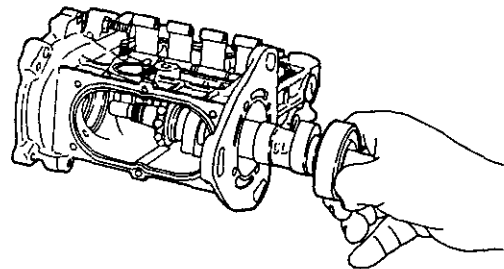

- (11) Remove the plunger guide stopper.

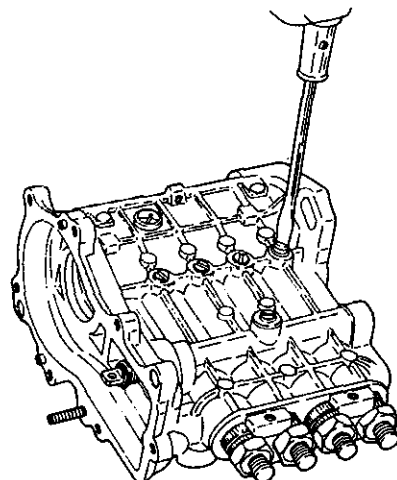

(12) By using the handle of a hammer, etc., push up the plunger guide from the bottom of the pump and take out the tappet holders (special service tool).

\* Use particular care to remove the tappet holder. Carefully prevent the plunger guide, plunger, etc., from jumping out. This is because the plunger spring is powerful enough to force them out.

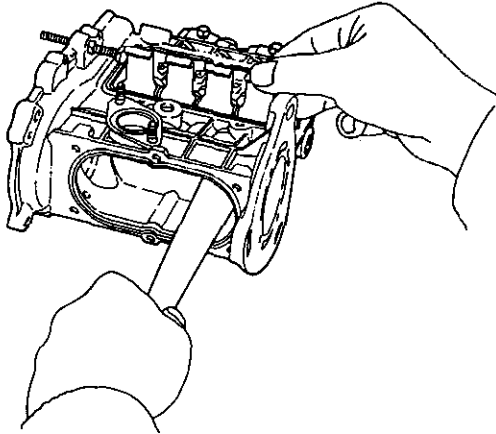

(13) Take out the plunger guide assembly.

\* Do not erect the fuel injection pump body, wherever possible. Otherwise, the plunger guide assembly falls off. Therefore, hold the fuel injection pump body tilted and remove the plunger guide assembly.

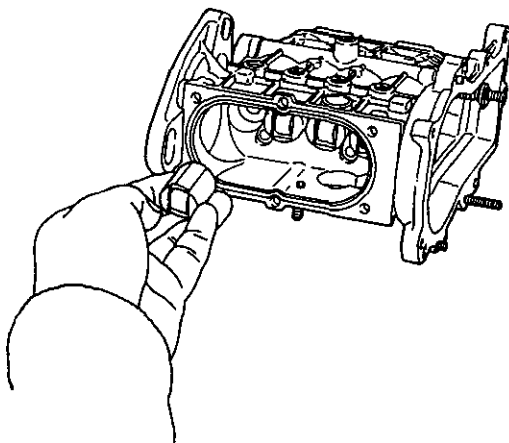

(14) Take out the plunger, plunger spring and plunger spring lower retainer from the lower part of the fuel injection pump.

\* Separate these parts for each cylinder.

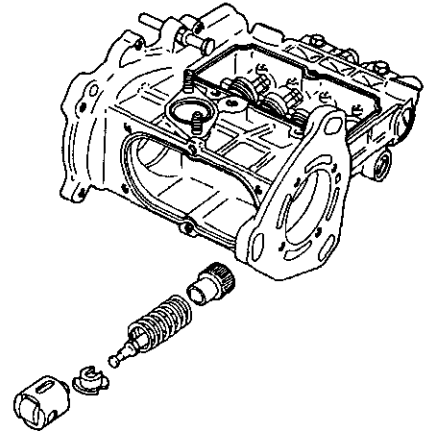

(15) Remove the stop screw from the fuel control pinion.

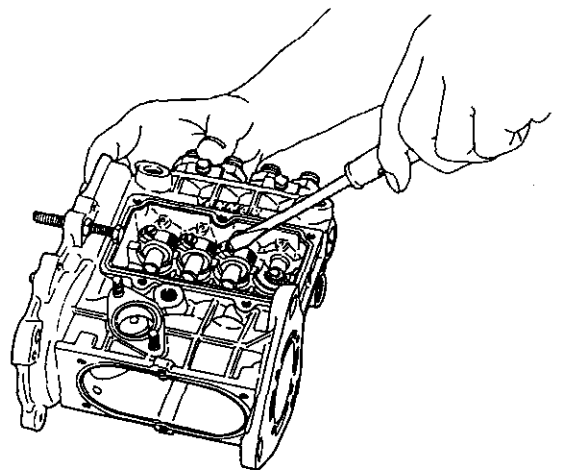

## 12. Fuel Injection Pump for Direct Injection System

- \*1. When the stop screw of the fuel control pinion is loosened, the fuel control pinion is separated from the control sleeve. Before loosening, therefore, make sure that the match mark of the fuel control pinion aligns with that of the control sleeve. If the match mark is difficult to identify or the match mark offsets, put new match marks. This practice helps adjusting injection volume later on.

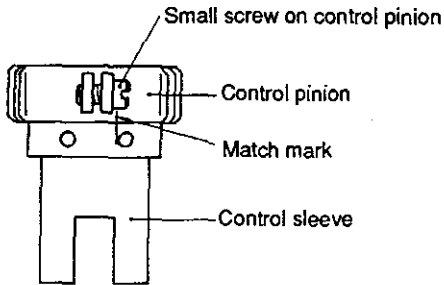

- \*2. Separate all these parts for each cylinder.

- (16) Remove the fuel control pinion, control sleeve and plunger spring upper retainer.

- \*: Separate all these parts for each cylinder.

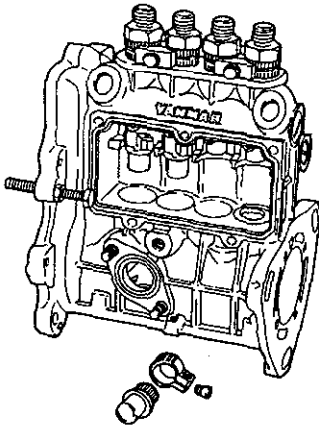

- (17) Remove the control rack stopper. Extract the control rack.

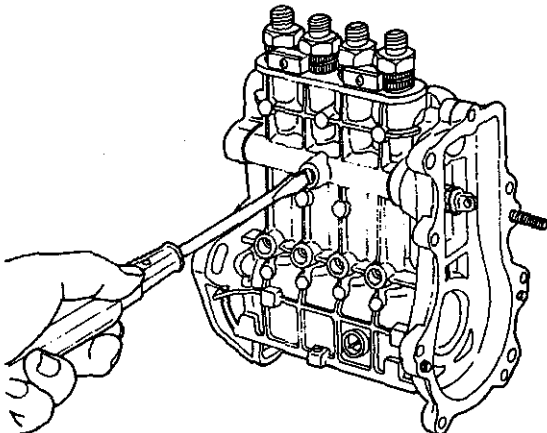

- \* Carefully prevent the control rack spring and spacer on the control rack from being missing.

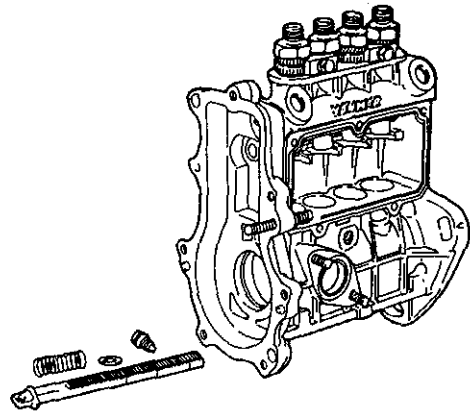

- (18) Loosen the bolt for the holder stopper. Remove the delivery valve spring holder.

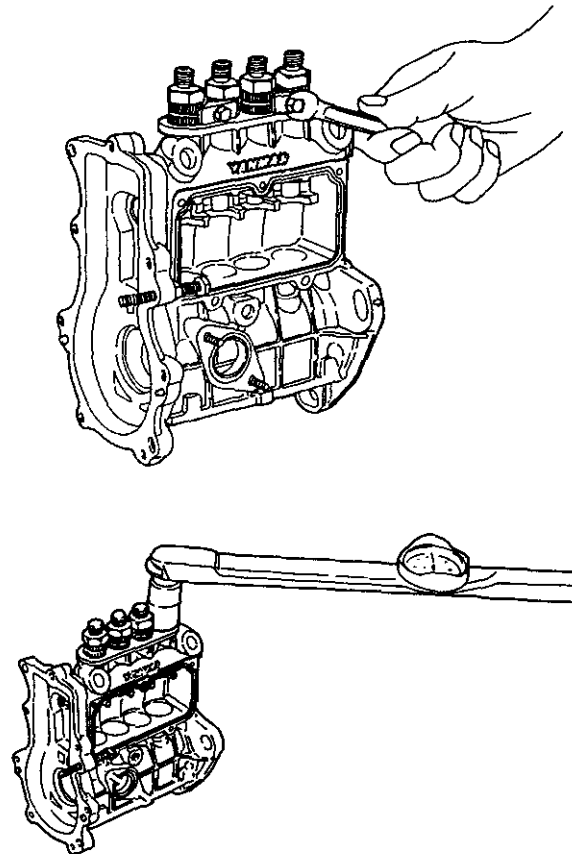

(19) Take out the delivery valve assembly.

- \* 1. Carefully prevent small parts such as the delivery valve packing, delivery valve spring and delivery valve stopper from being missing.
- \* 2. Clearly separate the delivery valve assembly for each cylinder.

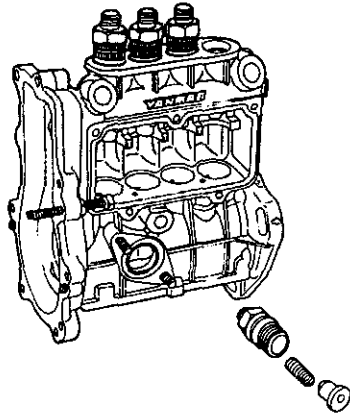

(20) Take out the plunger barrel toward the upper part of the fuel injection pump.

- \* Keep the plunger barrel just picked up together with the plunger which has been taken out.

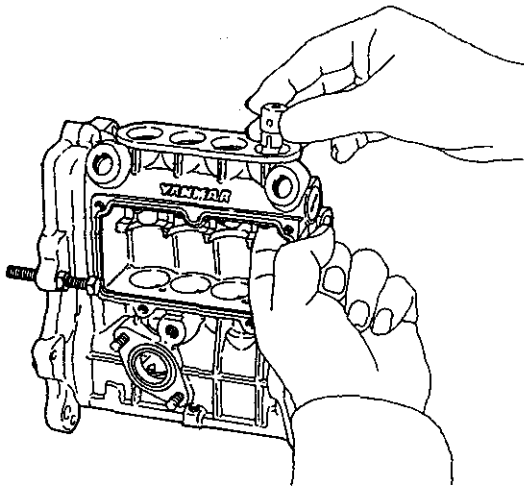

## 12-4. Inspection

Before inspection, thoroughly clean the parts, using new diesel oil. Be careful to avoid damage to the sliding surface of the plunger and delivery valve, etc.

### (1) Plunger

1. Thoroughly clean the plunger. If any plunger lead is scratched or discolored, replace the plunger assembly with a new one.
2. To test the plunger, hold the plunger barrel tilted approx. 60° and check to see if it slides down smoothly. If so, the plunger is acceptable. While turning the plunger, repeat the test several times. If any plunger slides down too quickly (slowly) or jams in the midway, correct it or replace the whole plunger assembly.

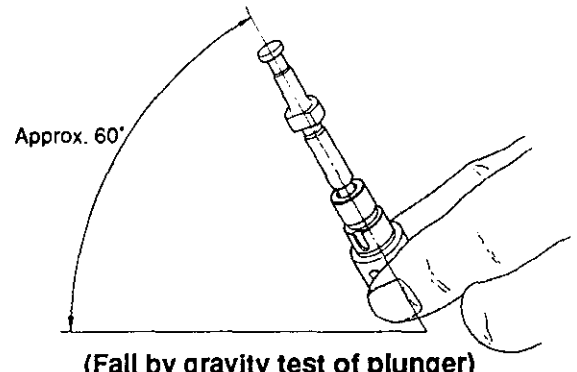

### (2) Delivery valve

1. If the suck-back collar or seat of the delivery valve is found scratched, dented, worn, or otherwise damaged, replace the whole delivery valve assembly.

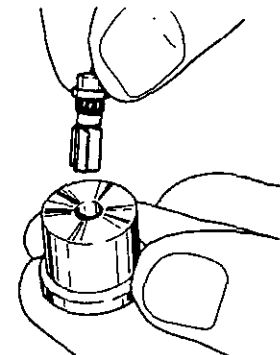

(Check for delivery valve)

2. Stop up the hole in the bottom of the delivery valve holder and keep the seat as it is. Insert the delivery valve into the holder. While releasing your upper finger, check to see if the delivery valve springs back. If so, it is acceptable. If not, replace it.

3. Likewise as described in item 2, stop up the hole in the bottom of the delivery valve holder and check to see if the delivery valve falls by gravity perfectly, when the bottom hole's finger is released. If so, the delivery valve is acceptable. If not, replace it.

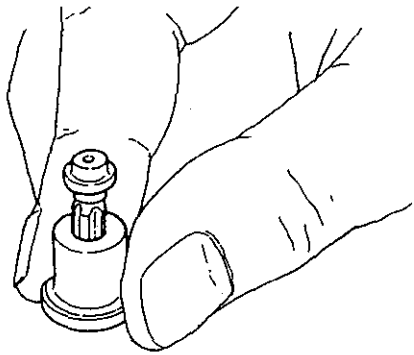

(Fall by gravity test of delivery valve)

**(3) Plunger guide, plunger barrel, etc.**

1. Check to see if the sliding surface of the plunger guide is free from excessive wear.
2. Check to see if the seat of the plunger barrel has uneven contact, burrs, the mark of blow-by gas or other defects etc. If so, correct or replace the plunger barrel. Otherwise, lubricating oil in use will be thinned.
3. If the surface of the plunger guide outer roller indicates wear, flaking, etc., replace the outer roller.
4. If the plunger guide has the circumference and roller pin hole worn or scratched, etc., replace it with a new one.
5. If the plunger guide assembly has a combination of the pin and roller that indicates chatters, replace the plunger guide assembly.

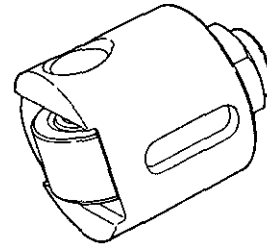

(Plunger guide assembly)

**(4) Fuel injection pump camshaft and bearing**

**1. Fuel injection pump camshaft**

Check for damage and wear of the camshaft surface, deformation of keyway and deformation of threads on both ends. If the camshaft proves to be defective, replace it.

**2. Bearing**

If the taper roller and outer race has flaking, wear, or any other damage on the surface, replace the bearing.

*\* When replacing the fuel injection pump camshaft, replace the bearing at the same time.*

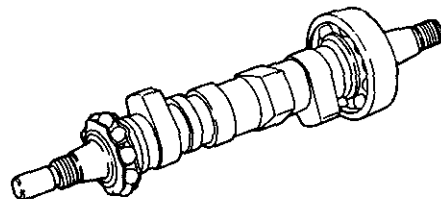

(5) Control rack and fuel control pinion

1. Check the control rack for bends and the wear and deformation of the portion where it is engaged with the fuel control pinion.
2. Check to see if the portion where the control rack is engaged with the fuel control pinion is free from wear and deformation.

\* If the control rack is in trouble with the teeth face and sliding part, it encounters increased resistance, causing the engine to be out of order (such as uneven revolutions and abrupt revolution changes).

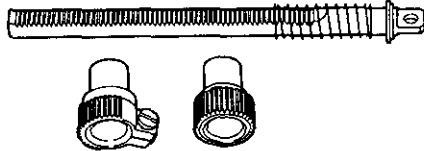

12-5. Reassembly

- (1) Put the plunger barrel into the fuel injection pump from its top.

\* Make sure that the plunger barrel stopper is snugly fitted with the key way.

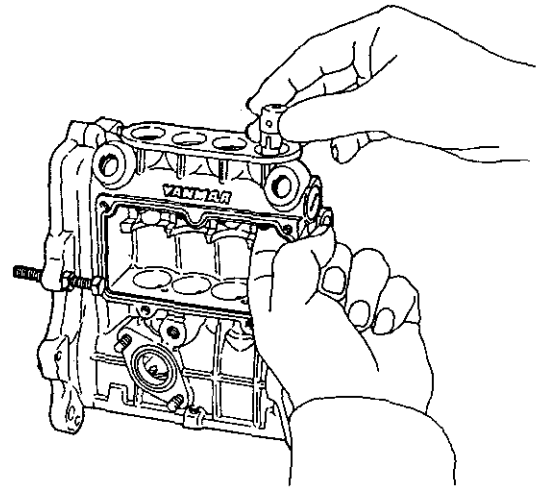

- (2) Insert the delivery valve assembly, delivery valve spring and delivery valve stopper from the top of the fuel injection pump in that order.

\* Replace the delivery valve packing and O-ring with new ones before reassembling the fuel injection pump.

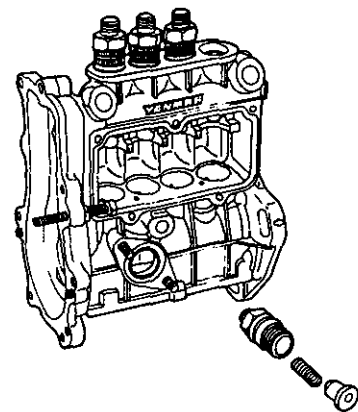

- (3) Fit the control rack and tighten the control rack stopper.

\*1. Never fail to install the control rack spring.  
 \*2. Make sure that the control rack moves smoothly over the full stroke.



## 12. Fuel Injection Pump for Direct Injection System

- (4) Insert a rack lock screw (special service tool) into the thread hole of the control rack stopper and fix the control rack.

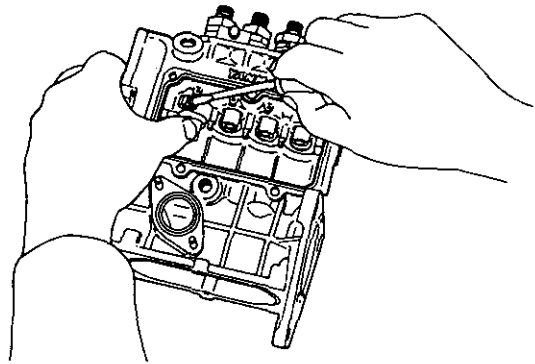
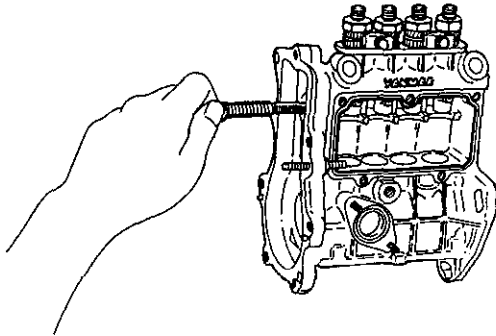

- (5) Peep through the bottom of the fuel injection pump and align the match mark of the control rack with that of the fuel control pinion.

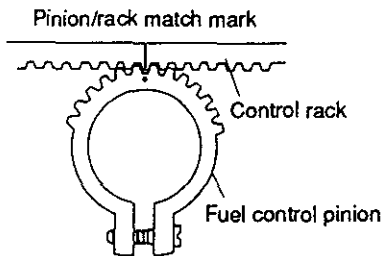

( Matching mark on the control rack )  
and fuel control pinion

- (6) While holding the fuel control pinion by one hand so that its match mark may not be out of position, reassemble the control sleeve and lightly tighten the stop screw of the fuel control pinion.

\* Reassemble the control sleeve in the direction in which the holes around the control sleeve face the stop screw. At the same time, align the match mark with that of fuel control pinion.

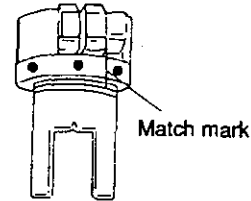

(Fuel control pinion/control sleeve match mark)

- (7) Mount the plunger spring upper retainer

- \*1. Mount the plunger spring upper retainer so that its recess faces downward.
- \*2. Once again, ascertain that the control rack moves smoothly.

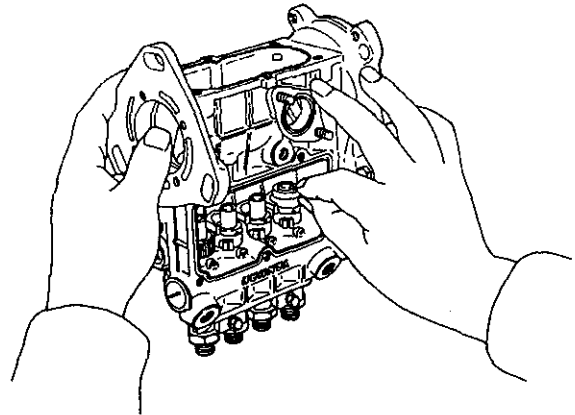

- (8) Mount the plunger spring.

- (9) Mount the plunger spring lower retainer on the top of the plunger. While aligning the match mark of the plunger flange with that of the control sleeve, reassemble the plunger from the bottom of the fuel injection pump using a plunger insertion tool (special service tool).

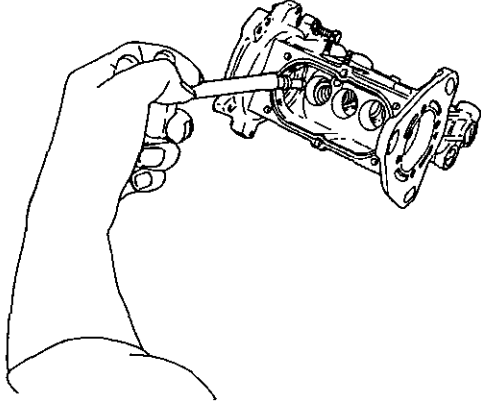

( Insertion of plunger with a special service tool: Plunger insertion tool )

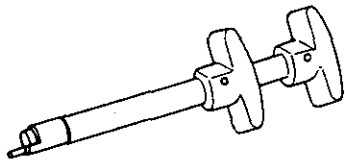

( Special service tool: Plunger insertion tool )

\* Never reassemble the plunger in reverse. Otherwise, fuel injection volume increases excessively to the point where fuel injection volume becomes uncontrollable.

- (10) Insert the plunger guide assembly into the fuel injection pump from its bottom. Push up the plunger guide using the handle of a hammer, etc., and put a tappet holder (special service tool) in between the lower spring retainer and fuel injection pump body.

\*1. While keeping the plunger guide detent groove facing upward, align with the mating screw hole of the plunger guide stopper on the fuel injection pump body.

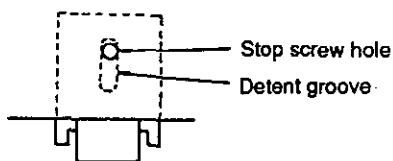

- \*2. Check to see if the control rack moves freely. If not, the plunger spring interferes with something else. In this case, hold the plunger spring in position using a screwdriver.
- \*3. When replacing the plunger guide assembly with a new one, insert the standard shim, and temporarily tighten it.

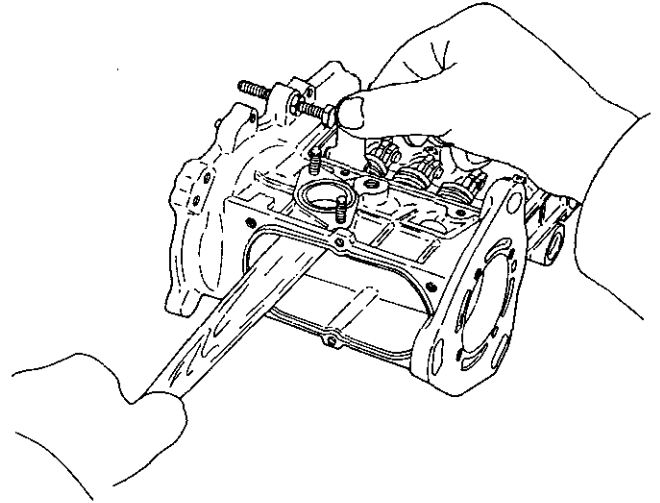

- (11) Make sure that the plunger guide detent groove is in position. Tighten the plunger guide stopper.

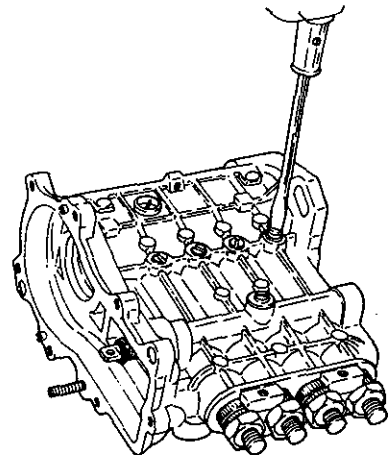

**12. Fuel Injection Pump for Direct Injection System**

(12) Place the bearings on both ends of the fuel injection pump camshaft. Insert the bearings while tapping them from driving side.

\* Turn the fuel injection pump upside down. Move the plunger guide toward the plunger spring and drive in the fuel injection pump camshaft.

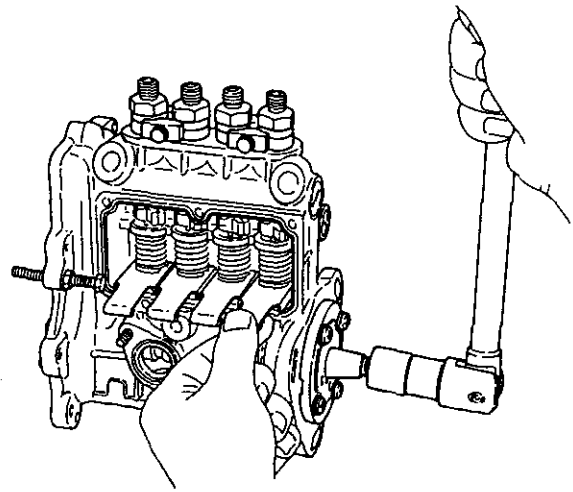
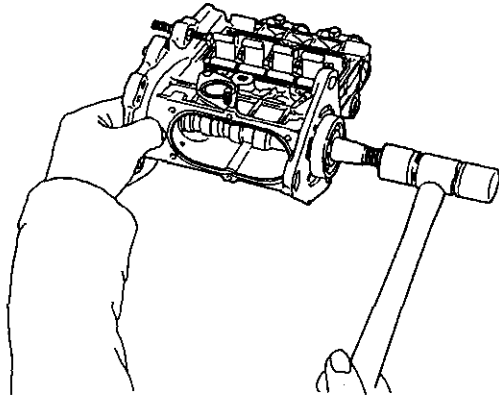

(13) Fit the oil seal to the inner side of the bearing holder. Mount the bearing holder.

\* Apply lubricating oil to the fuel injection pump camshaft and oil seal of the fuel injection pump camshaft in advance so as not to damage the oil seal.

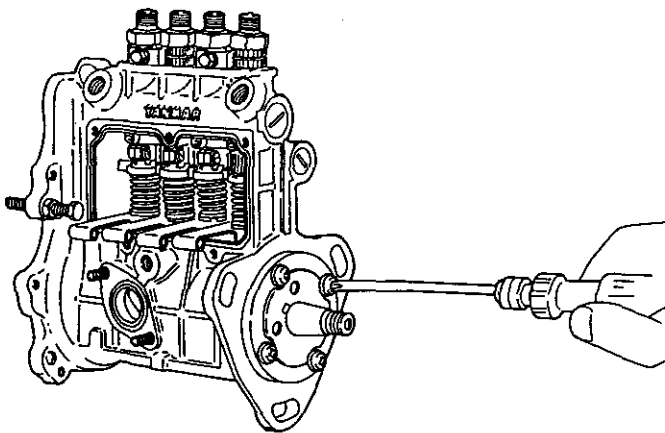

(14) Drive the woodruff key into the fuel injection pump camshaft.

(15) Turn the fuel injection pump camshaft, and extract the tappet holder (special service tool).

(16) Fix the fuel injection pump. Using a mallet, tap the end of the fuel injection pump camshaft to adjust the side clearance of the fuel injection pump camshaft using an adjusting packing and a side clearance gauge (special service tool).

(mm)

	All models
Camshaft side clearance	0.02 ~ 0.05

**[Adjustment Procedure]**

If a clearance is found small, remove the adjusting packing.

If a clearance is found large, add one or more adjusting packing.

Thickness of adjusting packing : 0.5, 0.4, 0.3, and 0.15 mm.

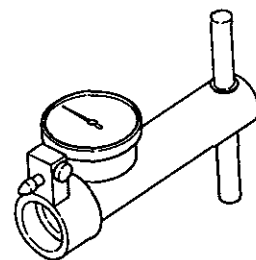

( Special service tool: Side clearance gauge )

(17) Mount the fuel injection pump side cover.

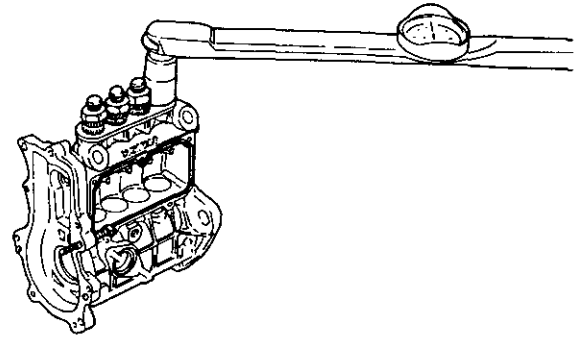
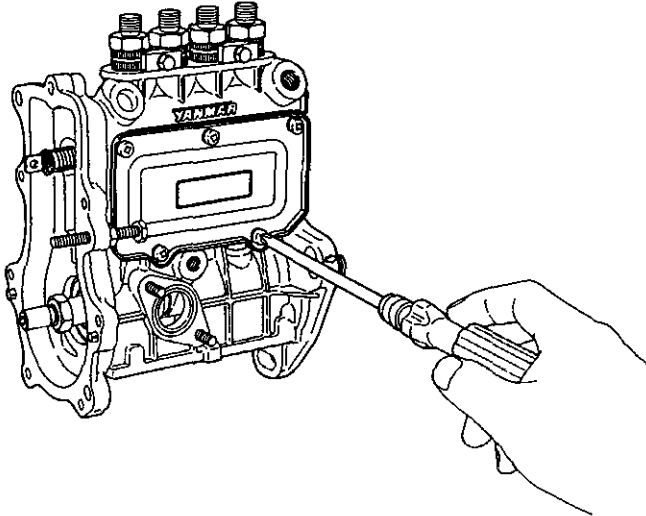

(20) Tighten the holder stopper to the specified torque.

(kgf-m)

	All models
Tightening torque	0.3

(18) Mount the fuel injection pump bottom cover.

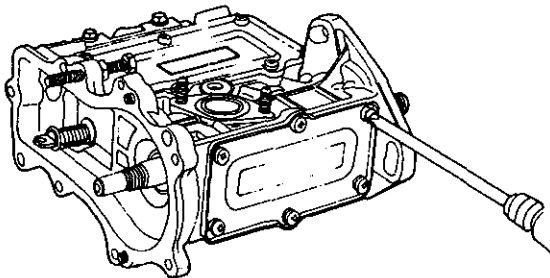

(19) Tighten the delivery valve spring holder to the specified torque.

(kgf-m)

	All models
Tightening torque	3.5 ~ 4.0

\* Never tighten the delivery holder excessively. Otherwise, it upsets, causing oil to leak through it.

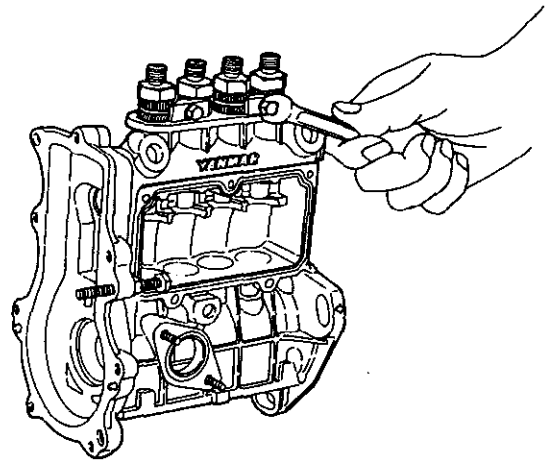

(21) Mount the fuel feed pump.

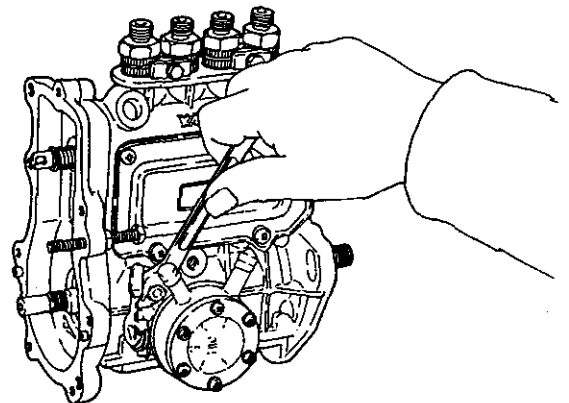

- \*1. Tighten the delivery valve spring holder by hand as far as possible. If the bolt get hard to turn part way, the packing or delivery valve may be out of position. Remove, correct, and start tighten again.
- \*2. Never tighten the delivery valve holder excessively. Excessive tightening causes the control rack to malfunction.

# 13. Governor

## 13-1. Exploded views of governor for indirect injection system

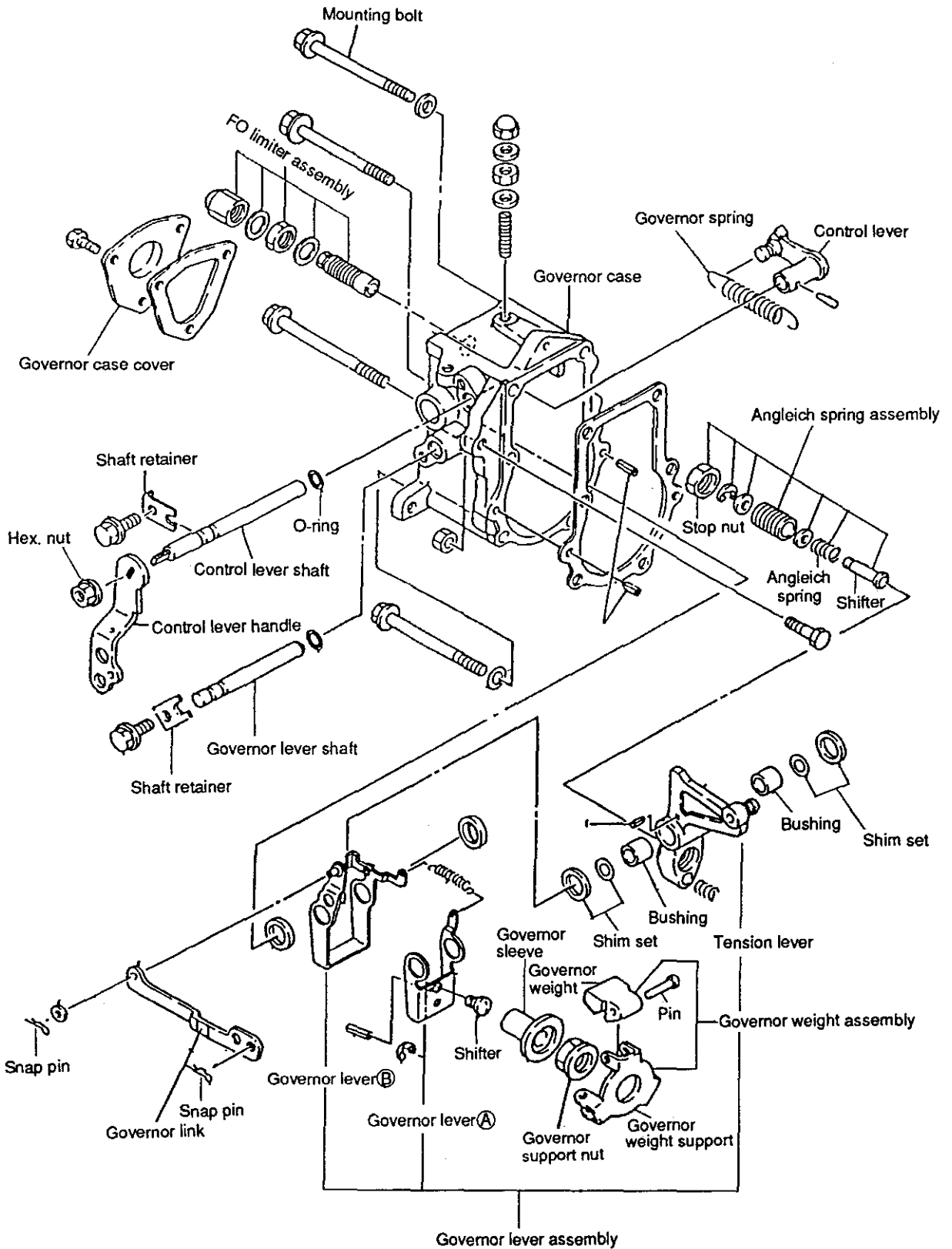

### 13-2. Exploded views of governor for direct injection system

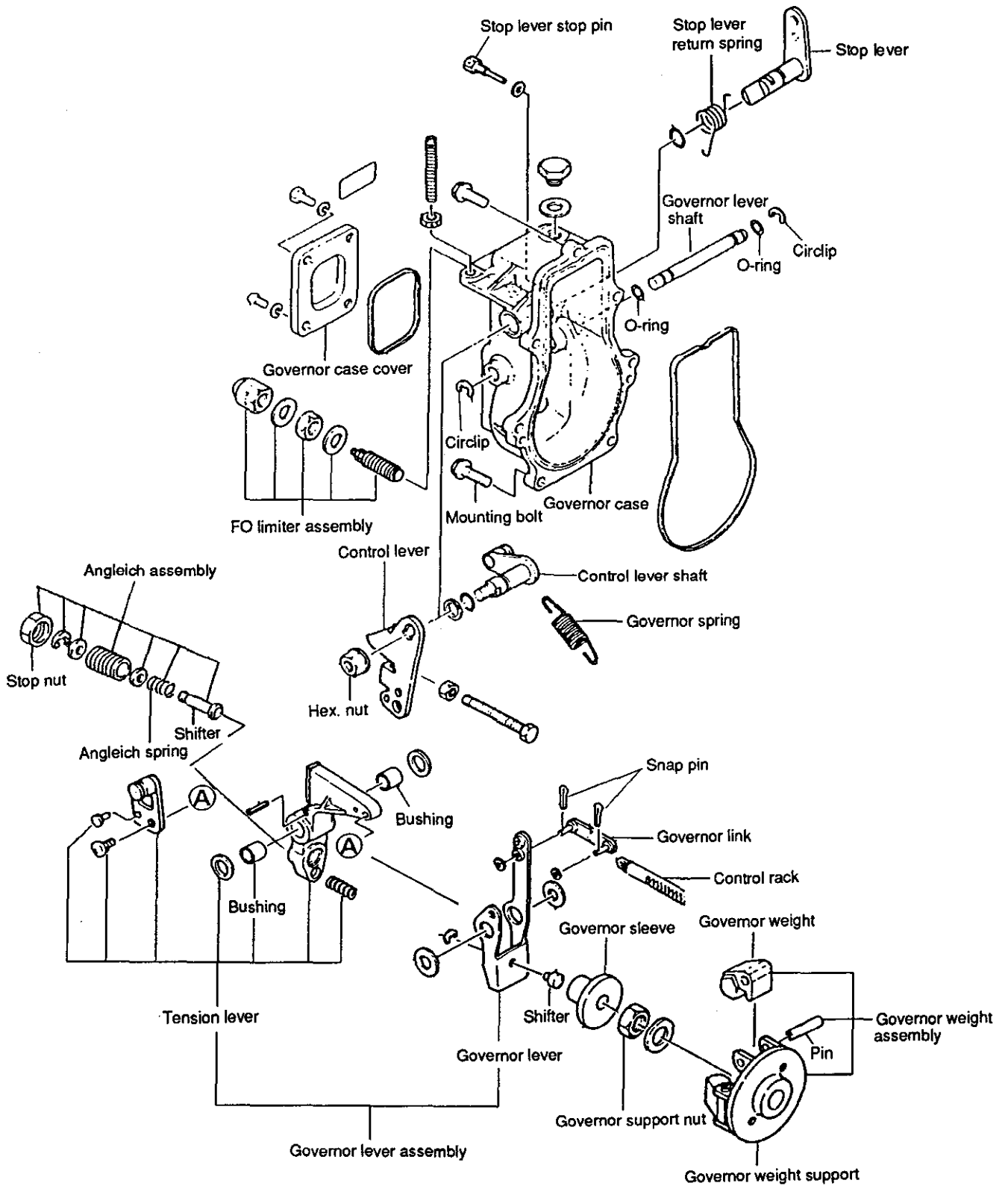

### 13-3. Disassembly

Disassembly and reassembly can be carried out similarly for Indirect injection system and Direct injection system.

- (1) Remove the governor case.

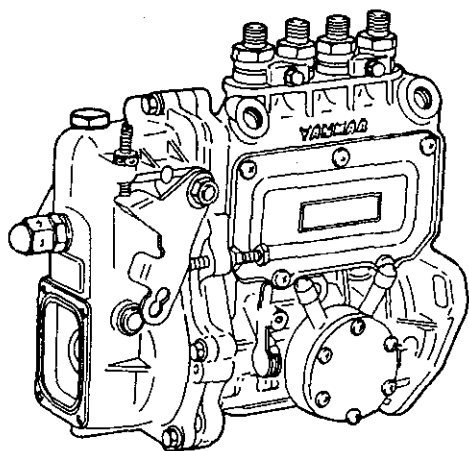

\* Loosen the stop nut on models with angleich assembly.

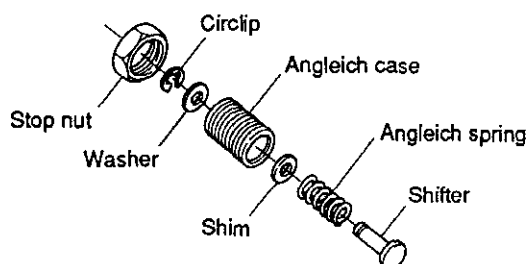

(Angleich assembly)

- (2) Remove the control lever hex. nut and pull out the control lever from the control lever shaft.

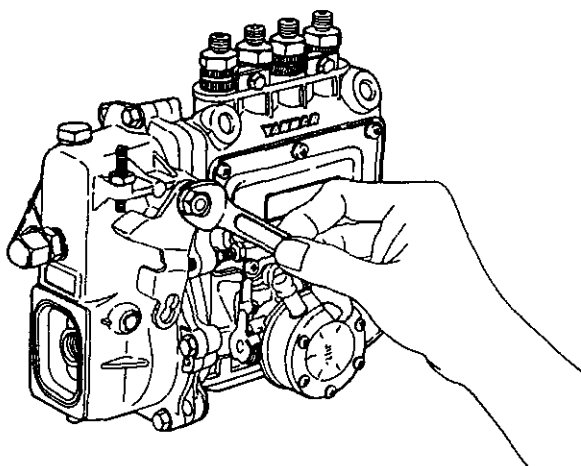

- (3) Remove the governor case mounting bolt. Remove the governor case from the fuel injection pump while gently tapping the governor case with a wooden hammer. Create a gap between the governor case and fuel injection pump by moving only the moving parts of the governor lever.

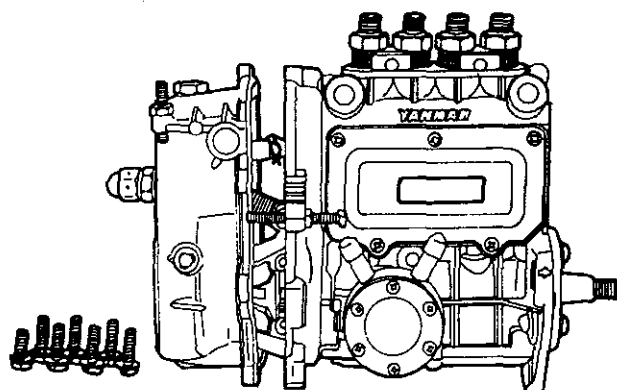

- (4) Pull out the governor link snap pin by inserting long nosed pliers between the fuel injection pump and governor case.

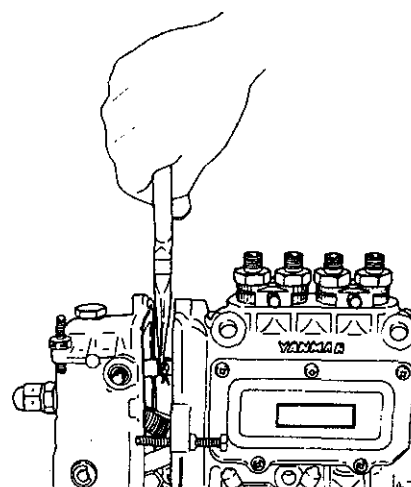

### 13. Governor

- (5) Separate the governor and fuel injection pump by sliding the governor case and fuel injection pump apart and pulling out the snap pin of the governor link from the control rack.

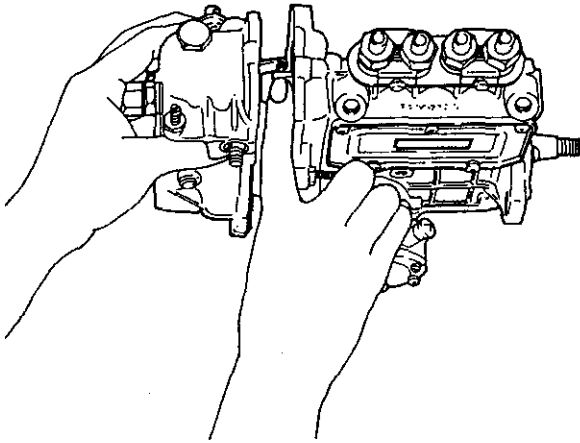

- (7) Use long nosed pliers to unhook the governor spring from the tension lever and control lever shaft.

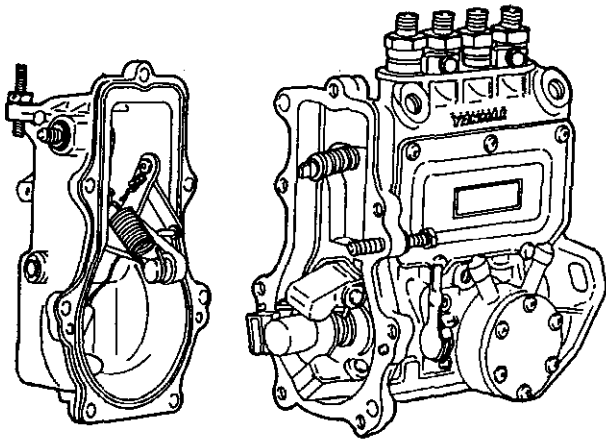
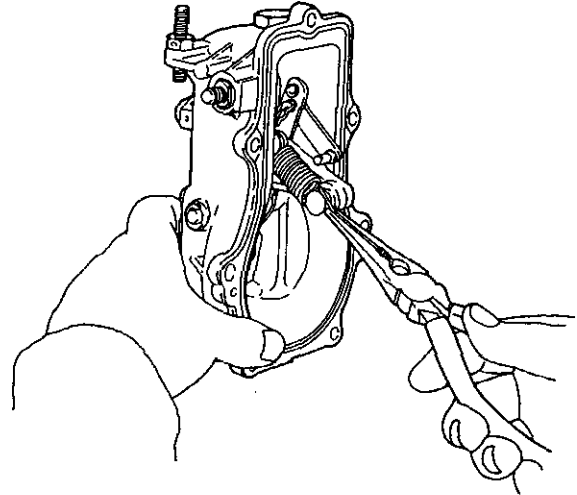

- (8) Remove the shaft retainer on the governor lever shaft. (for IDI)  
Remove the circlips on both ends of the governor lever shaft. (for DI)

- (6) Remove the stop lever return spring from the governor lever shaft. (DI only)

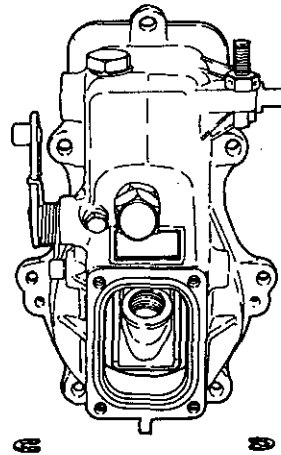
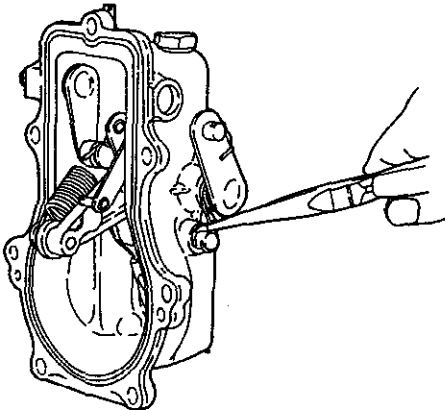



- (9) Put a rod 8 mm in dia. or less in one end of the governor lever shaft and tap the governor lever shaft until the O-ring comes out the other side of the governor case.

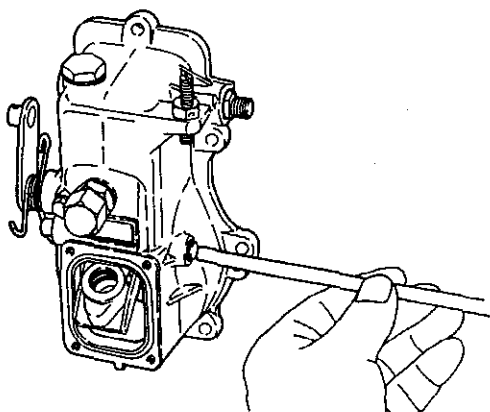

- (10) After you remove the O-ring, lightly tap the end of the shaft that you removed the O-ring from, and extract the governor lever shaft.

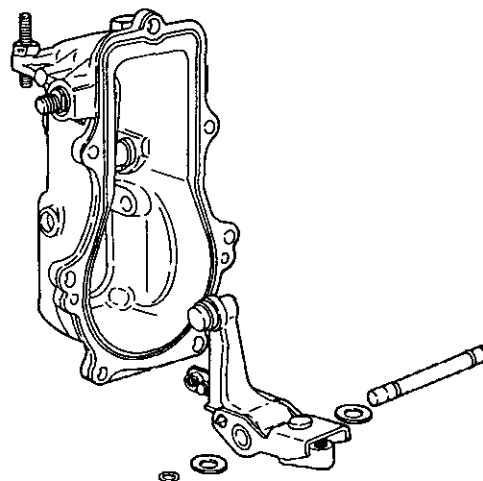
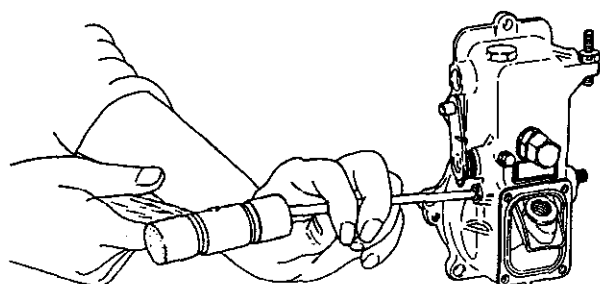
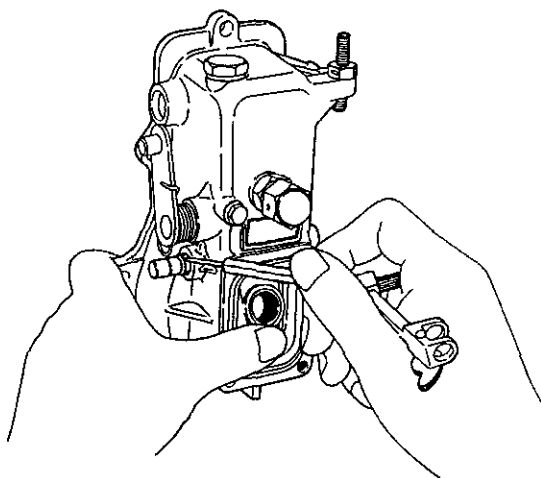

- (11) Remove the governor link from the governor lever.

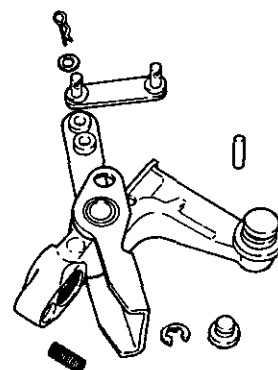
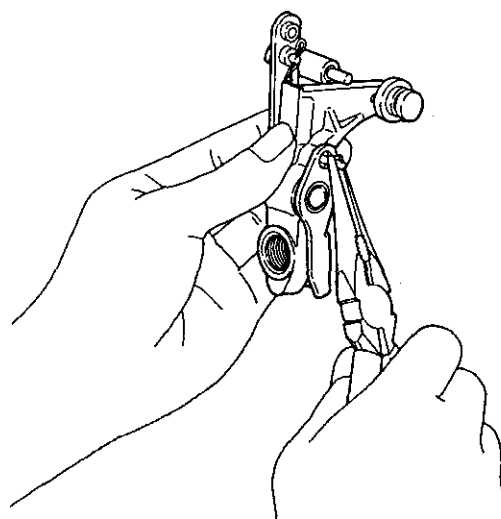

\* The governor assembly consists of the governor lever, tension lever and angleich, and is normally not disassembled.

### 13. Governor

- (12) When you need to pull out the stop lever, remove the stop lever shaft stop pin, and lightly tap the inside of the governor case. (DI only)

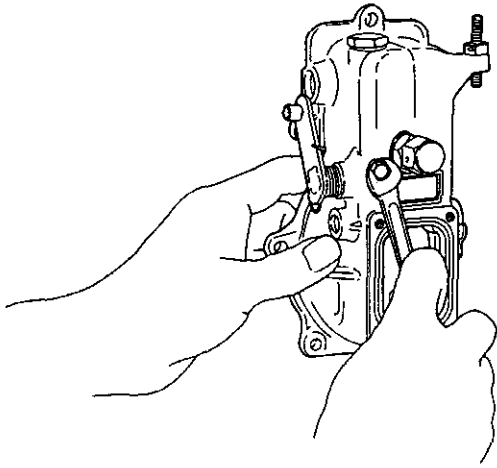

- (13) When you need to pull out the control lever shaft, lightly tap the end of the shaft with a wooden hammer, and extract the control lever.

- \*1. Do not remove the FO limiter assembly from the governor case unless necessary.
- \*2. On models with torque springs, first remove the box nut, stop nut, and then the torque spring assembly.

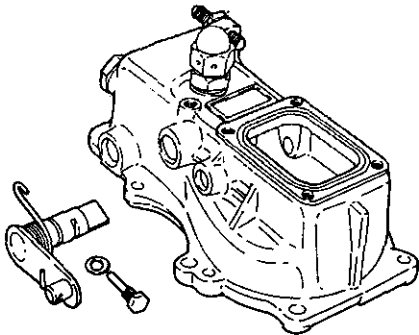

- (14) Pull out the governor sleeve on the end of the fuel injection pump camshaft by hand.

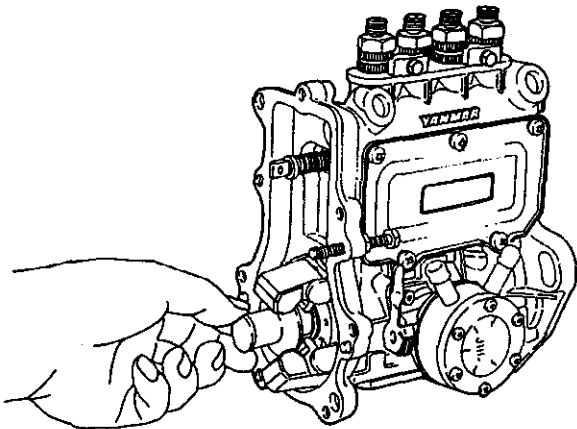

- (15) Fix the bearing holder with a vise to hold the fuel injection pump camshaft. Loosen the governor support nut with a box spanner a few turns.

- \* When the taper fit comes apart after you have removed the nut, the governor weight may fly out - Be careful.

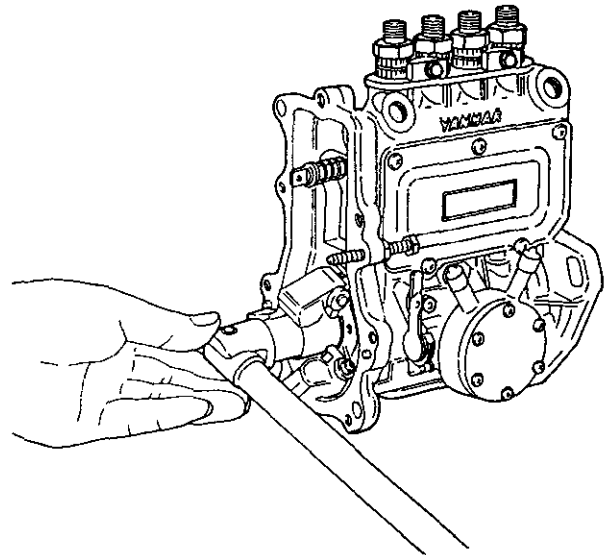

- (16) Remove the governor weight assembly from the fuel injection pump camshaft using the governor weight extractor (special service tool).

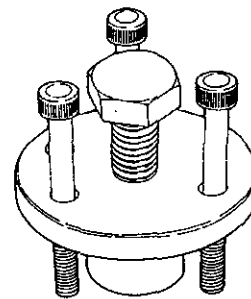

(Governor weight extractor)

## 13-4. Inspection

### 1. Inspection of governor weight assembly

- (1) Replace the governor weight if it does not open and close smoothly.

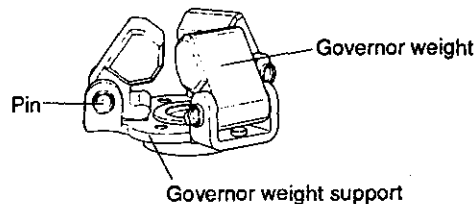

- (2) Replace the governor weight assembly if the contact surface with governor sleeve is extremely worn.
- (3) Replace if there is governor weight support and pin wear or the the caulking is loose.
- (4) Replace if the governor weight support stopper is excessively worn.

### 2. Inspection of governor sleeve

- (1) Replace the governor sleeve if the contact surface with governor weight is worn or there is pitching.
- (2) Replace the governor sleeve if the contact surface with shifter is excessively worn or there is pitching.
- (3) If the governor sleeve does not move smoothly on the fuel injection pump camshaft due to governor sleeve inner dia. wear or other reasons, replace.

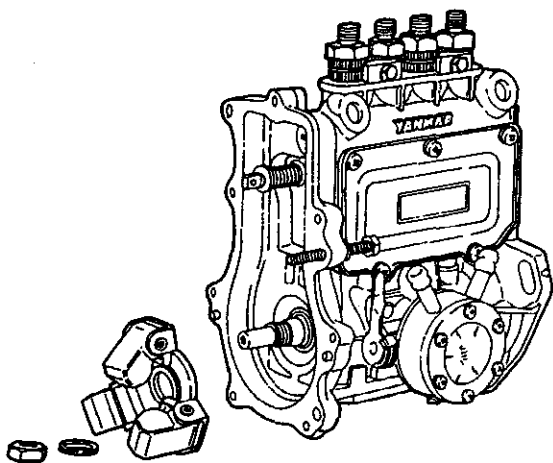
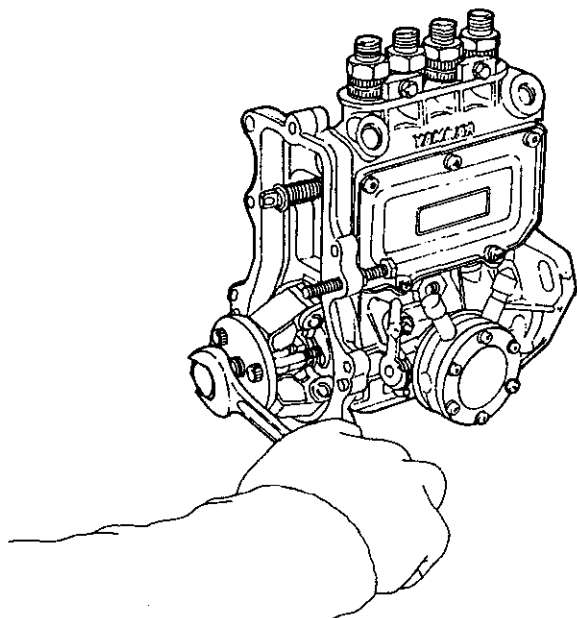
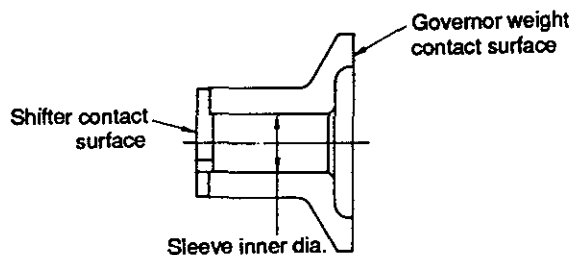

### 3. Inspection of governor lever shaft assembly

- (1) Measure the clearance between the governor lever shaft and bushing, and replace if it is near the wear limit.

(mm)

	Standard dimension	Standard clearance	Limit
Governor lever shaft outer dia	8 <sup>-0.005</sup> <sub>-0.014</sub>	0.065 ~0.124	0.5
Bushing inner dia.	8 <sup>+0.11</sup> <sub>+0.06</sub>		

- (2) Inspect the shifter contact surface, and if it is worn or scorched, remove the spring pin to disassemble and replace the shifter only.
- (3) Check link parts for bends or kinks that will cause malfunctioning, and replace if it is faulty.

\*1. Side gap on top of governor lever shaft.

(mm)

Standard side gap	0.4
-------------------	-----

2. Replace the governor lever, tension lever, bushing, shifter and angleich spring as an assembly.

### 4. Inspection of springs

- (1) Check the governor spring and other springs and replace if they are broken, settled or corroded.

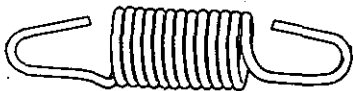

### 5. Inspection of angleich spring assembly

- (1) Inspect the sliding surface of shifter and replace if it is faulty.
- (2) Replace the angleich spring assembly if the angleich spring is broken.

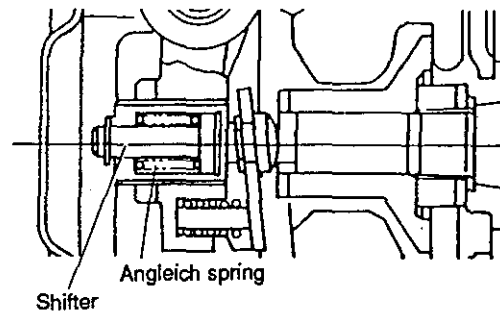

### 6. Inspection of torque spring assembly

- (1) Inspect the tip of the piston and contact surface for wear and replace if it is faulty.
- (2) Replace the assembly if the torque spring is broken.

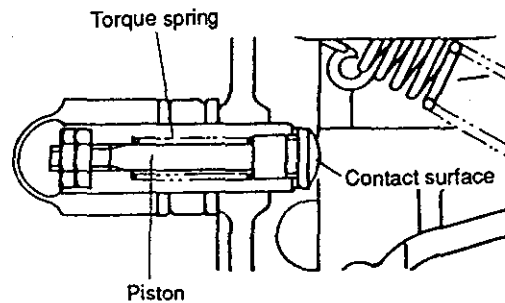

## 13-5. Reassembly

Inspect all parts after disassembly and replace any parts as necessary. Before starting reassembly, clean all parts and put them in order.

Make sure to readjust the unit after reassembly to obtain the specified performance.

- (1) Fix the bearing holder with a vise to hold the fuel injection pump camshaft. Insert the governor weight assembly in the taper portion at the end of the fuel injection pump camshaft. Mount the washer, and tighten the governor weight support nut with the specified torque.

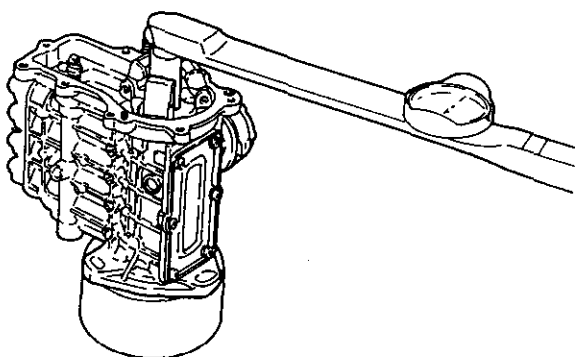

(kgf-m)

	Governor weight support nut tightening torque
Indirect injection system	7.0 ~ 7.5
Direct injection system	4.5 ~ 5.0

- (2) Open the governor weight to the outside, and insert the sleeve in the end of the fuel injection pump camshaft.

\* Make sure that the sleeve moves smoothly after inserting it.

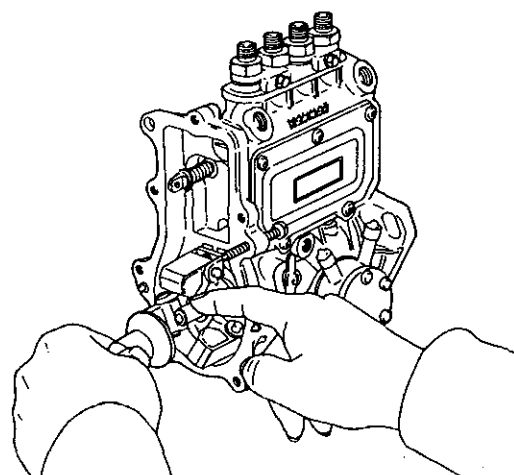

- (3) After the stop lever is disassembled, mount the stop lever return spring on the stop lever, tap the stop lever lightly with a wooden hammer to insert it, and tighten the stop lever stop pin. (DI only)

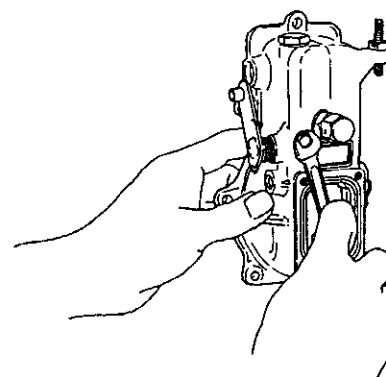

- (4) After the control lever shaft is removed, lightly tap and insert the control lever shaft and washer from inside the governor case, using an appropriate plate.
- (5) If the governor lever has been disassembled, tap in the spring pin.

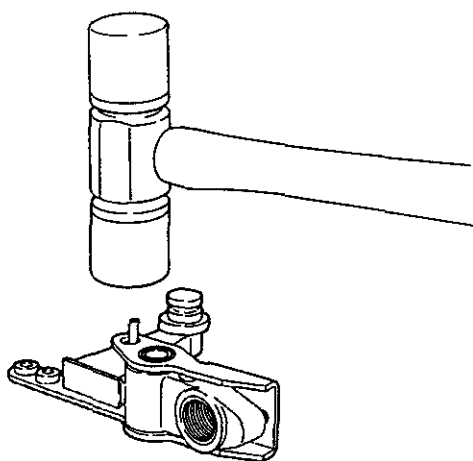

(6) Mount the governor lever assembly to the governor link.

- \*1. Make sure that the correct governor link mounting holes are used and that it is mounted in the correct direction.
- \*2. Make sure that the governor link moves smoothly.

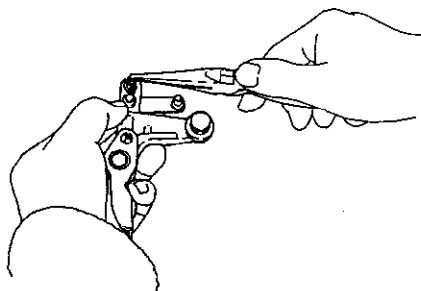

(7) Put the governor lever shaft assembly in the governor case, insert the governor lever shaft and tap it in until the O-ring groove comes out the opposite side of the governor case. (for DI)

- \*1. Fit the O-ring beforehand to the side you tap in.

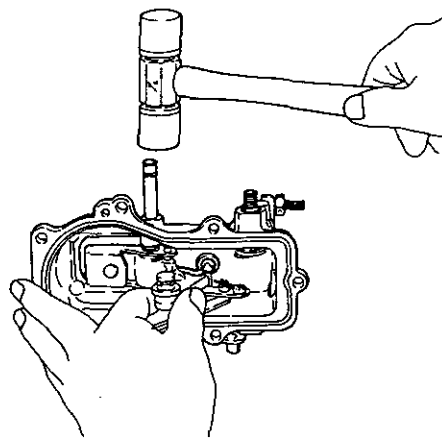
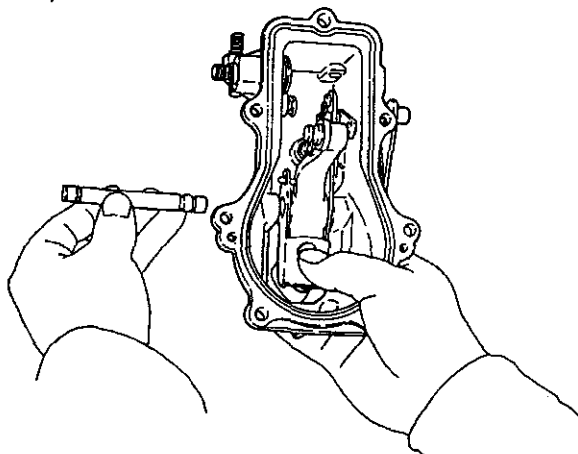

\*2. Make sure to insert the governor lever shaft in the correct direction.

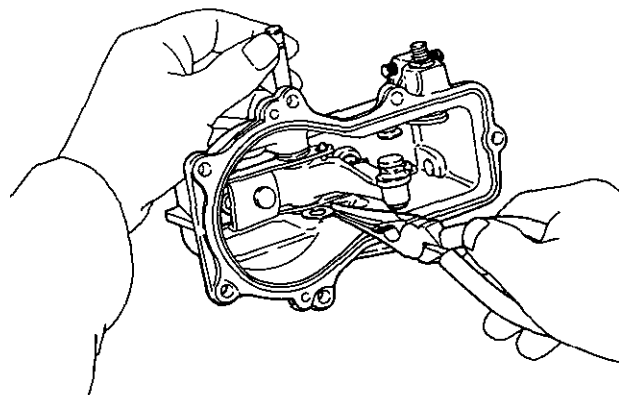

\*3. Don't forget to mount the washers on both sides of the governor lever.

(8) After you have mounted the O-ring, tap the governor lever in the opposite direction, and mount the circlip on the grooves at both ends. (for DI)

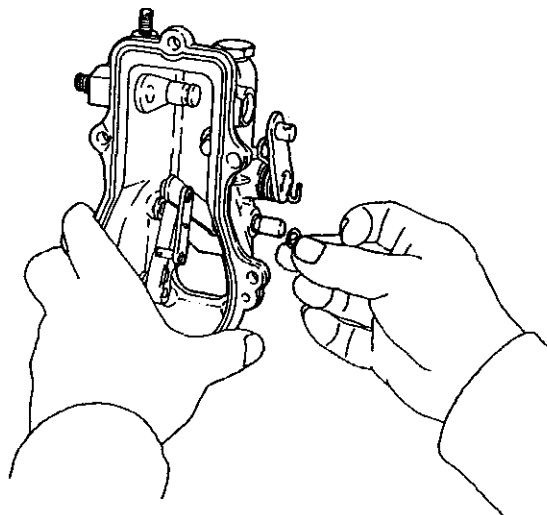

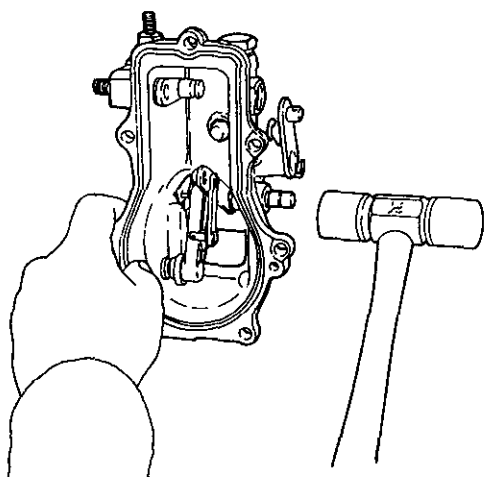

\* After mounting the governor lever assembly, make sure the governor lever assembly moves smoothly.

- (9) Fit the stop lever return spring to the end of the governor lever shaft. (DI only)

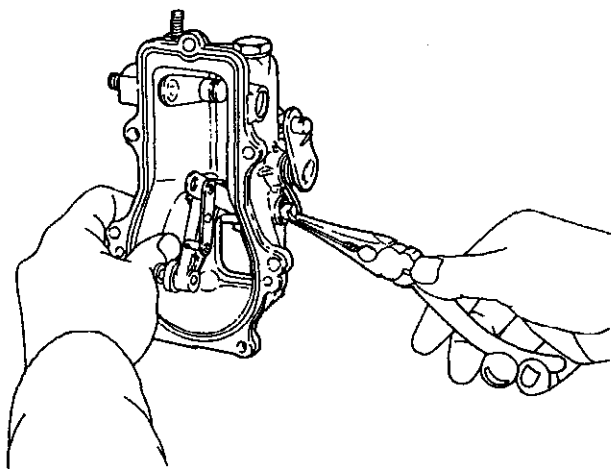

- (10) Hook the governor spring on the control lever shaft and tension lever hook with long nosed pliers.

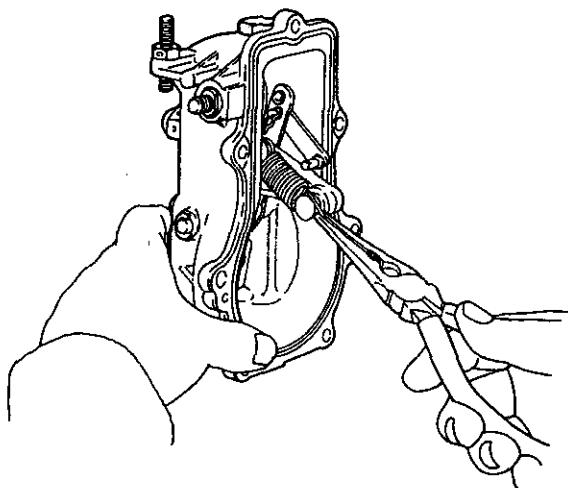

- (11) Pull the governor link as far as possible towards the governor case mounting surface, insert the governor link pin in the fuel control rack pin hole and fit the snapping on it.

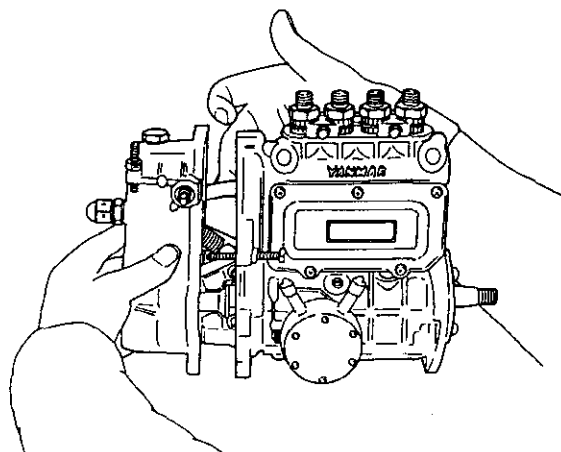

- (12) Mount the governor case to the fuel injection pump while lightly tapping it with a wooden hammer, and tighten the tightening bolt.

- (13) Mount the governor case cover. On models with idle subspring, insert the adjusting spring and adjusting rod on the governor case cover adjusting bolt.

\* If the angleich spring assembly has been removed, tighten the nut temporarily. The nut should be securely tightened after adjustment.

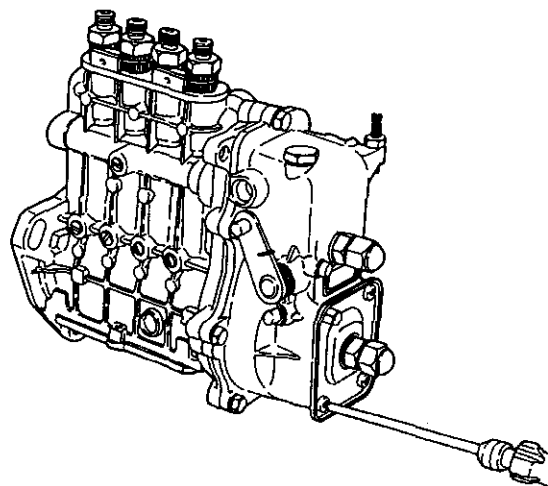

### 13. Governor

---

(14) Insert the control lever in the control lever shaft and tighten the nut.

\* *Move the control lever back and forth to make sure that the entire link moves smoothly.*

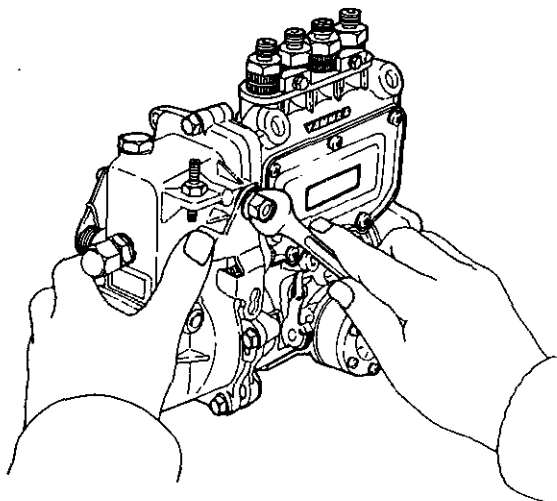



# 14. Turbocharger

## 14-1. Specifications

Applicable engine model (application)	3TNE84T (CL, VM)	3TNE84T (CH, VH)
	4TNE84T (CL)	4TNE84T (VM, CH, VH)
Turbocharger model	RHB31	RHB51
Turbocharger specification	Standard (w/waste gate)	
Turbine type	Radial flow	
Blower (compressor) type	Centrifugal	
Lubrication method	External lubrication	
Max. continuous allowable rpm	250,000	180,000
Max. continuous allowable gas inlet temperature	750°C	
Dry weight	2.4 kg	4.2 kg

Note) VM and VH applications are provided with the waste gate.

## 14-2. Construction

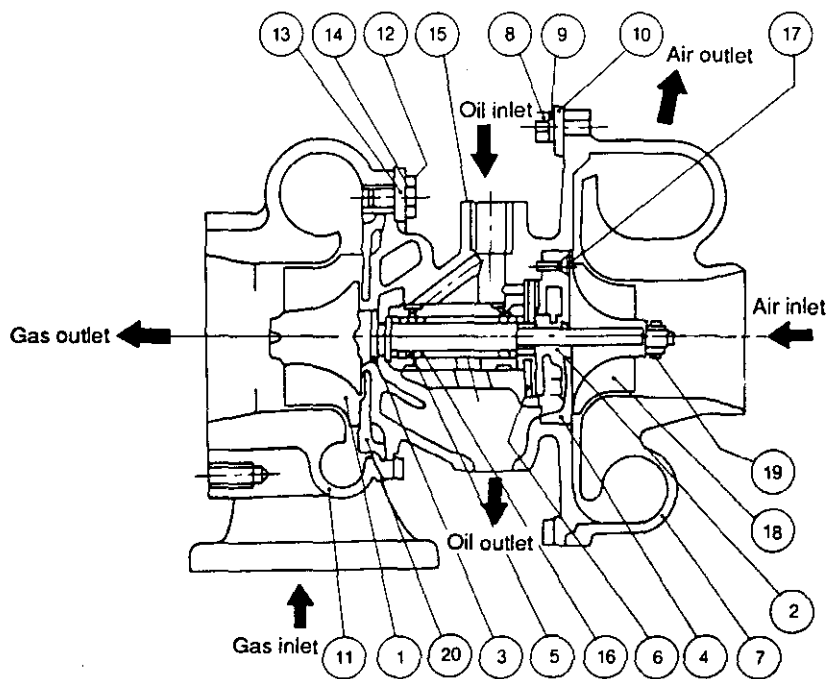

No.	Part name
1	Turbine shaft
2	Oil thrower
3	Turbine side seal ring
4	Seal plate
5	Journal bearing
6	Thrust bearing
7	Compressor housing
8	M5 hexagon bolt
9	M5 spring washer
10	Compressor side clamp
11	Turbine housing
12	M6 hexagon bolt
13	Turbine side clamp
14	Lock washer
15	Bearing housing
16	Retaining ring
17	M3 countersunk flat head screw
18	Compressor wheel
19	Shaft end nut
20	Heat protector

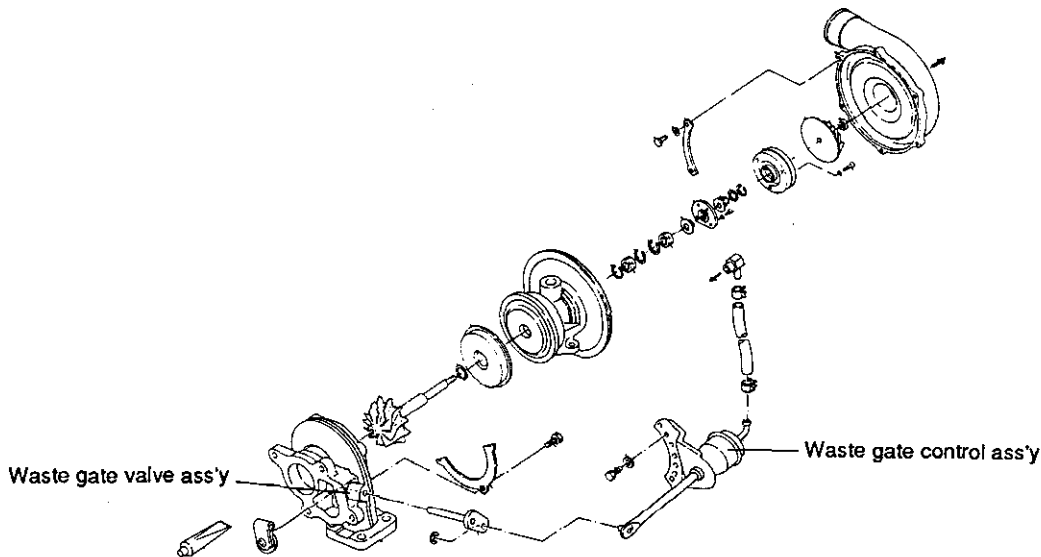

(Exploded view of turbocharger w/waste gate)

[Note]

A waste gate valve is adopted in the turbocharger for VM or VH (variable speed) application.

\* The waste gate valve is a turbocharger speed control system to maintain the intake air pressure at a constant level by bypassing a part of the exhaust gas for driving the turbocharger by using the intake air pressure on the compressor side. It consists of a control ass'y separated from the turbocharger and a valve ass'y built in the turbine housing.

(1) Turbine

The exhaust gas from the engine is accelerated at the nozzle portion in the turbine housing and blown onto the turbine impeller to rotate the turbine shaft. This is called the turbine. A seal ring and heat insulating plate are installed to prevent the bearing from being adversely influenced by the gas.

2. Radial (journal bearing)

A floating journal bearing is adopted. Because the bearing moves with the turbine shaft as oil films are formed both inside and outside of the bearing, the bearing sliding speed is slower than the turbine shaft speed as compared with the ordinary fixed type bearing. The dynamic stability is improved as a result.

(2) Compressor

The compressor wheel installed on the turbine shaft is rotated with the shaft to suck and compress air for feeding into the intake manifold. This is called the blower or compressor.

3. Compressor side sealing mechanism

To prevent the intake air and oil from leaking, a seal ring and a seal plate is provided to form a double wall structure on the rear side of the compressor wheel.

(3) Bearing

1. Thrust bearing

As the turbine shaft is constantly applied with a thrust force, this bearing prevents the shaft from being moved by the thrust force.

### 14-3. Waste Gate Valve Adjusting Method

Since turbochargers for VM and VH applications are provided the waste gate valve each, adjustment of the waste gate valve opening pressure and lift is indispensable at the time of overhaul or inner parts replacement. Omission of this adjustment will adversely affect the engine performance.

[Note] If the adjustment is impossible, leave off inner parts replacement but replace the whole turbocharger ass'y.

#### (1) Checking the waste gate valve pressure and lift characteristics

##### 1. Equipment

Prepare the equipment shown in the figure below.

##### 2. Measuring instruments and devices

Dial gage	Capable of measuring 0 to 10 mm (A flat head type is desirable.)
Manometer	Either mercury column or electric type (capable of measuring 0 to 1500 mmHg)
Pressure regulating valve	Capable of gradually adjusting in a range between 0 and 2 kg/cm <sup>2</sup> (for controlling the pressure applied to the waste gate actuator)
Pressure reducing valve	Used for suppressing the air supply pressure at 5 kg/cm <sup>2</sup> or less
Pressure gage	Bourdon tube pressure gage (0 to 10 kg/cm <sup>2</sup> )

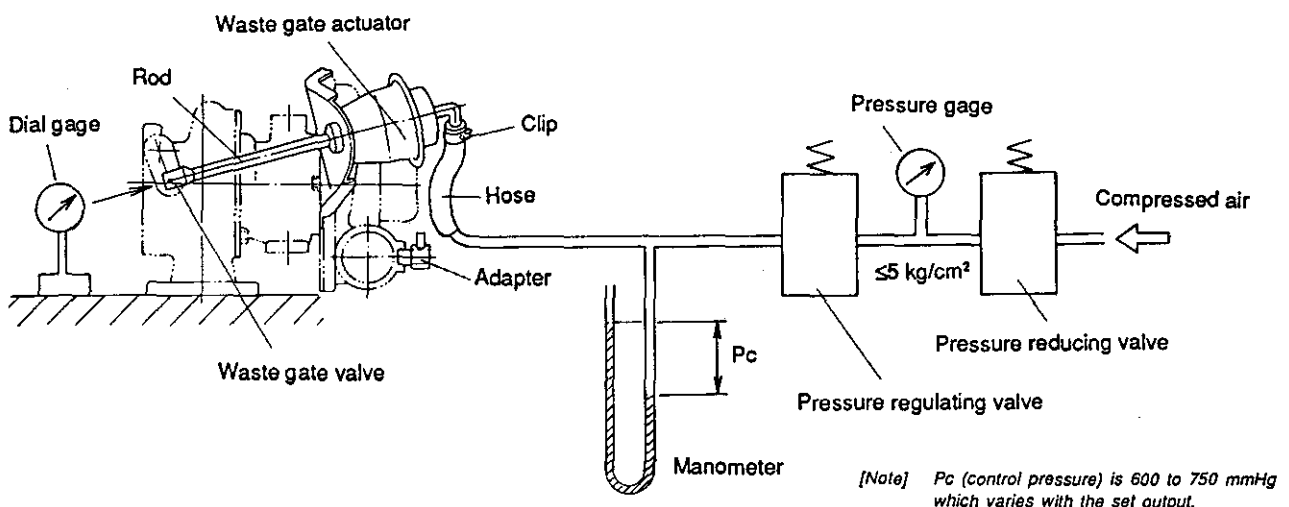

3. Check method

- ① Set the manometer control pressure ( $P_c$ ) applied to the waste gate actuator to 0 and set the dial gage to the zero point.
- ② Gradually open the pressure regulating valve and measure the  $P_c$  value when the actuator rod is operated by 2 mm.
- ③ For the hysteresis, let the rod move to 3 mm first. Then gradually close the pressure regulating valve, measure the pressure when the rod is moved to 2 mm and obtain the difference from the pressure measured in ② above.

4. Precautions

- ① Set the dial gage on the extension line of the actuator rod.
- ② The piping and joints shall completely be free from leak.
- ③ Fix the turbocharger and dial gage securely.
- ④ An electric manometer, if used, shall have sufficient precision.
- ⑤ Even when an electric manometer is used, preparation of a mercury column type manometer is recommended for calibration and daily check.
- ⑥ The speed for increasing/decreasing  $P_c$  by means of the pressure regulating valve shall be very slow near the measuring point. If the 2 mm position is exceeded, restart from the beginning.
- ⑦ Do not apply over 5 kg/cm<sup>2</sup> to the actuator.

(2) Waste gate actuator leak test

Apply 1.2 kg/cm<sup>2</sup> to the actuator and hold the state for 1 minute. The actuator is good if the pressure then is 1.1 kg/cm<sup>2</sup> or more.

## 14-4. Exploded View of Turbocharger (w/Waste Gate)

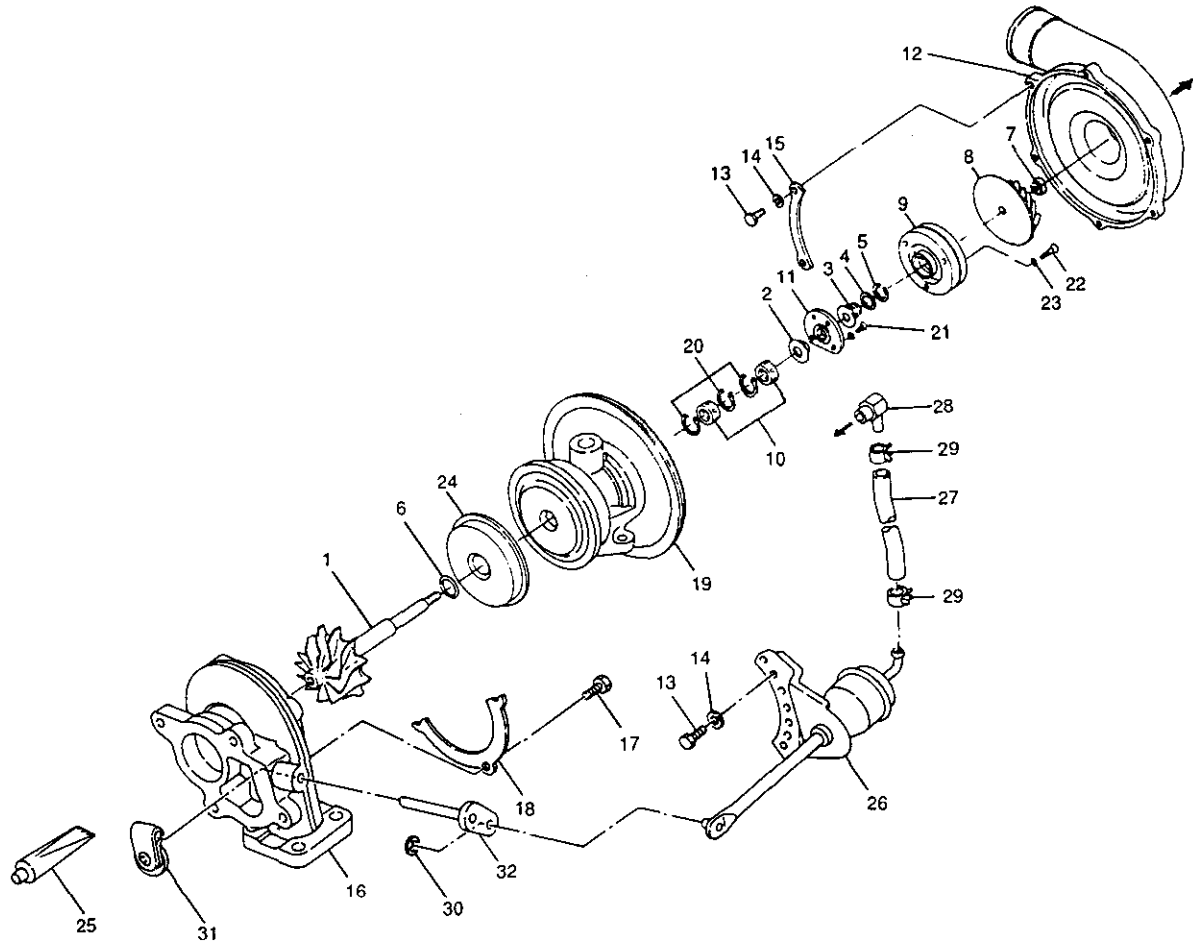

No.	Part name	No.	Part name
1	Turbine shaft	17	Bolt
2	Thrust bushing	18	Lock plate
3	Oil thrower	19	Bearing housing
4	Seal ring	20	Retaining ring
5	Seal ring	21	Screw
6	Seal ring (turbine side)	22	Screw
7	Lock nut	23	Lock washer
8	Impeller	24	Heat protector
9	Seal plate	25	Liquid gasket
10	Journal bearing	26	Waste gate actuator
11	Thrust bearing	27	Hose
12	Compressor housing	28	Adapter
13	Flanged bolt	29	Clip
14	Spring washer	30	Retaining ring
15	Clamp	31	Waste gate valve
16	Turbine housing	32	Link plate

### 14-5. Tightening Torque

Part No.	Part name	Size	Tightening torque (kg-cm)	
			RHB31	RHB51
7	Lock nut	—	9 ~ 11	18 ~ 22
13	Flanged bolt	M5	40 ~ 50	←
17	Bolt	M6	120 ~ 130	120 ~ 130
		M8		275 ~ 295
21	Screw	M3	12 ~ 14	←
22	Screw	M3	12 ~ 14	←

### 14-6. Service Standards

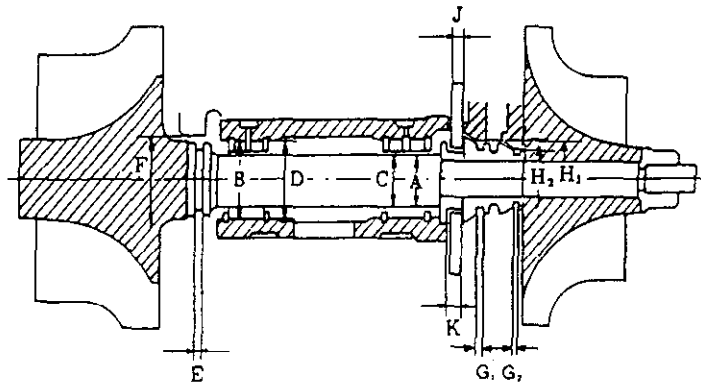

Unit: mm

		Standard dimension		Wear limit	
		RHB31	RHB51	RHB31	RHB51
Turbine shaft	Turbine shaft journal outside diameter (A)	6.257 ~ 6.263	7.99 ~ 8.00	6.25	7.98
	Turbine shaft seal ring groove width (E)	1.038 ~ 1.062	1.25 ~ 1.28	1.07	1.29
	Compressor side seal ring groove width (G <sub>1</sub> )	1.02 ~ 1.03	1.22 ~ 1.23	1.04	1.31
	Compressor side seal ring groove width (G <sub>2</sub> )	0.82 ~ 0.83	1.02 ~ 1.03	0.84	1.11
	Turbine shaft runout	0.002	0.002	0.005	0.011
Bearing	Journal bearing inside diameter (C)	6.275 ~ 6.285	8.01 ~ 8.03	6.29	8.04
	Journal bearing outside diameter (D)	9.940 ~ 9.946	12.32 ~ 12.33	9.93	12.31
	Bearing housing inside diameter (B)	9.995 ~ 10.005	12.40 ~ 12.41	10.01	12.42
Thrust bearing	Thrust bearing width (J)	3.59 ~ 3.61	3.99 ~ 4.01	3.58	3.98
	Thrust bushing groove dimension (K)	3.632 ~ 3.642	4.04 ~ 4.05	3.65	4.07
Seal ring fixing area	Turbine side (bearing housing) (F)	11.00 ~ 11.018	15.00 ~ 15.02	11.03	15.05
	Compressor side (seal ring) (H <sub>1</sub> )	9.987 ~ 10.025	12.40 ~ 12.42	10.04	12.45
	Compressor side (seal ring) (H <sub>2</sub> )	7.968 ~ 8.00	10.00 ~ 10.02	8.01	10.05
Rotor play in axial direction		0.022 ~ 0.053	0.03 ~ 0.06	0.07	0.09
Rotor play in radial direction		0.061 ~ 0.093	0.08 ~ 0.13	0.12	0.17

# 15. Service Information for CARB ULG regulation

## Introduction

This chapter describes only the items designated as special specifications for servicing the TNE engine under 25 HP that complies with CARB ULG regulation (Regulation for small Utility engines and Lawn & Garden from California Air Resource Board, effects to the engines manufactured on Jan. 1st 1995 and later).

## 15-1. Emission control label

### 15-1-1. Content of the label

Size and contents of the label are as shown below.

[ Example ]

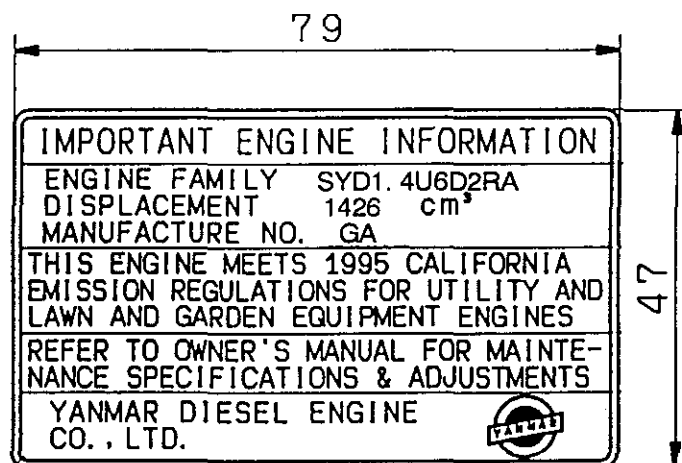

## 15-1-2. Location of the label

The locations of the label are three types A, B, and C, where the applicable engine families and engine models are as shown in the table below.

Location of the labels	No.	Engine family name for certification	Engine model in Yanmar
A	1	SYD493U6D2RA	2TN66C, 2TNE66KC
	2	SYD739U6D2RA	3TN66C, 3TNE66KC
	3	SYD784U6D2RA	3TNE68C
	4	SYD1.0U6D2RA	3TNA72C/3TNE74C 3TNE72KC
B	5	SYD1.3U6D2RA	3TNE78AC/3TNE82AC
	6	SYD1.4U6D2RA	3TNE82C
	7	SYD1.6U6D2RA	3TNE84C/3TNE88C
	8	SYD1.5U6D2RA	3TNE84TC
C	9	SYD1.9U6D2RA	4TNE82C
	10	SYD2.2U6D2RA	4TNE84C/4TNE88C



Location: A

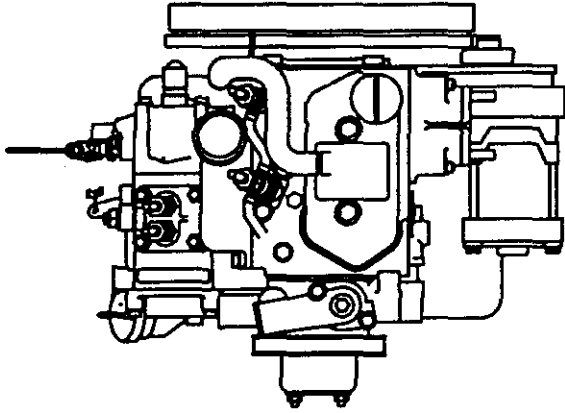

EMISSION CONTROL LABEL

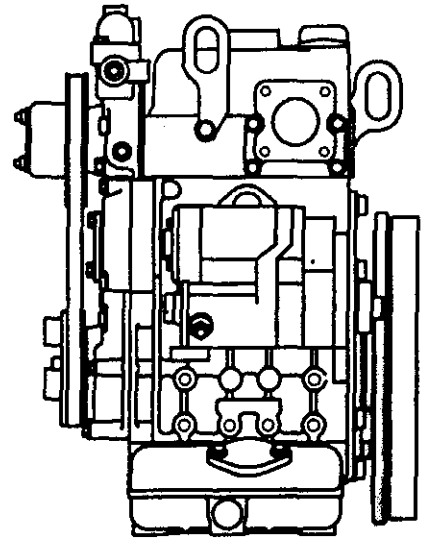
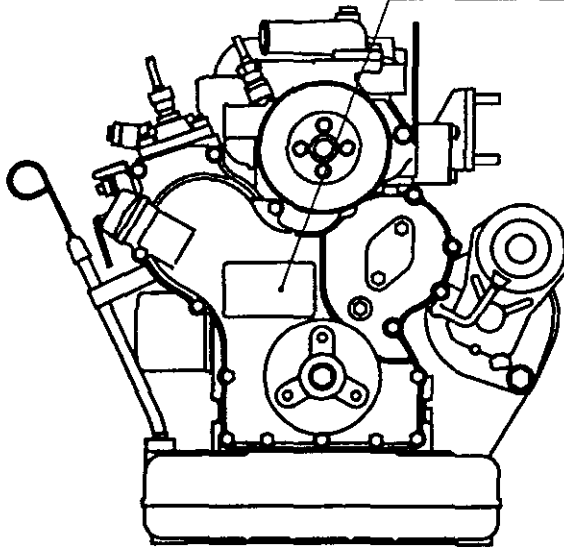

**Location: B**

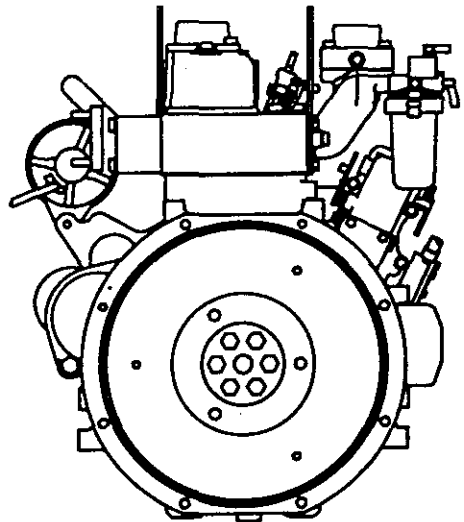
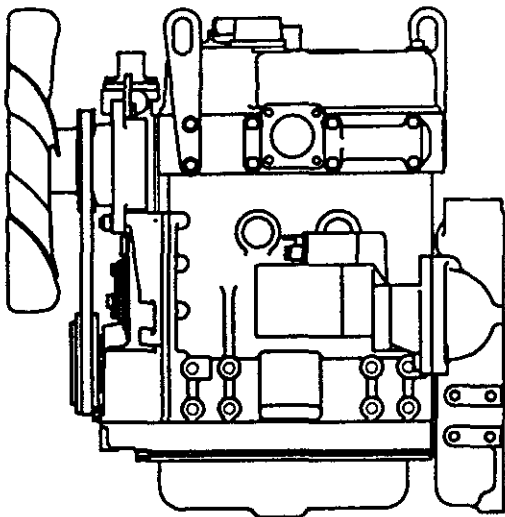
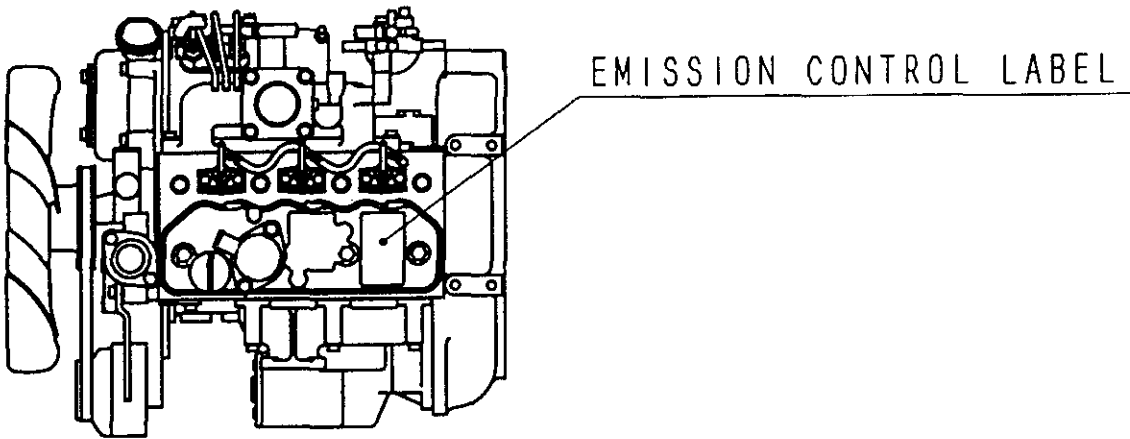

Location: C

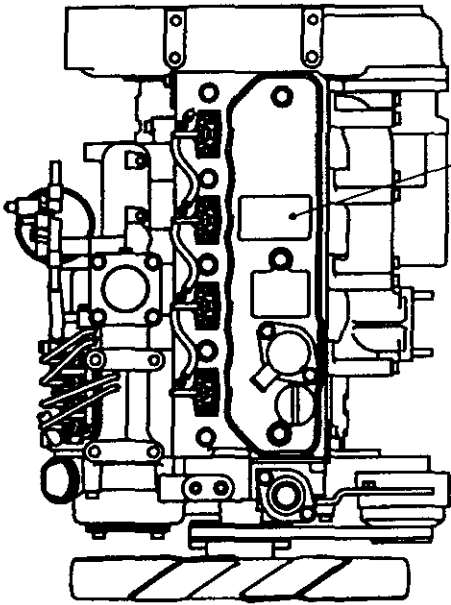

EMISSION CONTROL LABEL

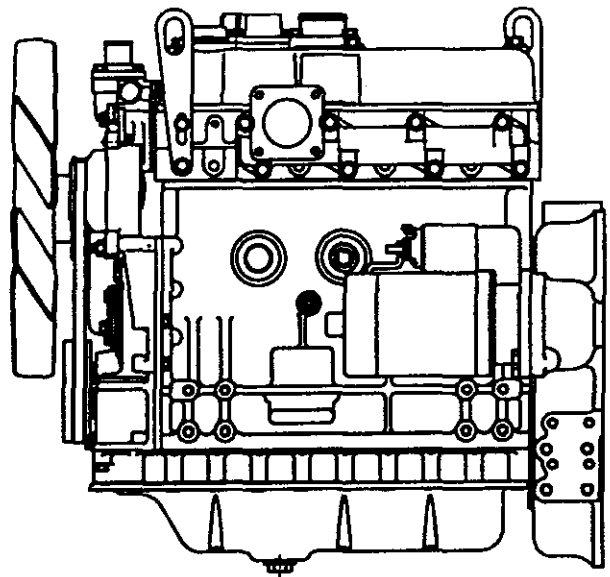
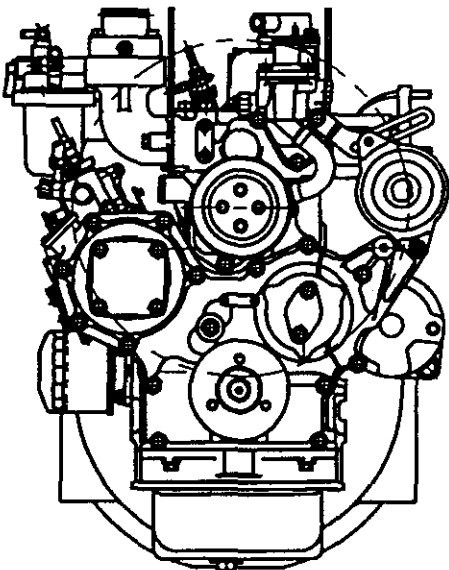

## 15-2 Limiting the high idle and low idle adjustment screw

### 15-2.1 High idle speed

- (1) First warm up the engine. Then, gradually increase the engine speed up to the high idle speed (Refer to Chapter 1, Specifications and Performance).
- (2) If the present high idle speed differ from the specified one, adjust the high idle speed using the high idle adjustment screw.
- (3) After locking the adjustment screw with the lock nut by using the special tool, insert the plug firmly to prevent re-adjustment and oil leakage.

*\*1: Do not adjust the high idle adjustment screw unless necessary.*

*\*2: The illustration shows the partial perspective view of the governor for the direct injection system.*

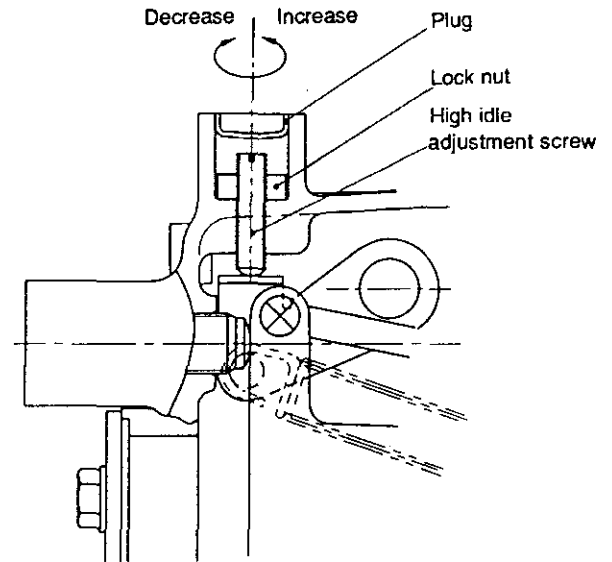

### 15-2.2 Low idle speed

After warming up the engine, set the low idling speed (Refer to Chapter 1, Specifications and Performance) by turning the low idle adjustment screw.

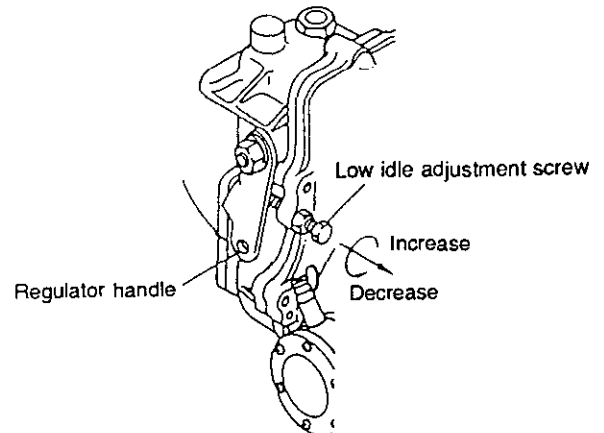

## 15-3 Limiting the fuel volume limiter screw

- 1) After limiting the fuel volume, lock the fuel volume limiter screw with the lock nut by using the special tool.
- 2) Then, insert the plug firmly to prevent re-adjustment and oil leakage.

**\*: Do not adjust the fuel volume limiter screw unless necessary.**

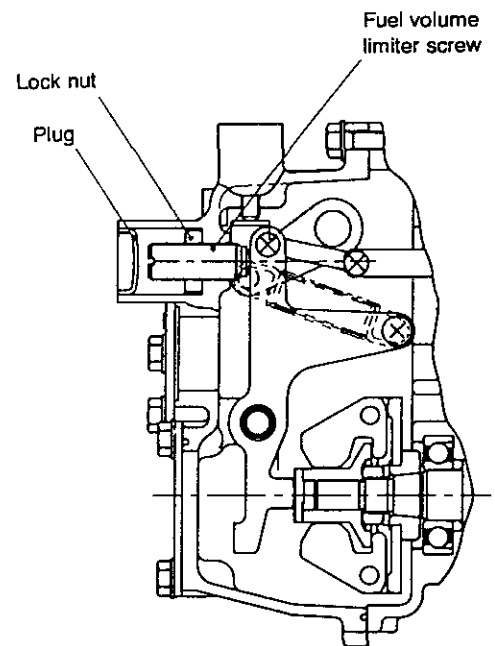

# Attached Drawing 1.

## Exploded Views of Engine Components

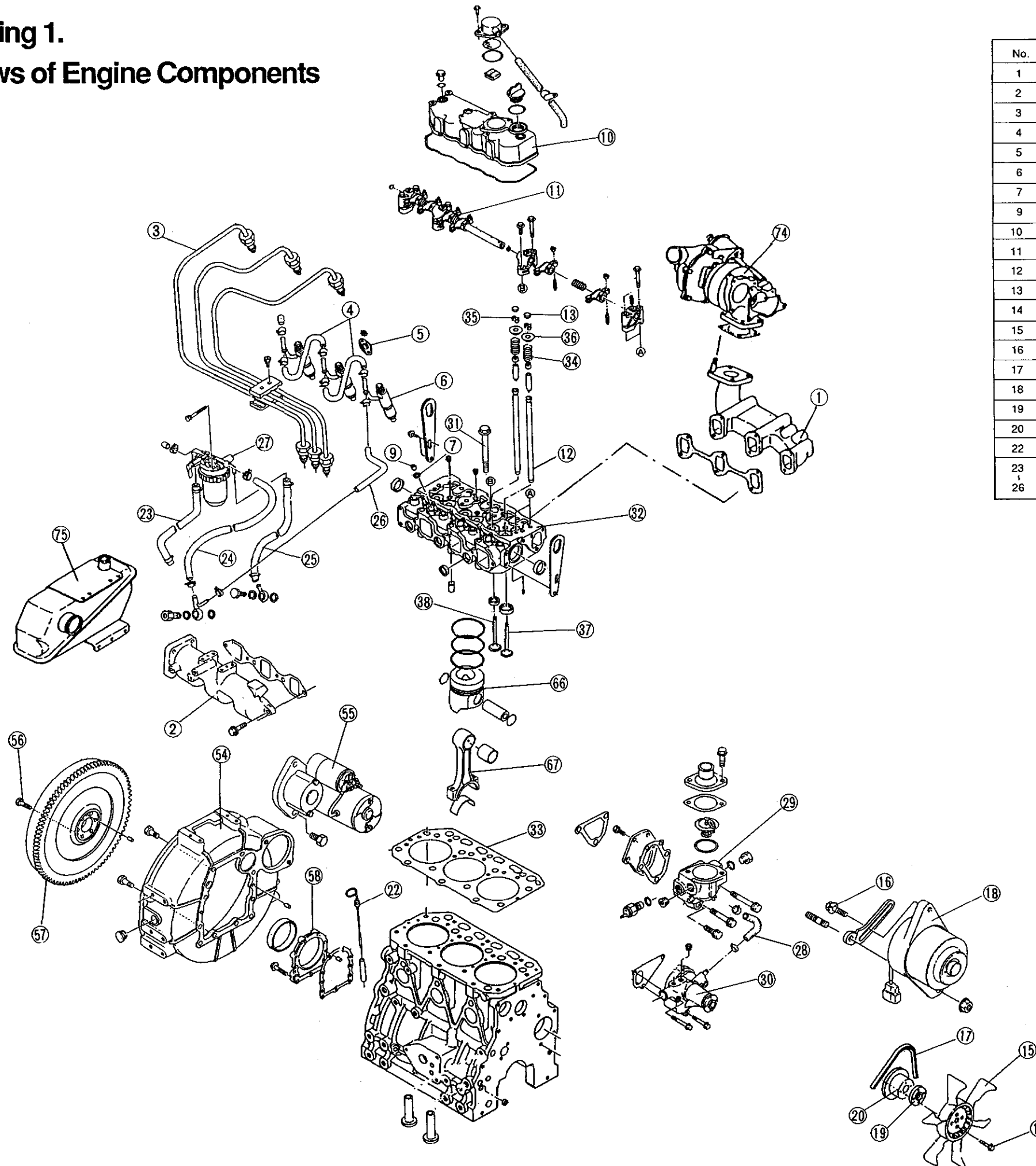

No.	Engine Component	No.	Engine Component
1	Exhaust manifold	27	Fuel filter
2	Intake manifold	28	Cooling water pipe
3	High-pressure fuel pipe	29	Thermostat assembly
4	Fuel return pipe	30	Cooling water pump
5	Fuel injection nozzle retainer	31	Cylinder head tightening bolt
6	Fuel injection nozzle	32	Cylinder head assembly
7	Nozzle seat	33	Cylinder head gasket
9	Nozzle protector	34	Valve spring
10	Bonnet assembly	35	Valve cotter
11	Valve rocker arm shaft assembly	36	Valve retainer
12	Push rod	37	Intake valve
13	Valve cap	38	Exhaust valve
14	Fan mounting bolt	54	Flywheel housing
15	Fan	55	Starting motor
16	Adjusting bolt	56	Flywheel mounting bolt
17	V-belt	57	Flywheel
18	Alternator	58	Oil seal case
19	Spacer	66	Piston
20	V-pulley	67	Connecting rod
22	Dipstick	74	Turbocharger (3TNE84T, 4TNE84T)
23 26	Fuel return pipe	75	Surge tank (3TNE84T)

# Attached Drawing 2. Exploded Views of Engine Components

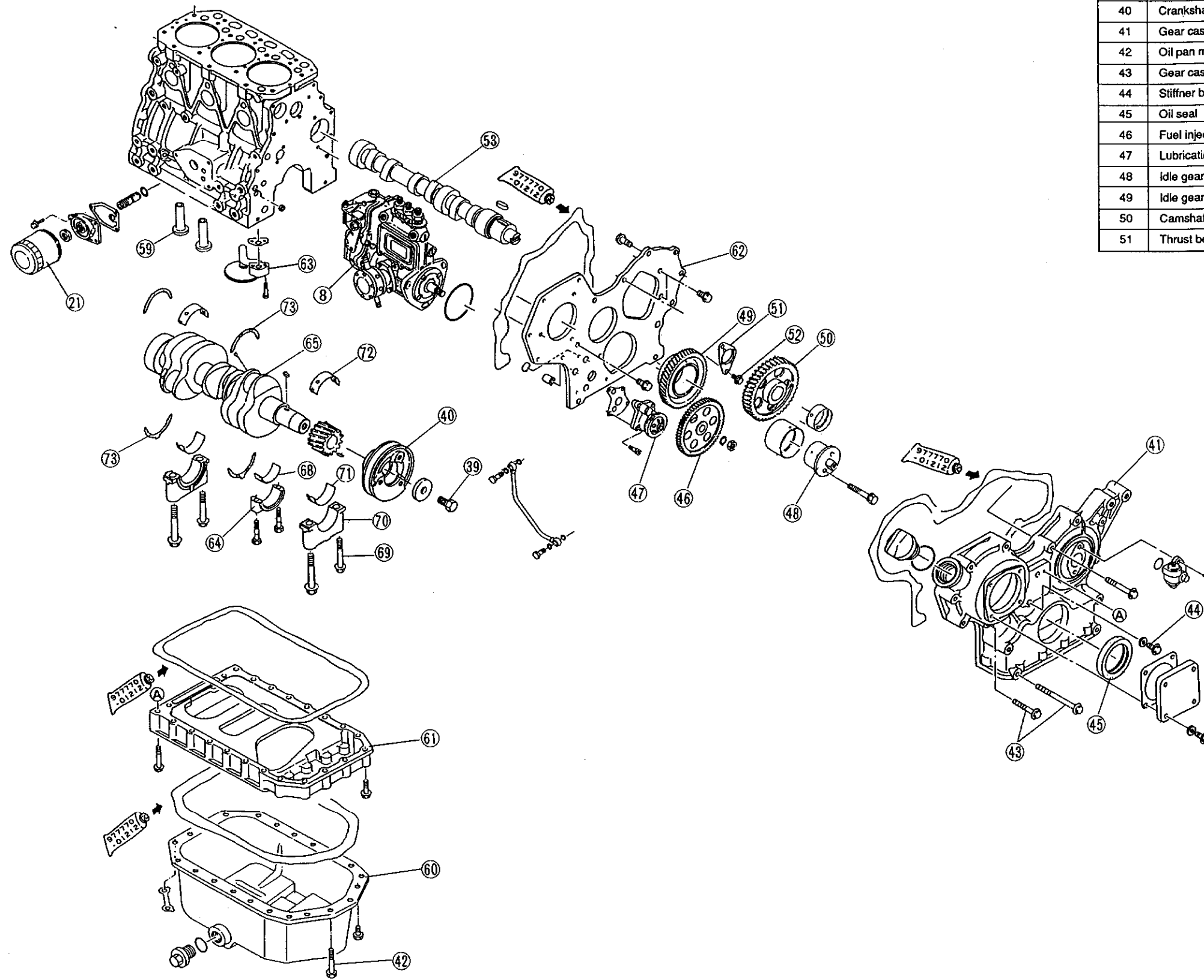

No.	Engine Component	No.	Engine Component
8	Fuel injection pump	52	Mounting bolt
21	Oil filter assembly	53	Camshaft assembly
39	V-pulley clamping bolt	59	Tappet
40	Crankshaft V-pulley	60	Oil pan
41	Gear case	61	Spacer
42	Oil pan mounting bolt	62	Gear case flange
43	Gear case mounting bolt	63	Lubricating oil strainer
44	Stiffner bolt	64	Crank pin side cap
45	Oil seal	65	Crankshaft
46	Fuel injection pump drive gear	68	Crank pin metal
47	Lubricating oil pump	69	Main bearing cap bolt
48	Idle gear shaft	70	Main bearing cap
49	Idle gear	71	Lower main bearing metal
50	Camshaft gear	72	Upper main bearing metal
51	Thrust bearing	73	Thrust metal

**YANMAR DIESEL AMERICA CORP.**

951 CORPORATE GROVE DRIVE BUFFALO GROVE. IL 60089-4508 U.S.A.  
TEL: 1-847-541-1900  
FAX: 1-847-541-2161

**YANMAR EUROPE B.V.**

BRUGPLEIN 11, 1332 BS ALMERE-DE VAART. THE NETHERLANDS P.O. BOX 30112. 1303 AC ALMERE  
TEL : 31-36-5324924  
FAX : 31-36-5324916  
TELEX : 70732 YMR A NL

**YANMAR ASIA (SINGAPORE) CORPORATION PTE LTD.**

4 TUAS LANE. SINGAPORE 2263  
TEL : 65-861-5077  
FAX : 65-861-1508  
TELEX : RS 35854 YANMAR

**YANMAR DIESEL ENGINE CO., LTD.**

OVERSEAS OPERATIONS DIVISION  
1-1, 2-CHOME, YAESU, CHUO-KU, TOKYO 104, JAPAN  
TEL : 81-3-3275-4933  
FAX : 81-3-3275-4967  
TELEX : 222-4733 YANMAR J



**YANMAR DIESEL ENGINE CO., LTD.**

**HEAD OFFICE**

QUALITY ADMINISTRATION DIV.  
1-32, CHAYAMACHI, KITA-KU, OSAKA 530. JAPAN  
TEL : 81-6-376-6238  
FAX : 81-6-373-1124  
TELEX : 52369810 YANMARJ